

A

B

C

D

E

F

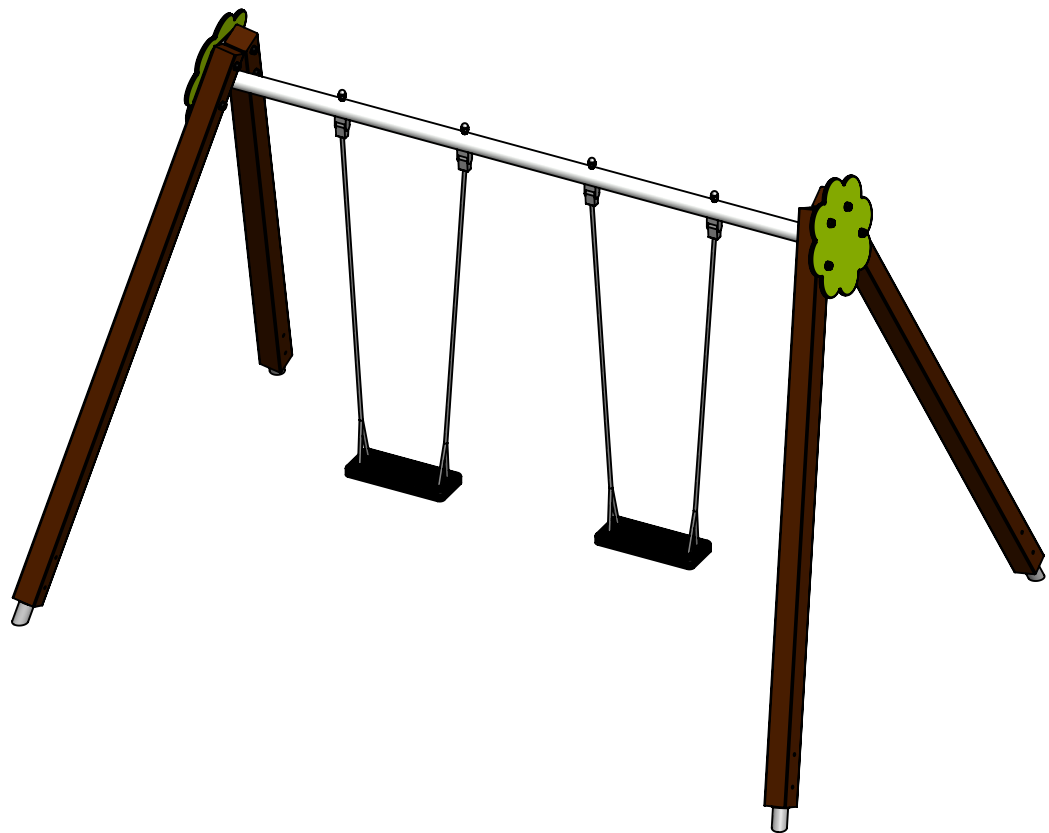

UNLESS OTHERWISE SPECIFIED:  
 DIMENSIONS ARE IN MILLIMETERS  
 WEIGHT ARE IN KILOGRAMM

PART NUMBER / DWG NO.:

K002-1

	NAME	SIGNATURE	DATE	REVISION
DRAWN	M.Rebase		05.08.2025	
APPV'D				

DESCRIPTION:

Swing BELL-FLOWER 2 places



Tiptiptap<sup>ÖÜ</sup>

MATERIAL:

A4

WEIGHT:

SCALE: 1:30

SHEET 1 OF 12

# safety area

A

B

C

D

E

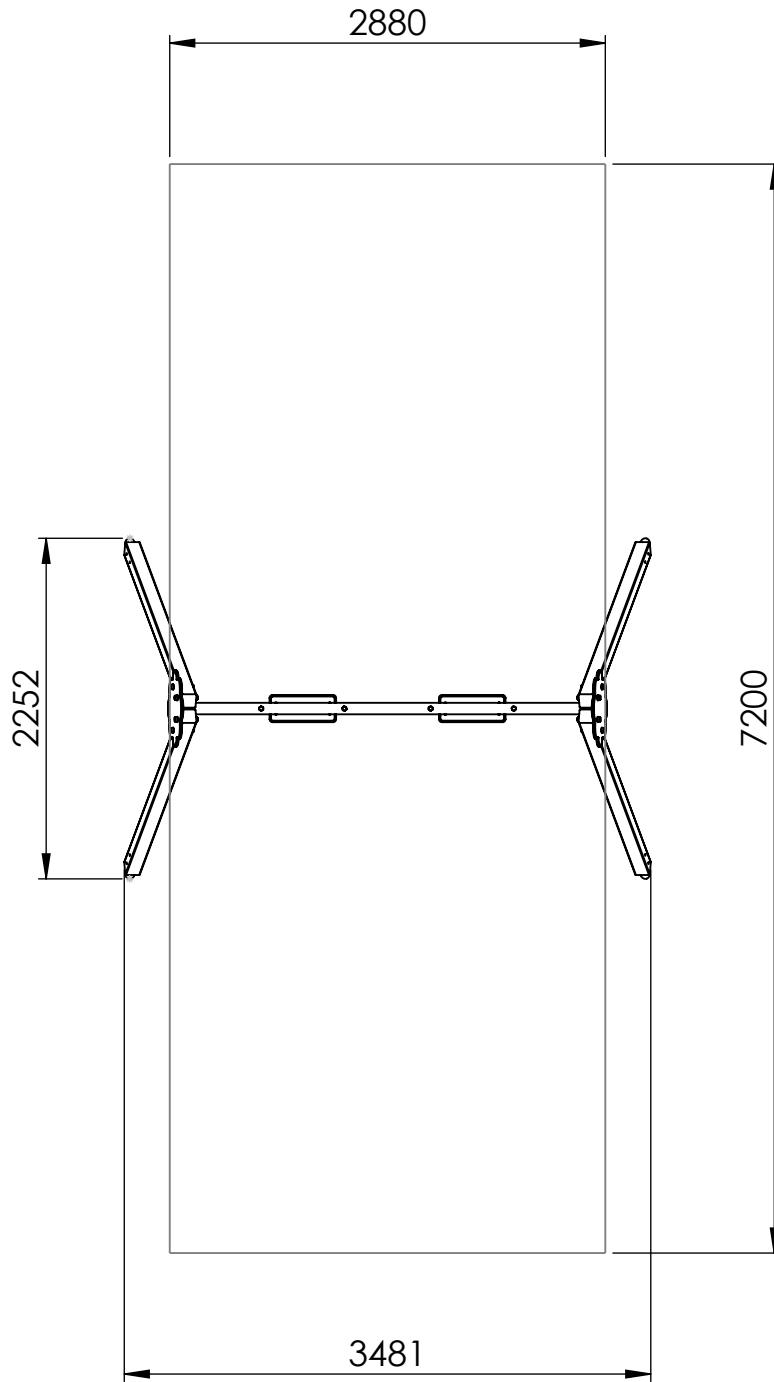

UNLESS OTHERWISE SPECIFIED:  
 DIMENSIONS ARE IN MILLIMETERS  
 WEIGHT ARE IN KILOGRAMM

PART NUMBER / DWG NO.:

K002-1

	NAME	SIGNATURE	DATE	REVISION
DRAWN	M.Rebase		05.08.2025	
APPV'D				

DESCRIPTION:

Swing BELL-FLOWER 2 places

F



**Tiptiptap** <sup>ÖÜ</sup>

MATERIAL:

A4

WEIGHT:

SCALE: 1:50

SHEET 2 OF 12

# foundation

A

B

C

D

E

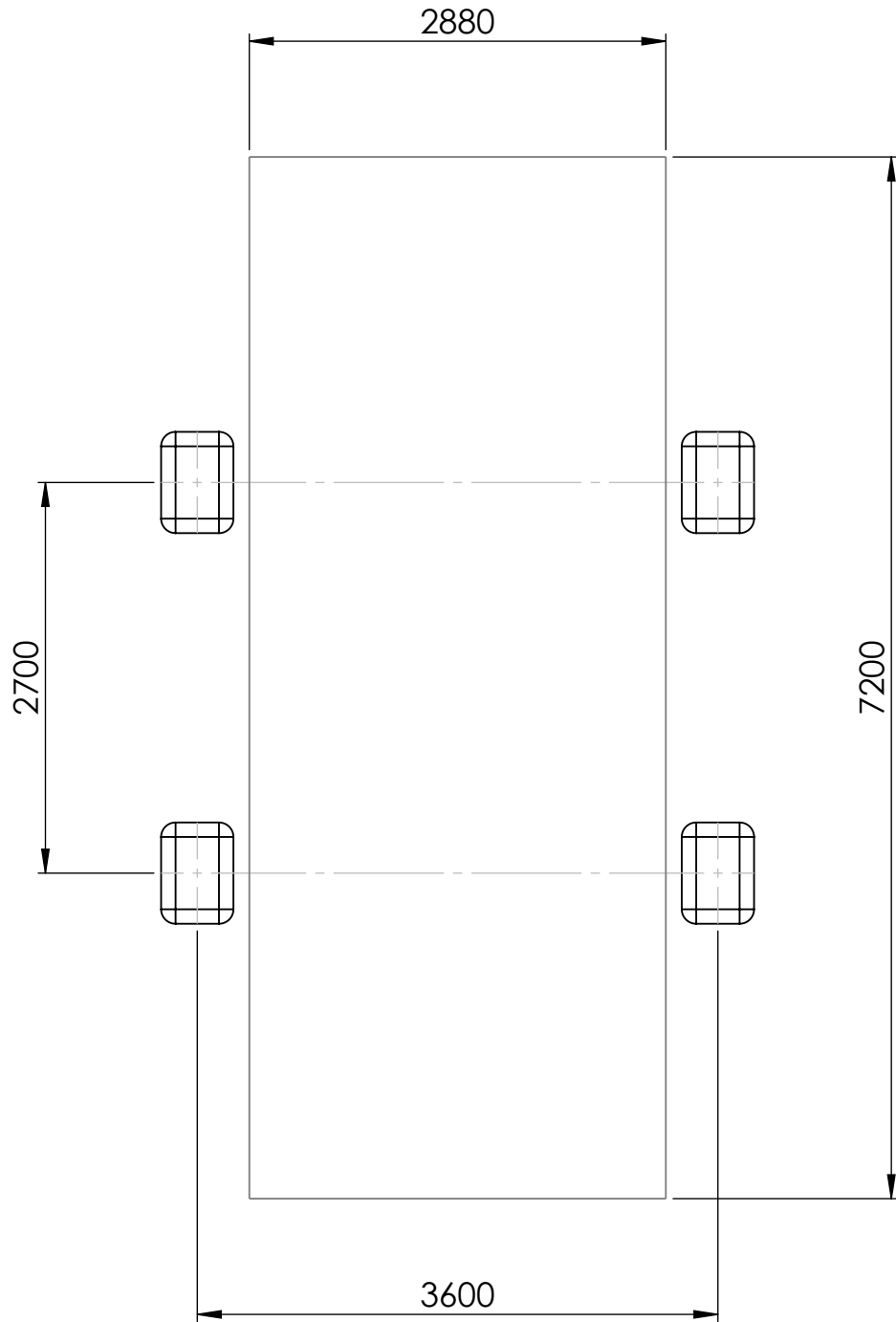

UNLESS OTHERWISE SPECIFIED:  
 DIMENSIONS ARE IN MILLIMETERS  
 WEIGHT ARE IN KILOGRAMM

PART NUMBER / DWG NO.: **K002-1**

	NAME	SIGNATURE	DATE	REVISION
DRAWN	M.Rebase		05.08.2025	
APPV'D				

DESCRIPTION:  
**Swing BELL-FLOWER 2 places**



MATERIAL:		A4
WEIGHT:	SCALE: 1:50	SHEET 3 OF 12

max. free fall height 1200mm

A

B

C

D

E

F

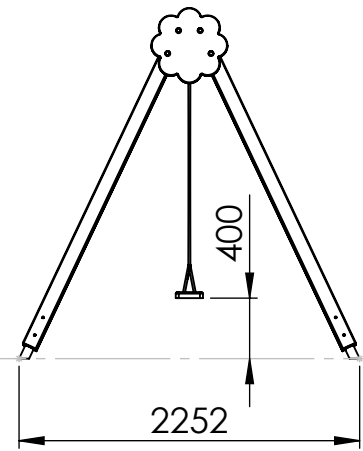
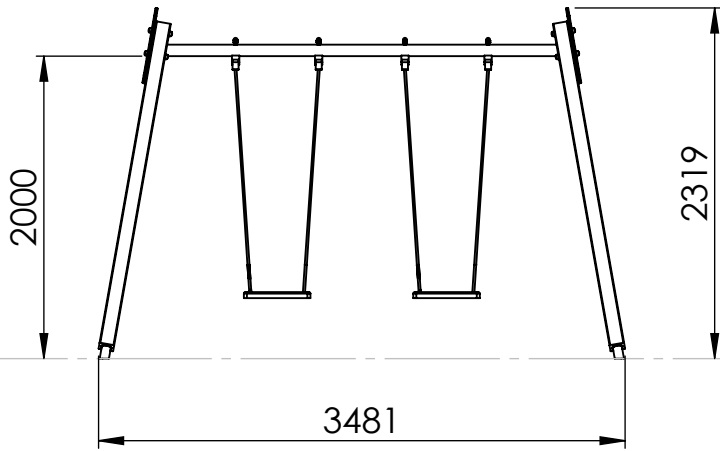

ground

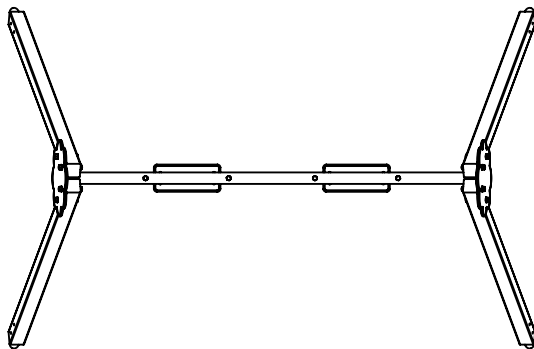

UNLESS OTHERWISE SPECIFIED:  
DIMENSIONS ARE IN MILLIMETERS  
WEIGHT ARE IN KILOGRAMM

PART NUMBER / DWG NO.:

K002-1

	NAME	SIGNATURE	DATE	REVISION
DRAWN	M.Rebase		05.08.2025	
APPV'D				

DESCRIPTION:

Swing BELL-FLOWER 2 places



Tiptiptap<sup>ÖÜ</sup>

MATERIAL:

A4

WEIGHT:

SCALE: 1:50

SHEET 4 OF 12

A

B

C

D

E

F

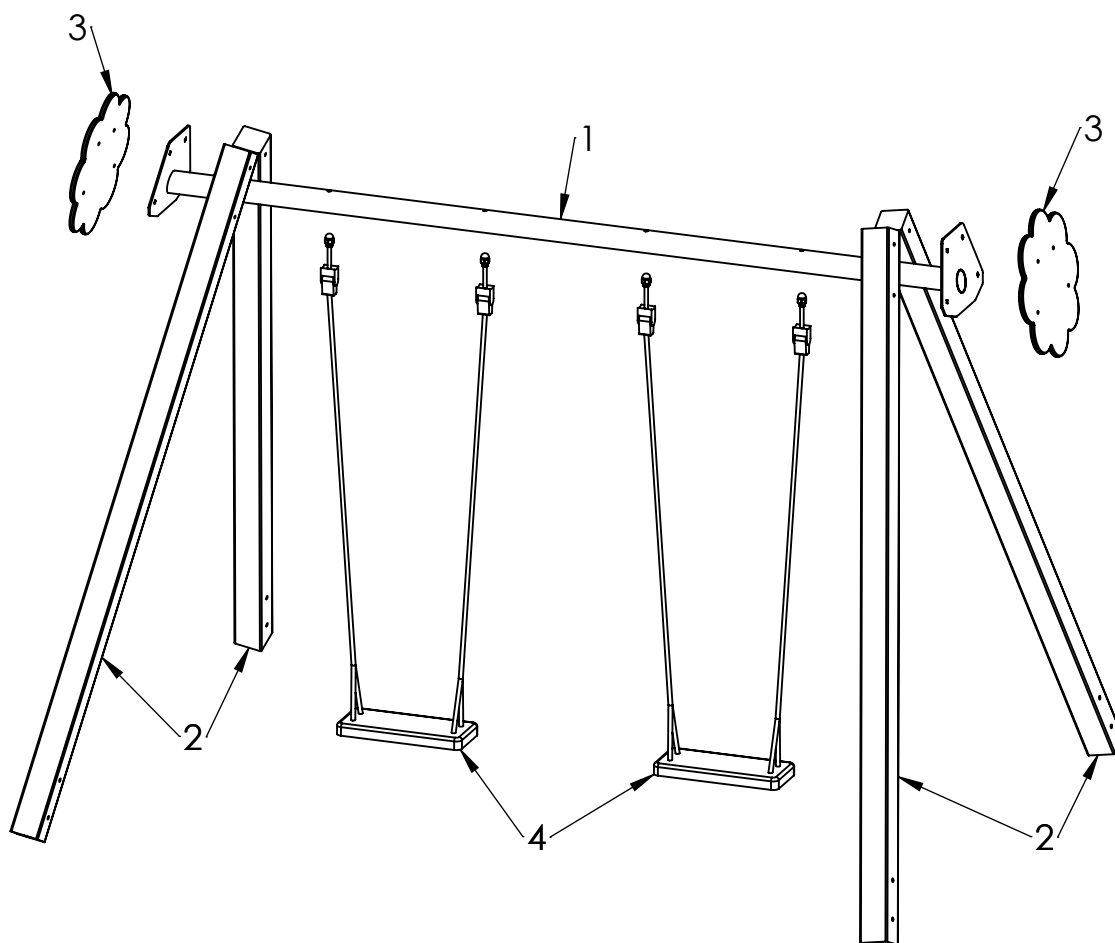

ITEM NO.	PART NUMBER	QTY.
1	beam 76x2830	1
2	post 98x98x2380	4
3	side fixture	2
4	seat complete with fitting	2

UNLESS OTHERWISE SPECIFIED:  
DIMENSIONS ARE IN MILLIMETERS  
WEIGHT ARE IN KILOGRAMM

PART NUMBER / DWG NO.:

K002-1

	NAME	SIGNATURE	DATE	REVISION
DRAWN	M.Rebase		05.08.2025	
APPV'D				

DESCRIPTION:

Swing BELL-FLOWER 2 places

MATERIAL:

A4

WEIGHT:

SCALE: 1:25

SHEET 5 OF 12



**Tiptiptap** OÜ

A

B

C

D

E

F

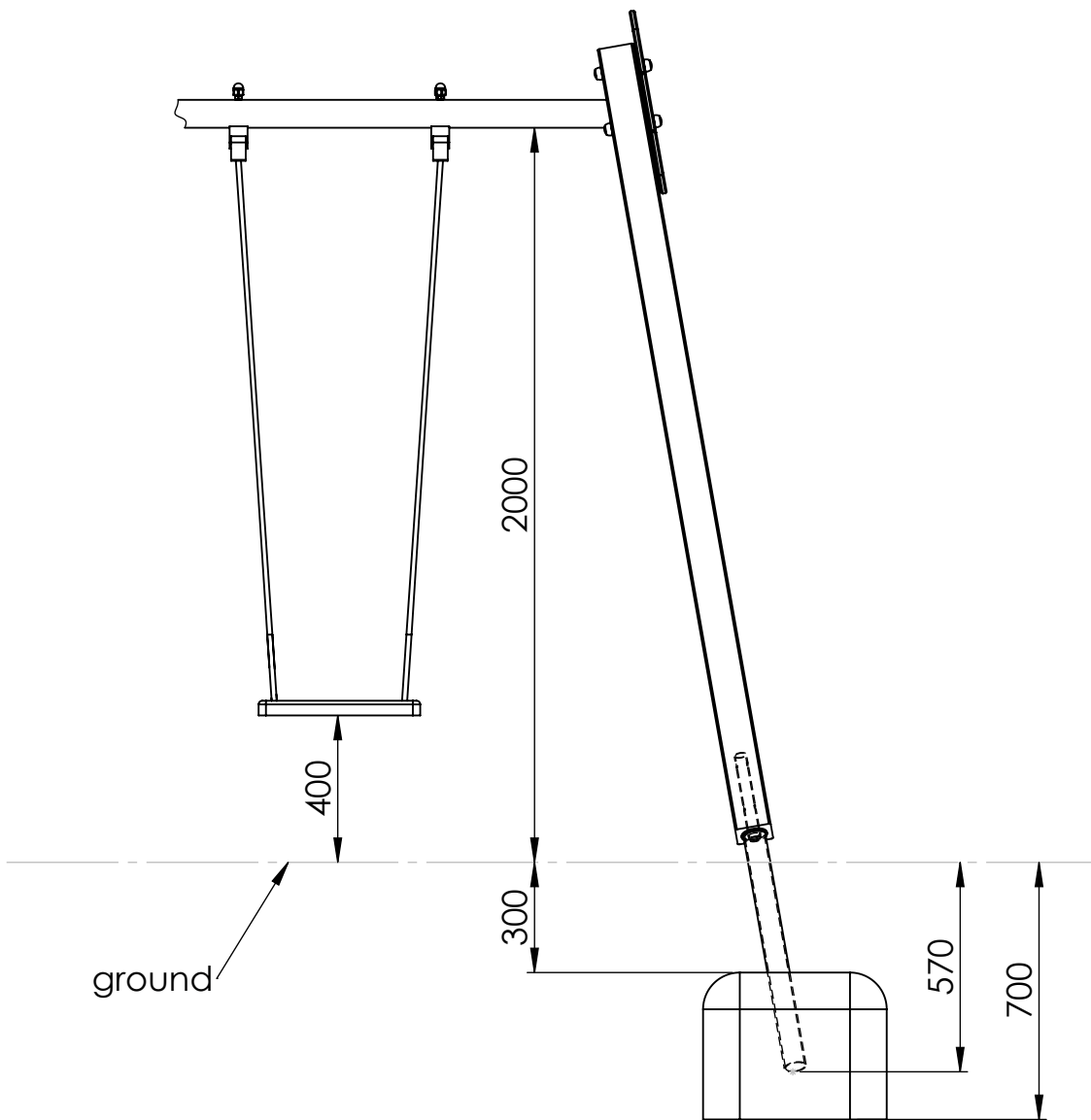

UNLESS OTHERWISE SPECIFIED:  
 DIMENSIONS ARE IN MILLIMETERS  
 WEIGHT ARE IN KILOGRAMM

PART NUMBER / DWG NO.:

K002-1

	NAME	SIGNATURE	DATE	REVISION
DRAWN	M.Rebase		05.08.2025	
APPV'D				

DESCRIPTION:

Swing BELL-FLOWER 2 places



Tiptiptap OÜ

MATERIAL:

A4

WEIGHT:

SCALE: 1:20

SHEET 6 OF 12

A

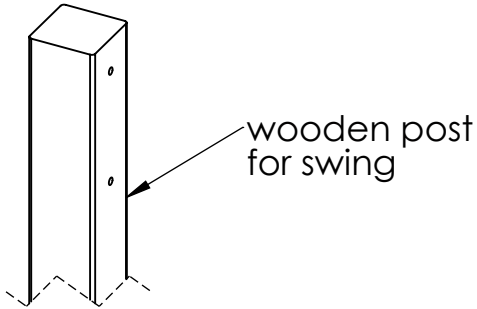

B

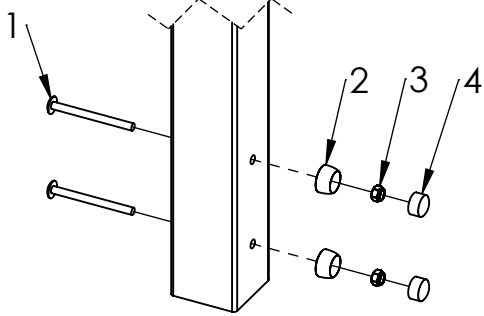

C

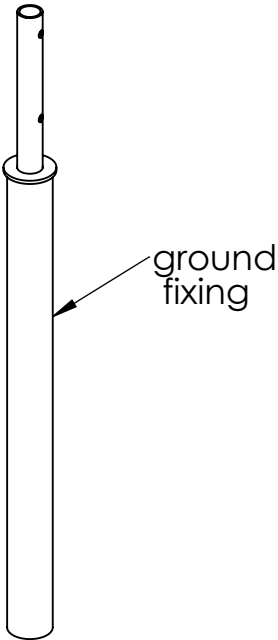

D

E

ITEM NO.	PART NUMBER
1	bolt DIN603 M10x120
2	nut cover M12
3	nut M12 DIN985
4	nut cover cap M12

F

UNLESS OTHERWISE SPECIFIED:  
DIMENSIONS ARE IN MILLIMETERS  
WEIGHT ARE IN KILOGRAMM

	NAME	SIGNATURE	DATE	REVISION
DRAWN	M.Rebase		05.08.2025	
APPV'D				

PART NUMBER / DWG NO.:  
**K002-1**

DESCRIPTION:  
**Swing BELL-FLOWER 2 places**



**Tiptap** <sup>ÖÜ</sup>

MATERIAL:		A4
WEIGHT:	SCALE: 1:10	SHEET 7 OF 12

A

B

C

D

E

F

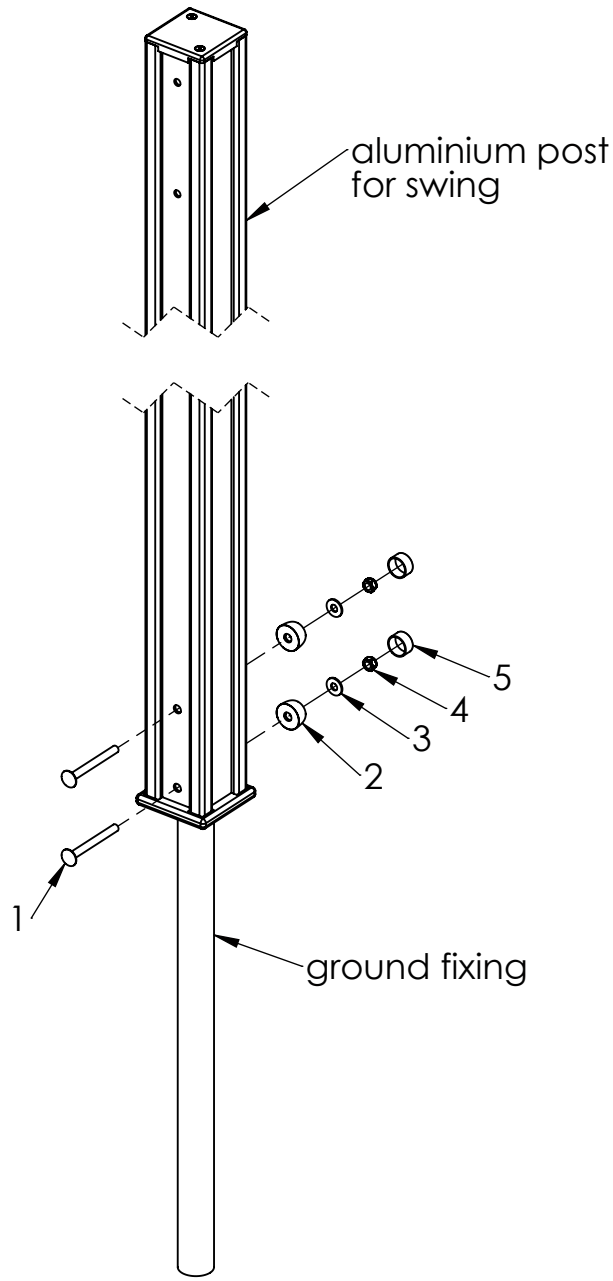

ITEM NO.	PART NUMBER
1	bolt DIN603 M10x100
2	nut cover M12
3	washer M10 DIN9054
4	nut M10 DIN985
5	nut cover cap M12

UNLESS OTHERWISE SPECIFIED:  
DIMENSIONS ARE IN MILLIMETERS  
WEIGHT ARE IN KILOGRAMM

NAME	SIGNATURE	DATE	REVISION
DRAWN M.Rebase		05.08.2025	
APPV'D			

PART NUMBER / DWG NO.:  
**K002-1**

DESCRIPTION:  
**Swing BELL-FLOWER 2 places**



**Tiptiptap** <sup>ÖÜ</sup>

MATERIAL:	A4
WEIGHT:	SCALE: 1:10 SHEET 8 OF 12

A

B

C

D

E

F

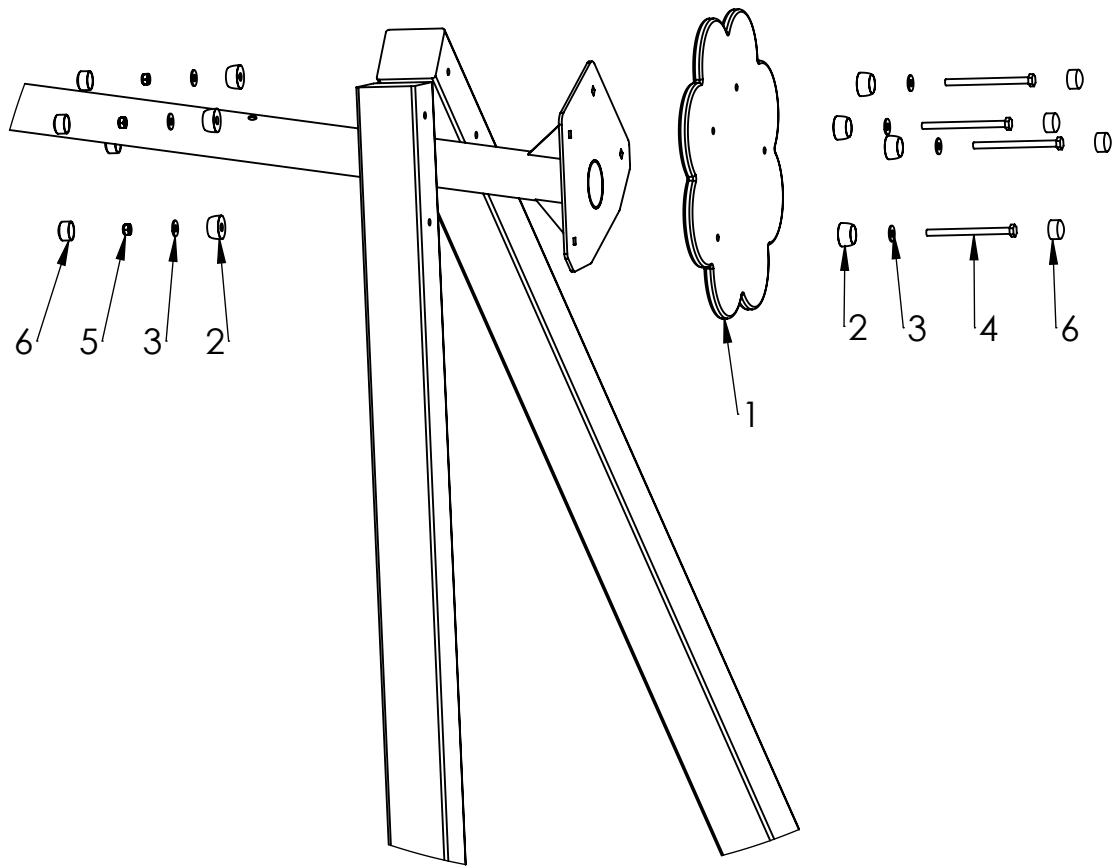

ITEM NO.	PART NUMBER
1	side fixture
2	nut cover M12
3	washer M10 DIN9054
4	for aluminium post - bolt M10x130 DIN931 for wooden post - bolt M10x140 DIN931
5	nut M10 DIN985
6	nut cover cap M12

UNLESS OTHERWISE SPECIFIED:  
DIMENSIONS ARE IN MILLIMETERS  
WEIGHT ARE IN KILOGRAMM

PART NUMBER / DWG NO.:

K002-1

	NAME	SIGNATURE	DATE	REVISION
DRAWN	M.Rebase		05.08.2025	
APPV'D				

DESCRIPTION:

Swing BELL-FLOWER 2 places

MATERIAL:

A4

WEIGHT:

SCALE: 1:100

SHEET 9 OF 12



**Tiptiptap** ÖÜ

connecting seat to beam

A

B

C

D

E

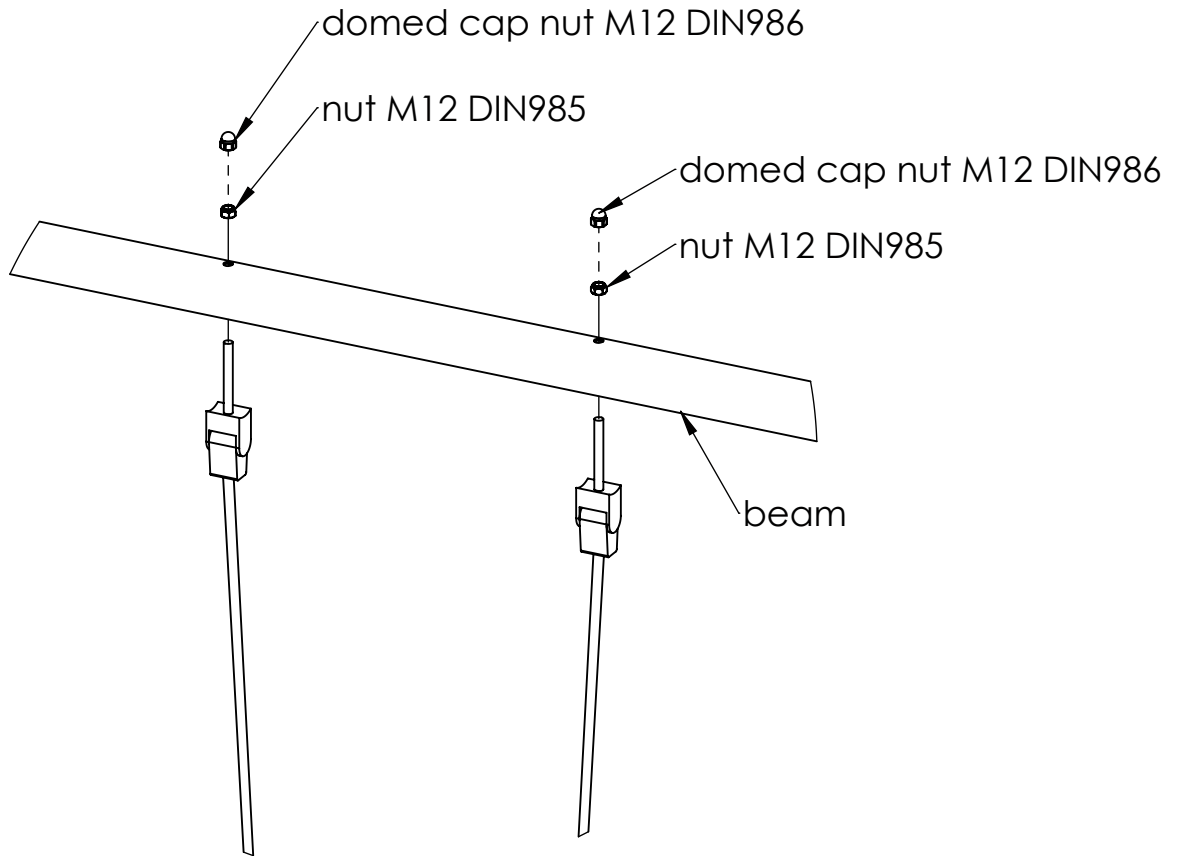

UNLESS OTHERWISE SPECIFIED:  
DIMENSIONS ARE IN MILLIMETERS  
WEIGHT ARE IN KILOGRAMM

PART NUMBER / DWG NO.:

K002-1

	NAME	SIGNATURE	DATE	REVISION
DRAWN	M.Rebase		05.08.2025	
APPV'D				

DESCRIPTION:

Swing BELL-FLOWER 2 places



**Tiptiptap** OÜ

MATERIAL:

A4

WEIGHT:

SCALE: 1:30

SHEET 10 OF 12

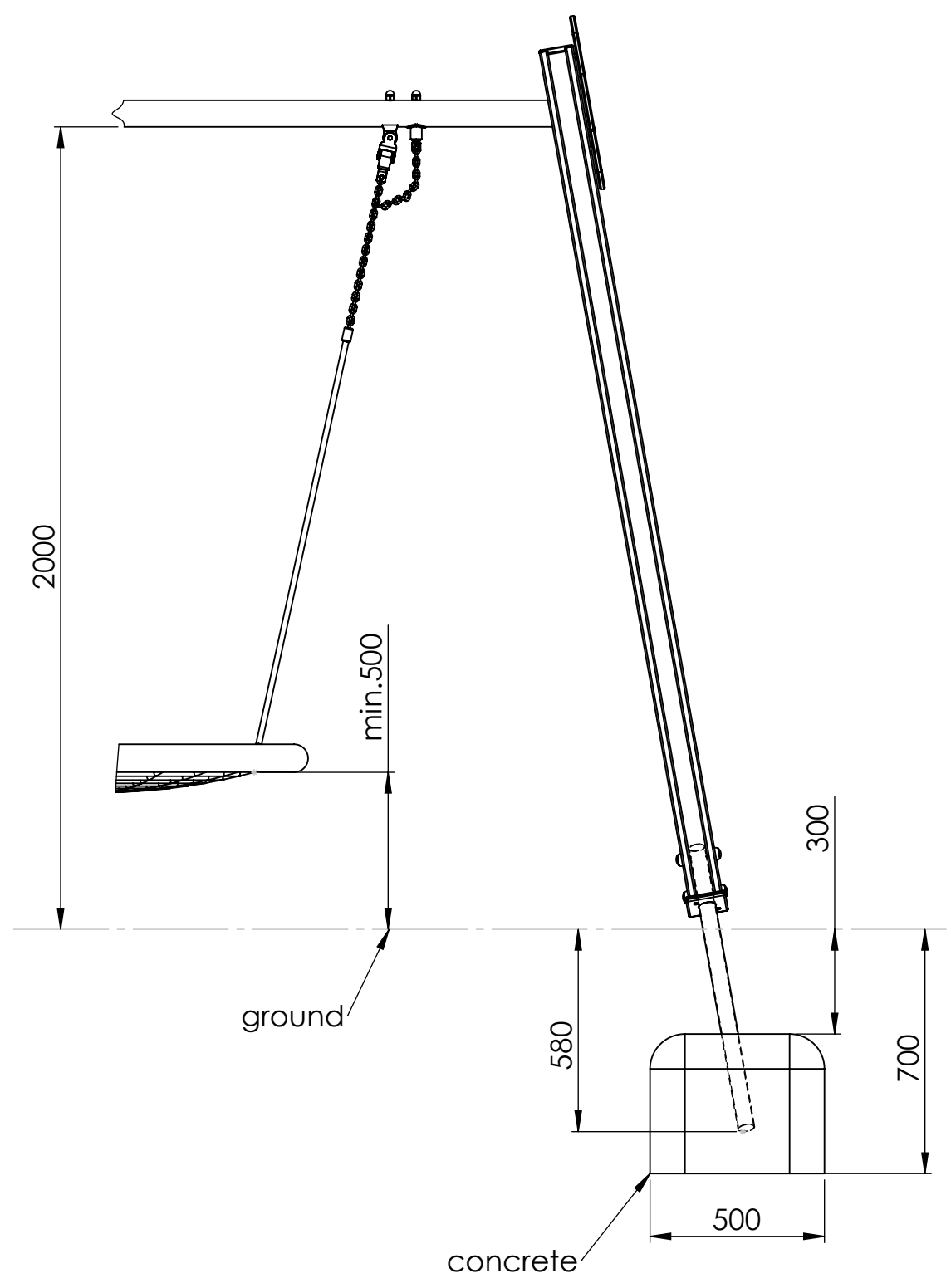

UNLESS OTHERWISE SPECIFIED:  
 DIMENSIONS ARE IN MILLIMETERS  
 WEIGHT ARE IN KILOGRAMM

PART NUMBER / DWG NO.:

K002-1

	NAME	SIGNATURE	DATE	REVISION
DRAWN	M.Rebase		05.08.2025	
APPV'D				

DESCRIPTION:

Swing BELL-FLOWER 2 places



Tiptiptap<sup>ÖÜ</sup>

MATERIAL:

A4

WEIGHT:

SCALE: 1:18

SHEET 11 OF 12

A

B

C

D

E

F



DETAIL A  
SCALE 1 : 5

domed cap nut M16 DIN986

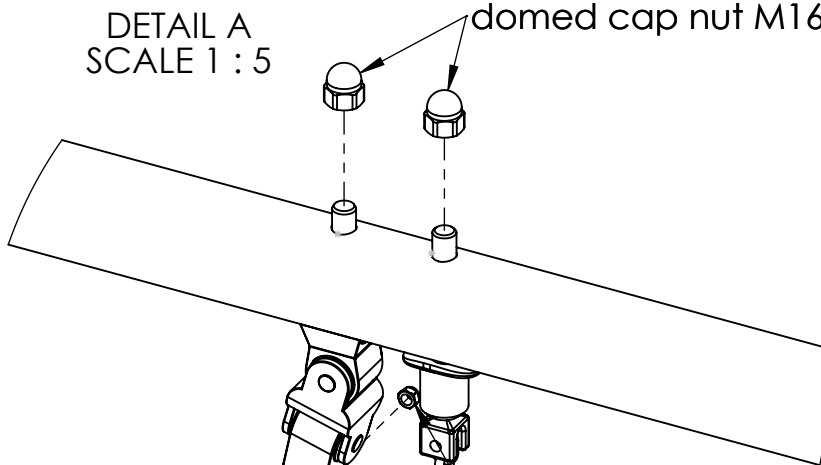

bolt M8x35 DIN933

nut M8 DIN985

shackle pin

shackle

safety chain for birdnest

UNLESS OTHERWISE SPECIFIED:  
DIMENSIONS ARE IN MILLIMETERS  
WEIGHT ARE IN KILOGRAMM

PART NUMBER / DWG NO.:

K002-1

	NAME	SIGNATURE	DATE	REVISION
DRAWN	M.Rebase		05.08.2025	
APPV'D				

DESCRIPTION:

Swing BELL-FLOWER 2 places

MATERIAL:

A4

WEIGHT:

SCALE: 1:35

SHEET 12 OF 12



Tiptiptap<sup>ÖÜ</sup>