

A

B

C

D

E

F

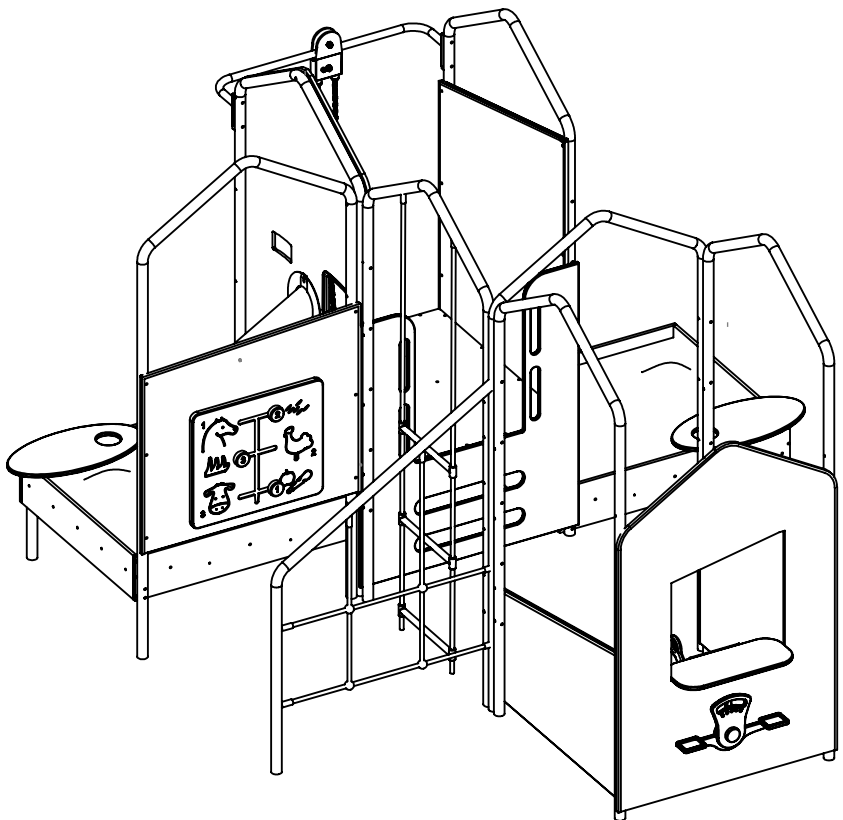
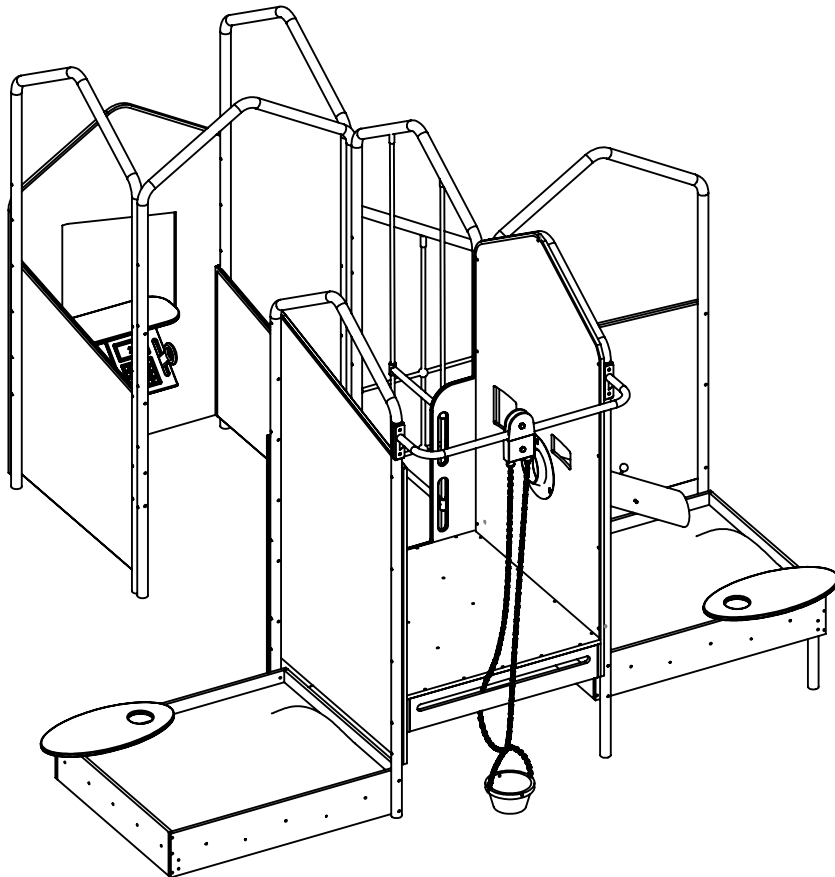

UNLESS OTHERWISE SPECIFIED:  
 DIMENSIONS ARE IN MILLIMETERS  
 WEIGHT ARE IN KILOGRAMM

	NAME	SIGNATURE	DATE	REVISION
DRAWN	E.Reispere		18.10.2023	
APPV'D				

PART NUMBER / DWG NO.: **FARM 2**

DESCRIPTION:  
**Farming complex medium**



**Tiptiptap** OÜ  
 Veetorni 9,  
 Jüri alevik, Rae vald,  
 75301 Harjumaa

MATERIAL:	wood, metal, plastic	A4
WEIGHT:		SCALE: 1:100
		SHEET 1 OF 7

# safety area

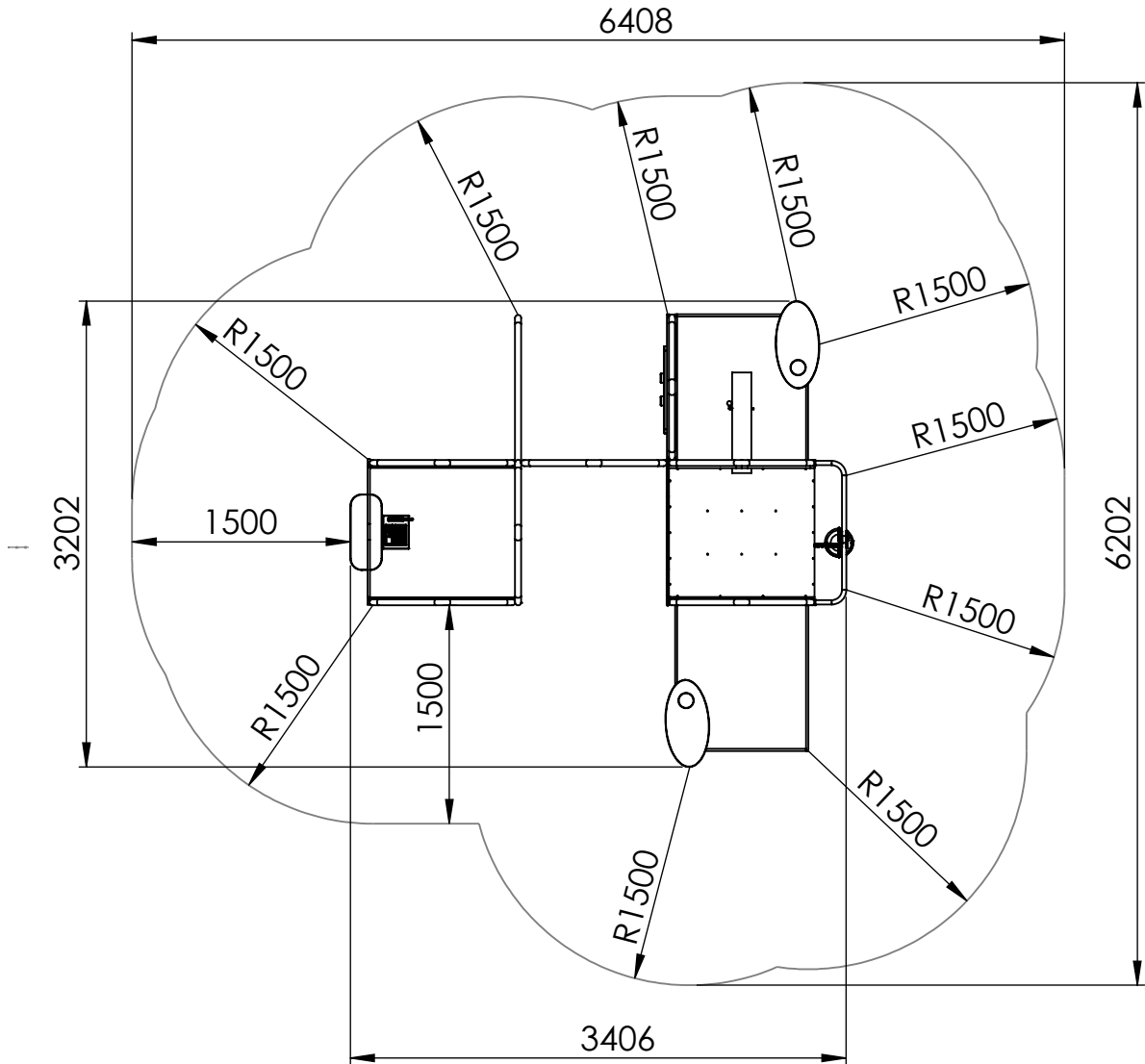

safety area: 30,96 m<sup>2</sup>

UNLESS OTHERWISE SPECIFIED:  
DIMENSIONS ARE IN MILLIMETERS  
WEIGHT ARE IN KILOGRAMM

PART NUMBER / DWG NO.:

FARM 2

	NAME	SIGNATURE	DATE	REVISION
DRAWN	E.Reispere		18.10.2023	
APPV'D				

DESCRIPTION:

Farming complex medium

MATERIAL:

wood, metal, plastic

A4

WEIGHT:

SCALE: 1:100

SHEET 2 OF 7



**Tiptiptap** OÜ

# foundation

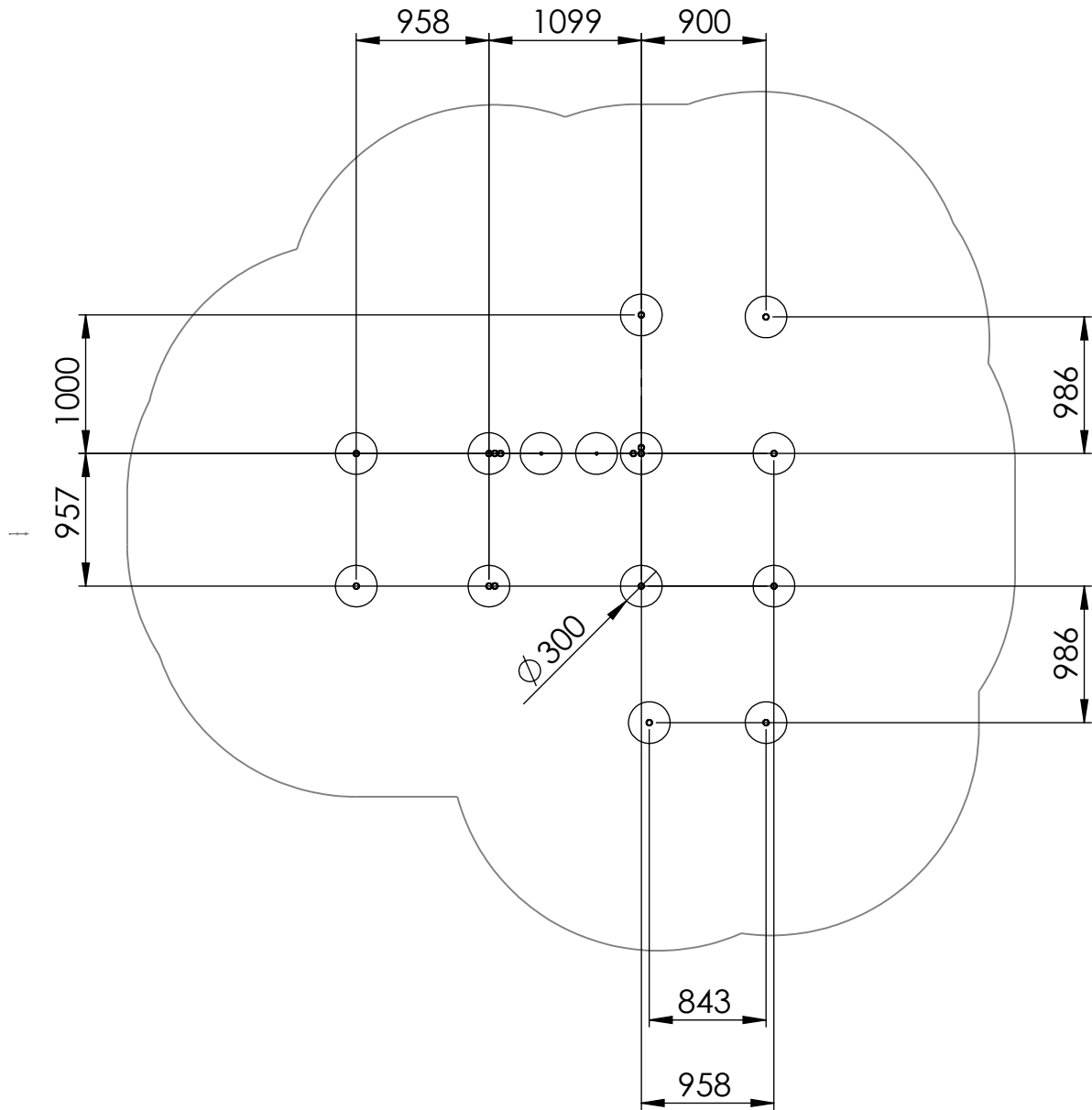

UNLESS OTHERWISE SPECIFIED:  
DIMENSIONS ARE IN MILLIMETERS  
WEIGHT ARE IN KILOGRAMM

PART NUMBER / DWG NO.:

FARM 2

	NAME	SIGNATURE	DATE	REVISION
DRAWN	E.Reispere		18.10.2023	
APPV'D				

DESCRIPTION:

Farming complex medium

MATERIAL:

wood, metal, plastic

A4

WEIGHT:

SCALE: 1:100

SHEET 3 OF 7



Tiptiptap OÜ

# dimensions

A

B

C

D

E

F

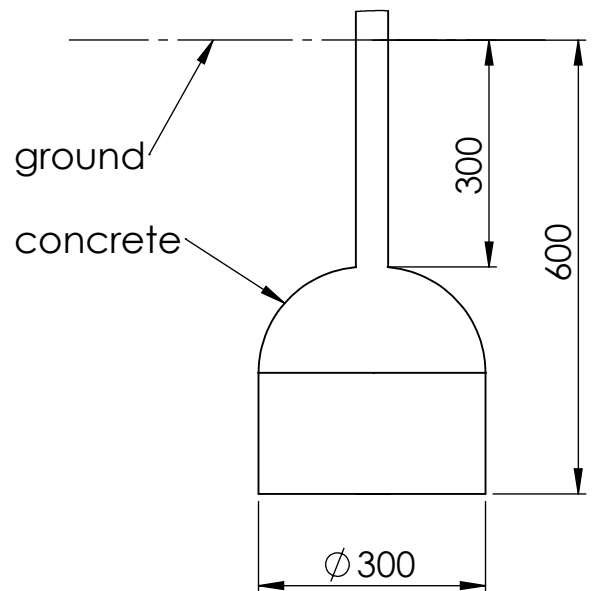
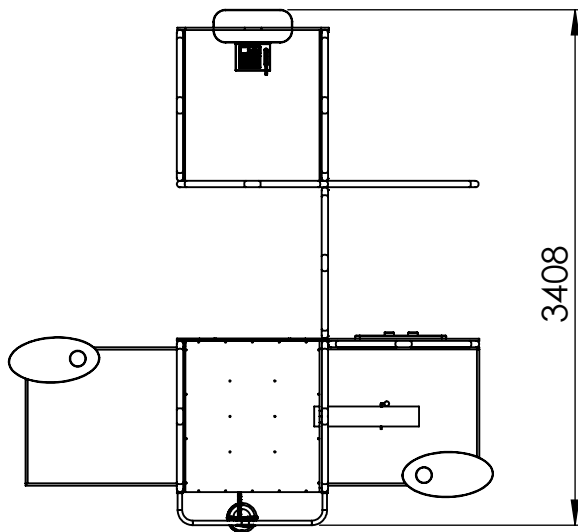
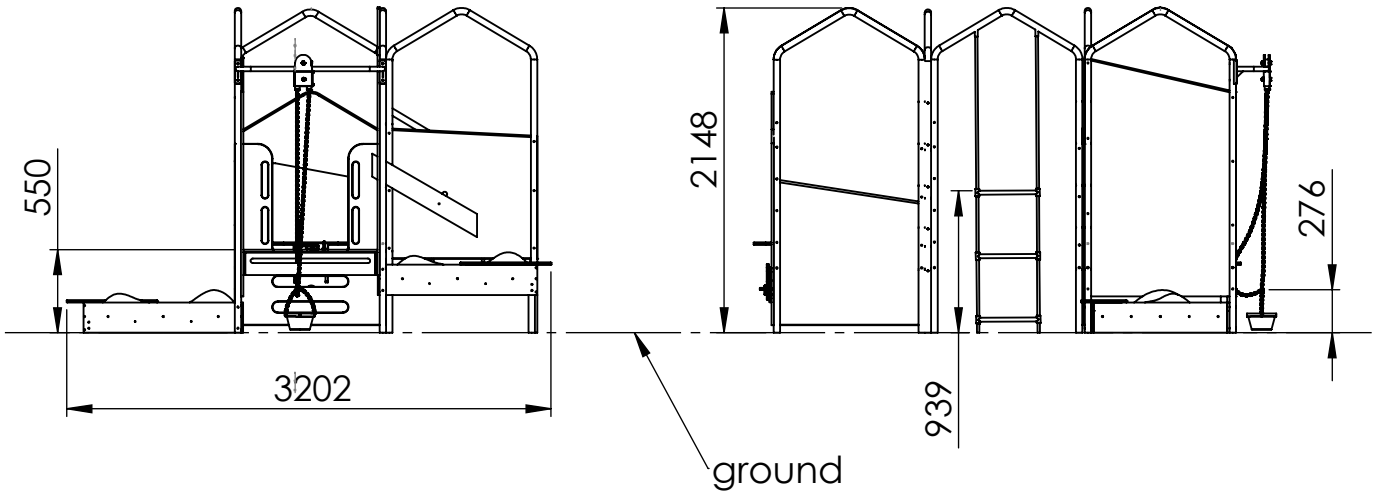

UNLESS OTHERWISE SPECIFIED:  
DIMENSIONS ARE IN MILLIMETERS  
WEIGHT ARE IN KILOGRAMM

PART NUMBER / DWG NO.:

FARM 2

	NAME	SIGNATURE	DATE	REVISION
DRAWN	E.Reispere		18.10.2023	
APPV'D				

DESCRIPTION:

Farming complex medium

MATERIAL:

wood, metal, plastic

A4

WEIGHT:

SCALE: 1:50

SHEET 4 OF 7



**Tiptiptap** OÜ

A

B

C

D

E

F

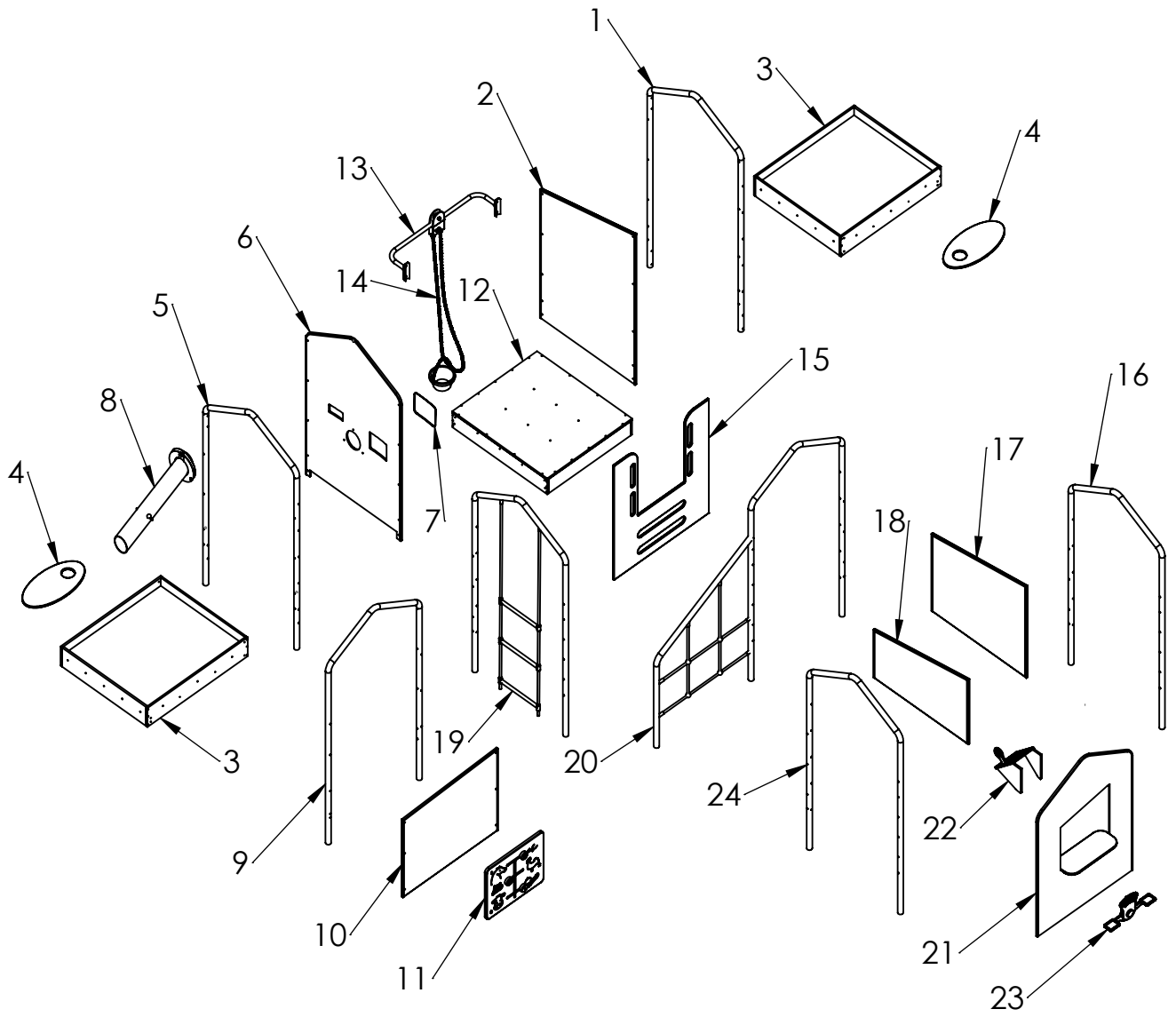

UNLESS OTHERWISE SPECIFIED:  
 DIMENSIONS ARE IN MILLIMETERS  
 WEIGHT ARE IN KILOGRAMM

PART NUMBER / DWG NO.:

FARM 2

	NAME	SIGNATURE	DATE	REVISION
DRAWN	E.Reispere		18.10.2023	
APPV'D				

DESCRIPTION:

Farming complex medium

MATERIAL:

wood, metal, plastic

A4

WEIGHT:

SCALE: 1:50

SHEET 5 OF 7



Tiptiptap OÜ

	ITEM NO.	DESCRIPTION
A	1	Farm frame horse
	2	Farm panel horse
	3	Farm sandbox
	4	Farm sandbox corner panel
B	5	Farm frame grain dryer
	6	Farm panel grain dryer
	7	Farm glass 001
	8	sandrohr
	9	Farm frame chicken
	10	Farm panel chicken
	11	Farm game panel 002
C	12	Farm platform
	13	sand lift rail
	14	moveable sand lift
	15	Farm ladder panel
	16	Farm frame goat
	17	Farm panel goat
D	18	Farm panel pig
	19	Farm frame with ladder
	20	Farm frame with net
	21	Farm panel shop 1
	22	Farm cash register
	23	Farm weighing machine
	24	Farm frame pig

E

UNLESS OTHERWISE SPECIFIED:  
DIMENSIONS ARE IN MILLIMETERS  
WEIGHT ARE IN KILOGRAMM

PART NUMBER / DWG NO.:

FARM 2

	NAME	SIGNATURE	DATE	REVISION
DRAWN	E.Reispere		18.10.2023	
APPV'D				

DESCRIPTION:

Farming complex medium

F



**Tiptiptap** <sup>00</sup>

MATERIAL:

wood, metal, plastic

A4

WEIGHT:

SCALE: 1:50

SHEET 6 OF 7

# Farm panel grain dryer

A

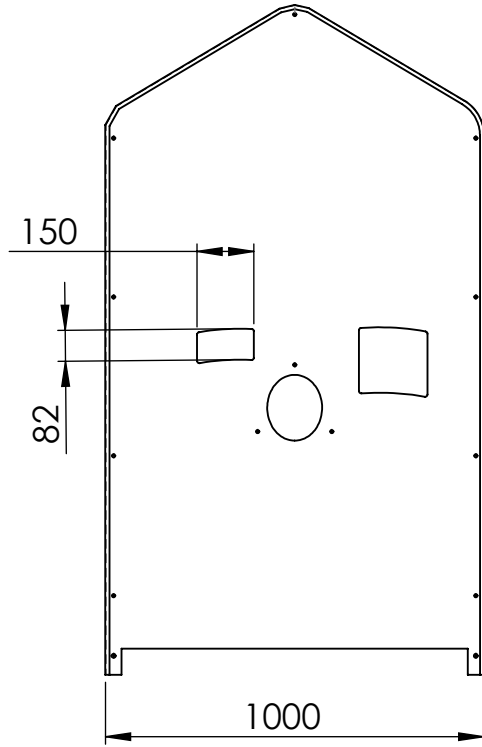

B

C

# Farm ladder

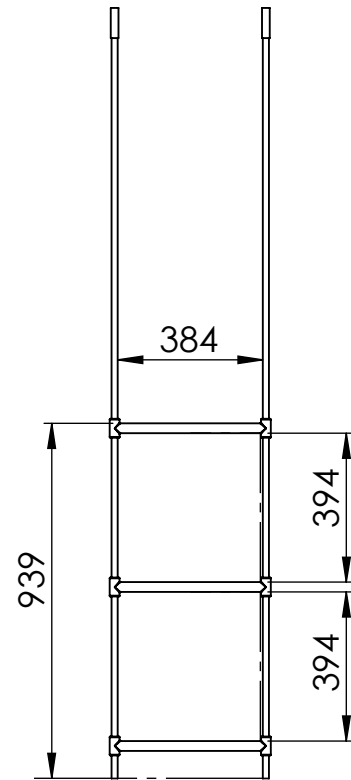

# Farm net

D

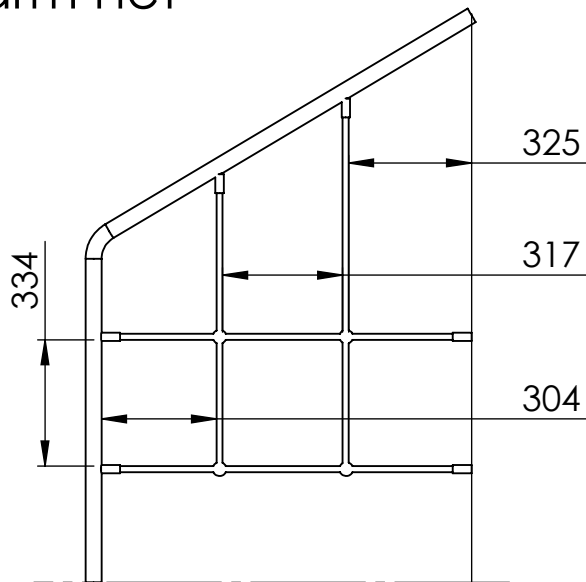

E

UNLESS OTHERWISE SPECIFIED:  
DIMENSIONS ARE IN MILLIMETERS  
WEIGHT ARE IN KILOGRAMM

PART NUMBER / DWG NO.:

## FARM 2

	NAME	SIGNATURE	DATE	REVISION
DRAWN	E.Reispere		18.10.2023	
APPV'D				

DESCRIPTION:

### Farming complex medium

F



# Tiptiptap<sup>OU</sup>

MATERIAL:

wood, metal, plastic

A4

WEIGHT:

SCALE: 1:50

SHEET 7 OF 7