

A

B

C

D

E

F

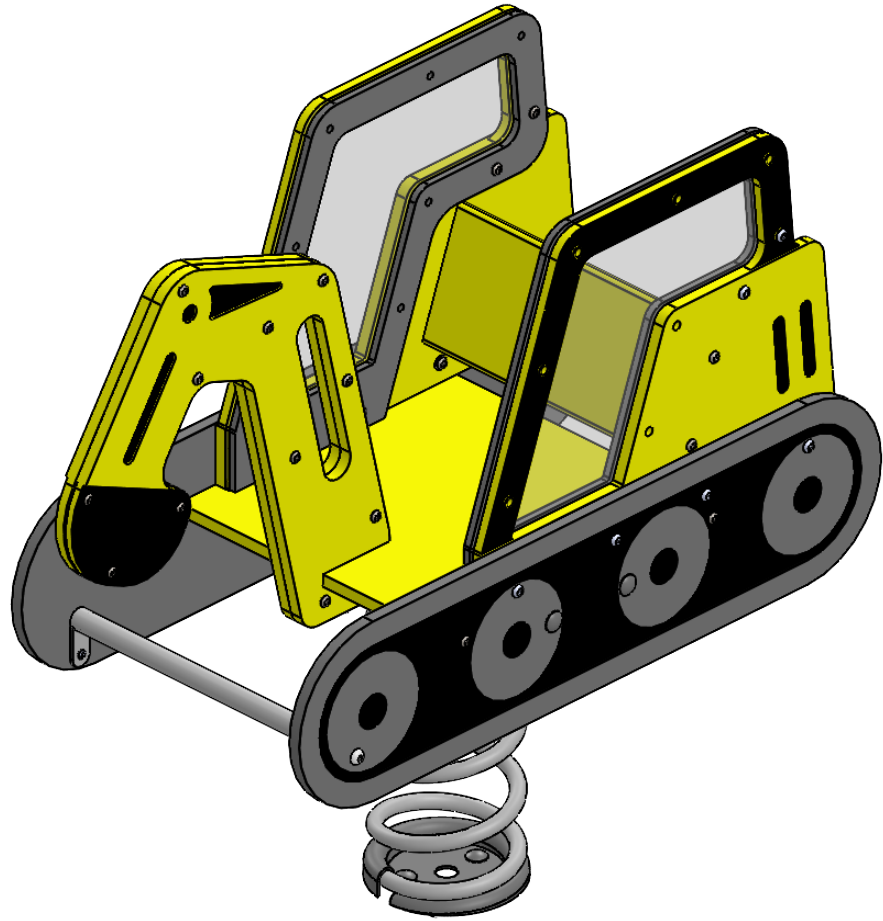

UNLESS OTHERWISE SPECIFIED:
 DIMENSIONS ARE IN MILLIMETERS
 WEIGHT ARE IN KILOGRAMM

PART NUMBER / DWG NO.:
VL62

	NAME	SIGNATURE	DATE	REVISION
DRAWN	E.Reispere		31.01.2025	
APPVD				

DESCRIPTION:
Spring swing EXCAVATOR



MATERIAL:	metal, plastic	A4
WEIGHT:		SCALE: 1:20
		SHEET 1 OF 14

safety area

A

B

C

D

E

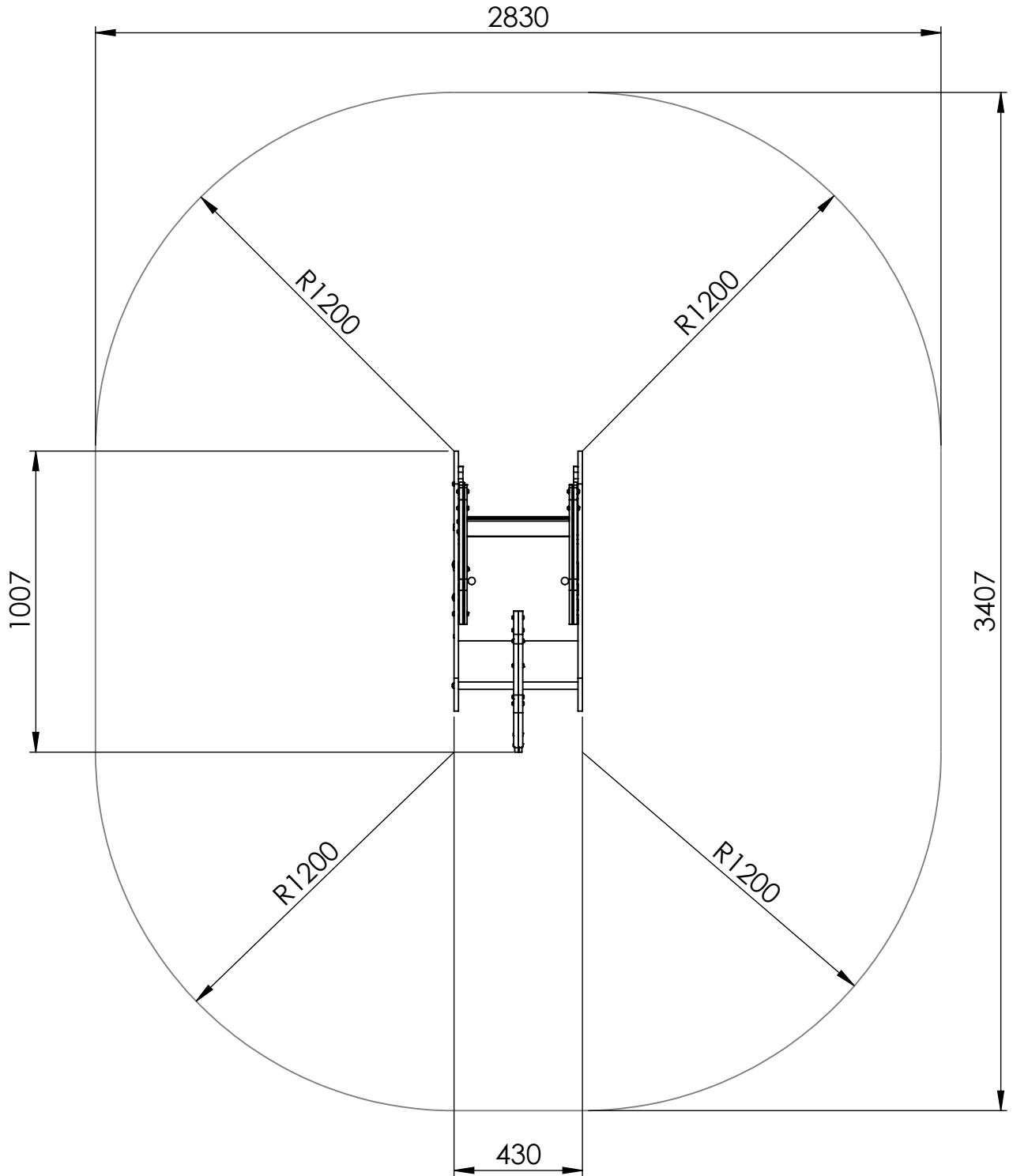

safety area: 8,42 m²

UNLESS OTHERWISE SPECIFIED:
DIMENSIONS ARE IN MILLIMETERS
WEIGHT ARE IN KILOGRAMM

PART NUMBER / DWG NO.:

VL62

	NAME	SIGNATURE	DATE	REVISION
DRAWN	E.Reispere		31.01.2025	
APPV'D				

DESCRIPTION:

Spring swing EXCAVATOR

F



Tiptiptap OÜ

MATERIAL:

metal, plastic

A4

WEIGHT:

SCALE: 1:20

SHEET 2 OF 14

foundation

A

B

C

D

E

2830

3407

Ø500

UNLESS OTHERWISE SPECIFIED:
DIMENSIONS ARE IN MILLIMETERS
WEIGHT ARE IN KILOGRAMM

PART NUMBER / DWG NO.:
VL62

	NAME	SIGNATURE	DATE	REVISION
DRAWN	E.Reispere		31.01.2025	
APPV'D				

DESCRIPTION:
Spring swing EXCAVATOR



MATERIAL:	metal, plastic	A4
-----------	----------------	----

WEIGHT:	SCALE: 1:20	SHEET 3 OF 14
---------	-------------	---------------

dimensions

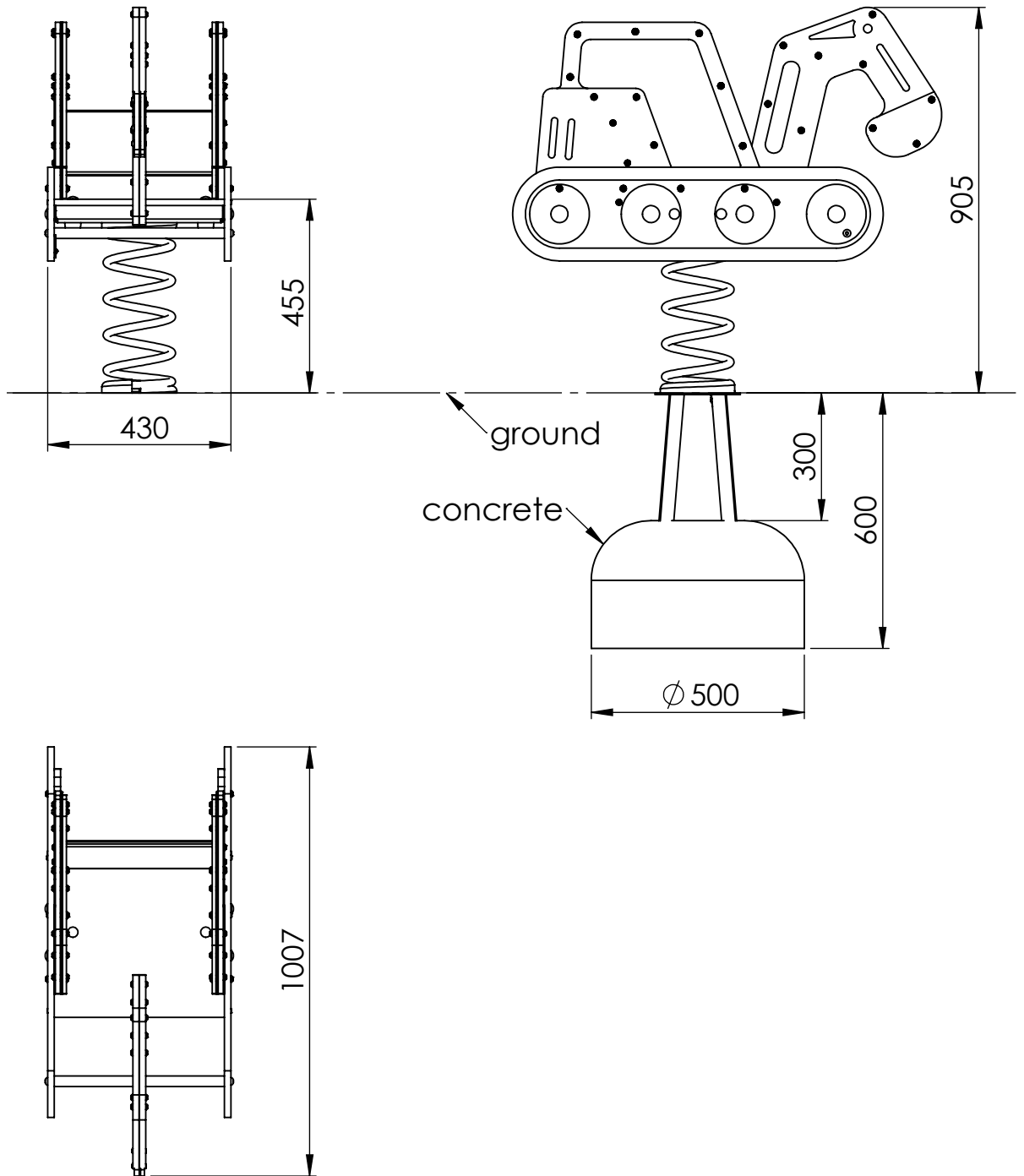

UNLESS OTHERWISE SPECIFIED:
DIMENSIONS ARE IN MILLIMETERS
WEIGHT ARE IN KILOGRAMM

PART NUMBER / DWG NO.:

VL62

	NAME	SIGNATURE	DATE	REVISION
DRAWN	E.Reispere		31.01.2025	
APPV'D				

DESCRIPTION:

Spring swing EXCAVATOR



Tiptap OÜ

MATERIAL:

metal, plastic

A4

WEIGHT:

SCALE: 1:20

SHEET 4 OF 14

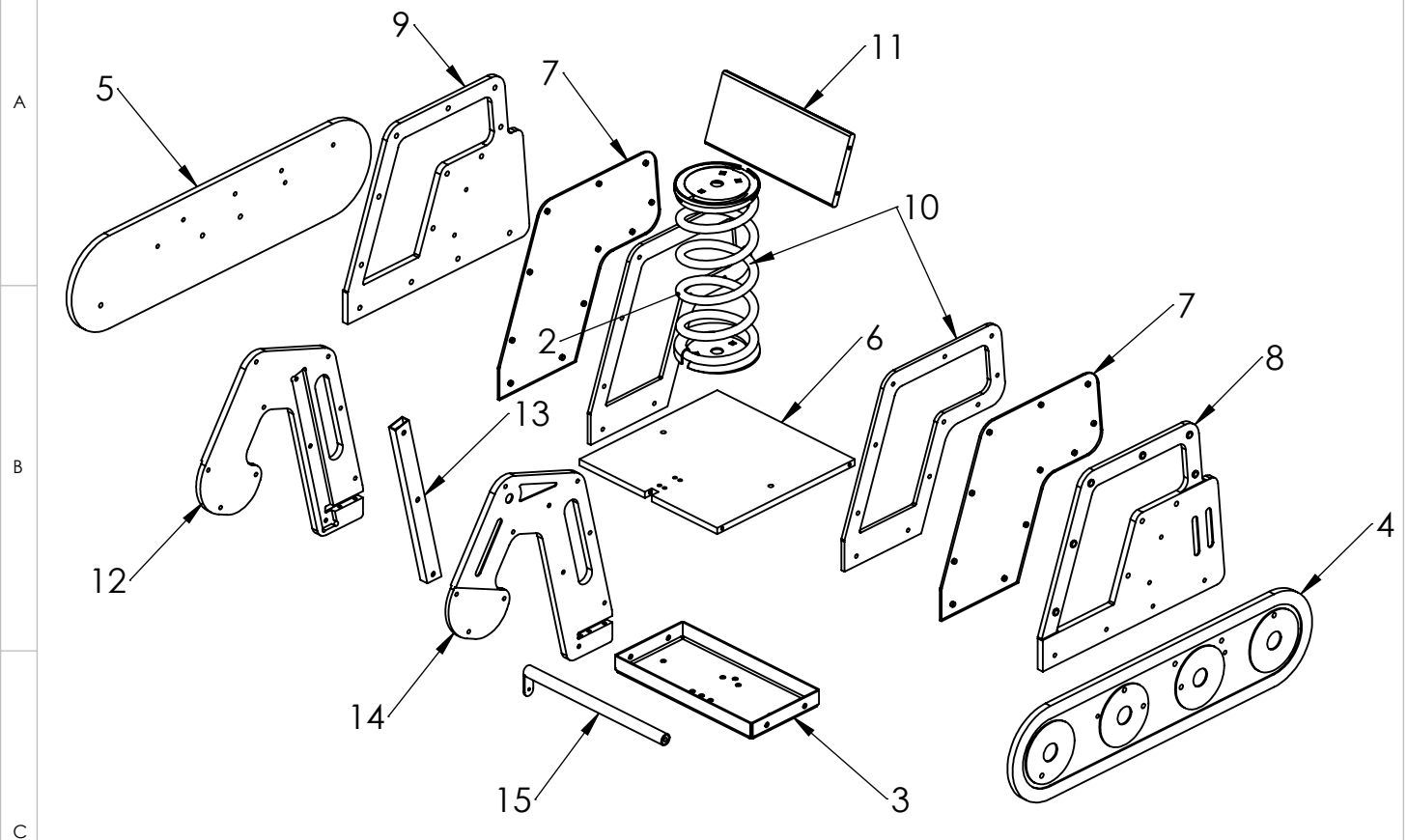

A

B

C

D

E

F

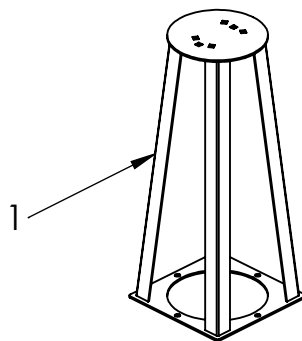

ITEM NO.	DESCRIPTION
1	ground fixing
2	springswing spring 170mm
3	central console
4	VL62 side detail 1
5	VL62 side detail 2
6	VL62 seat
7	VL62 glass
8	VL62 side detail 3
9	VL62 side detail 4
10	VL62 side detail 5
11	VL62 seat back panel
12	VL62 middle detail 1
13	VL62 middle detail support
14	VL62 middle detail 2
15	tube d.25x400

UNLESS OTHERWISE SPECIFIED:
DIMENSIONS ARE IN MILLIMETERS
WEIGHT ARE IN KILOGRAMM

PART NUMBER / DWG NO.:

VL62

	NAME	SIGNATURE	DATE	REVISION
DRAWN	E.Reispere		31.01.2025	
APPV'D				

DESCRIPTION:

Spring swing EXCAVATOR

MATERIAL:

metal, plastic

A4

WEIGHT:

SCALE: 1:20

SHEET 5 OF 14



Tiptiptap OÜ

A

B

C

D

E

F

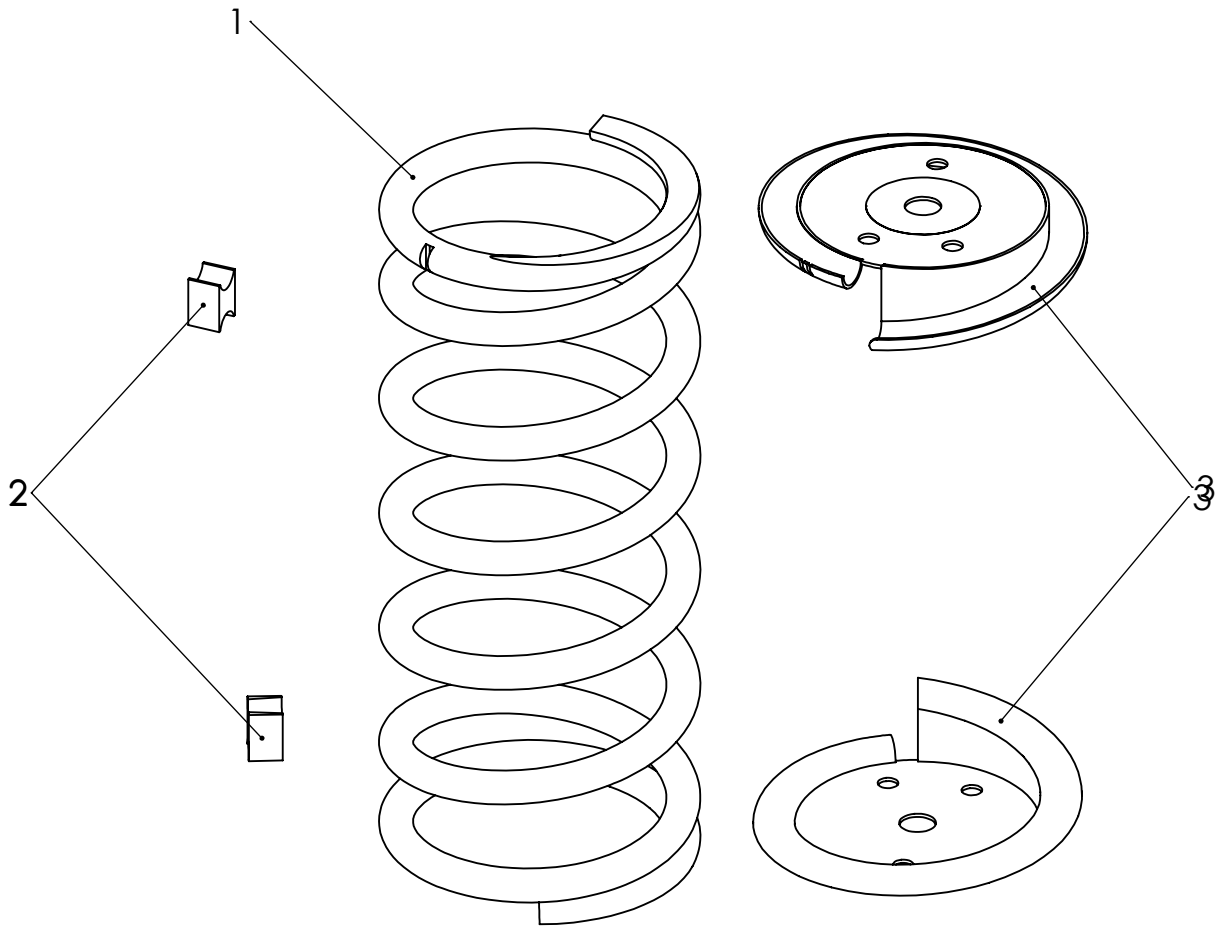

ITEM NO.	PART NUMBER	QTY.
1	spring	1
2	distance block	2
3	spring plate	2

UNLESS OTHERWISE SPECIFIED:
 DIMENSIONS ARE IN MILLIMETERS
 WEIGHT ARE IN KILOGRAMM

PART NUMBER / DWG NO.:

VL62

	NAME	SIGNATURE	DATE	REVISION
DRAWN	E.Reispere		31.01.2025	
APPV'D				

DESCRIPTION:

Spring swing EXCAVATOR



Tiptiptap OÜ

MATERIAL:

metal, plastic

A4

WEIGHT:

SCALE: 1:4

SHEET 6 OF 14

view 2

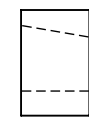
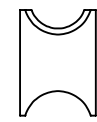
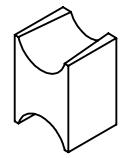

view 1

A

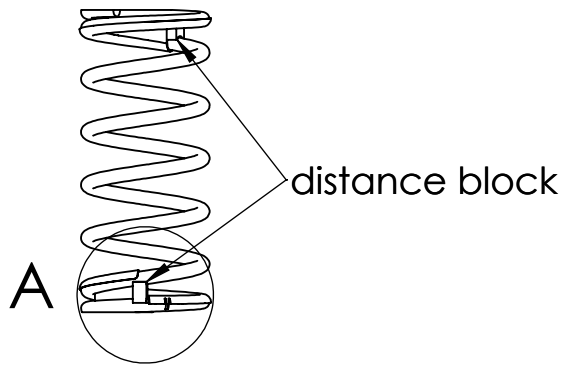

B

DETAIL A

spring plate

view 1

spring

C

distance block

view 2

D

spring

E

spring plate

distance block

UNLESS OTHERWISE SPECIFIED:
DIMENSIONS ARE IN MILLIMETERS
WEIGHT ARE IN KILOGRAMM

PART NUMBER / DWG NO.:

VL62

	NAME	SIGNATURE	DATE	REVISION
DRAWN	E.Reispere		31.01.2025	
APPV'D				

DESCRIPTION:

Spring swing EXCAVATOR

F



Tiptiptap OÜ

MATERIAL:

metal, plastic

A4

WEIGHT:

SCALE: 1:4

SHEET 7 OF 14

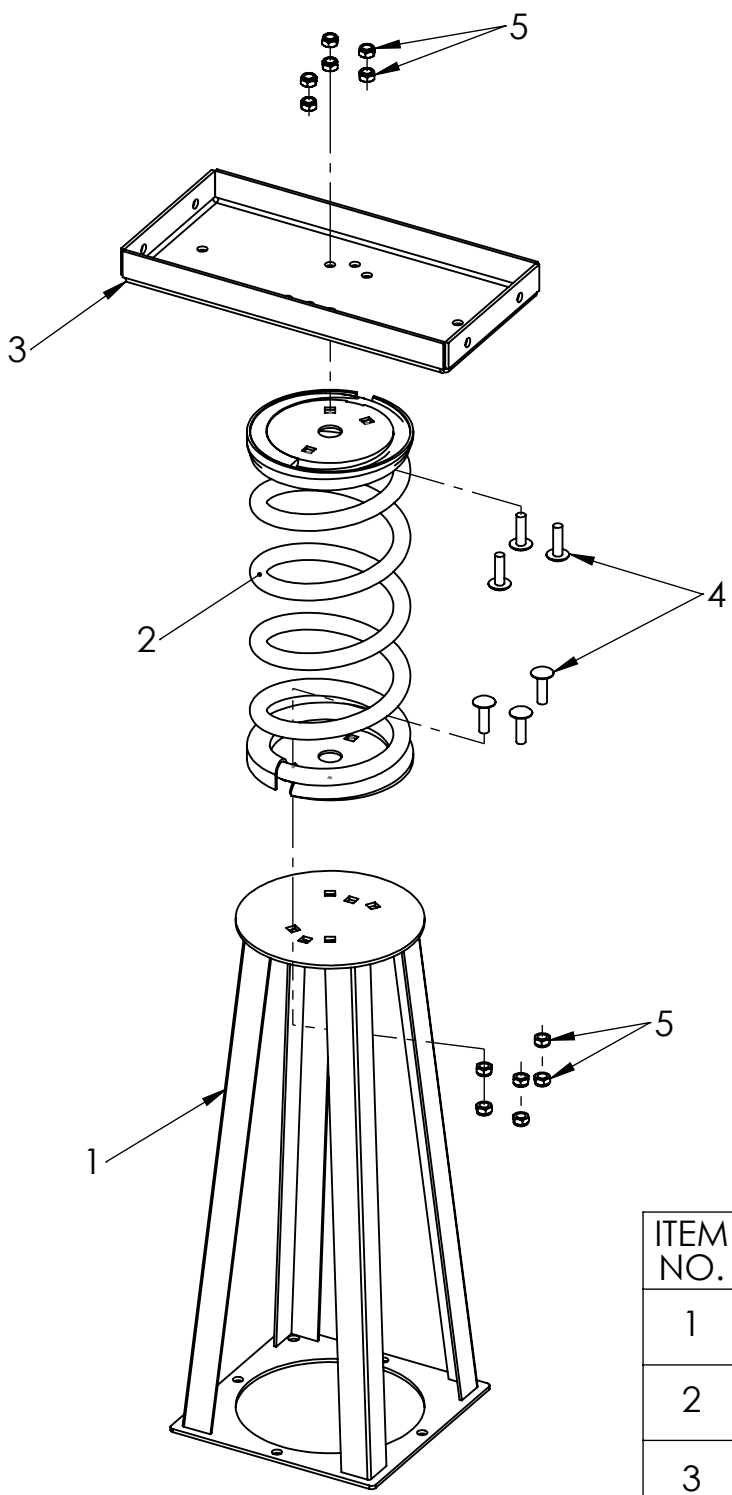

ITEM NO.	DESCRIPTION
1	ground fixing
2	springswing spring 170mm
3	central console
4	bolt M10x35 DIN603
5	nut M10 DIN985

UNLESS OTHERWISE SPECIFIED:
DIMENSIONS ARE IN MILLIMETERS
WEIGHT ARE IN KILOGRAMM

PART NUMBER / DWG NO.:
VL62

	NAME	SIGNATURE	DATE	REVISION
DRAWN	E.Reispere		31.01.2025	
APPV'D				

DESCRIPTION:
Spring swing EXCAVATOR



MATERIAL:	metal, plastic	A4
WEIGHT:		SCALE: 1:20
		SHEET 8 OF 14

A

B

C

D

E

F

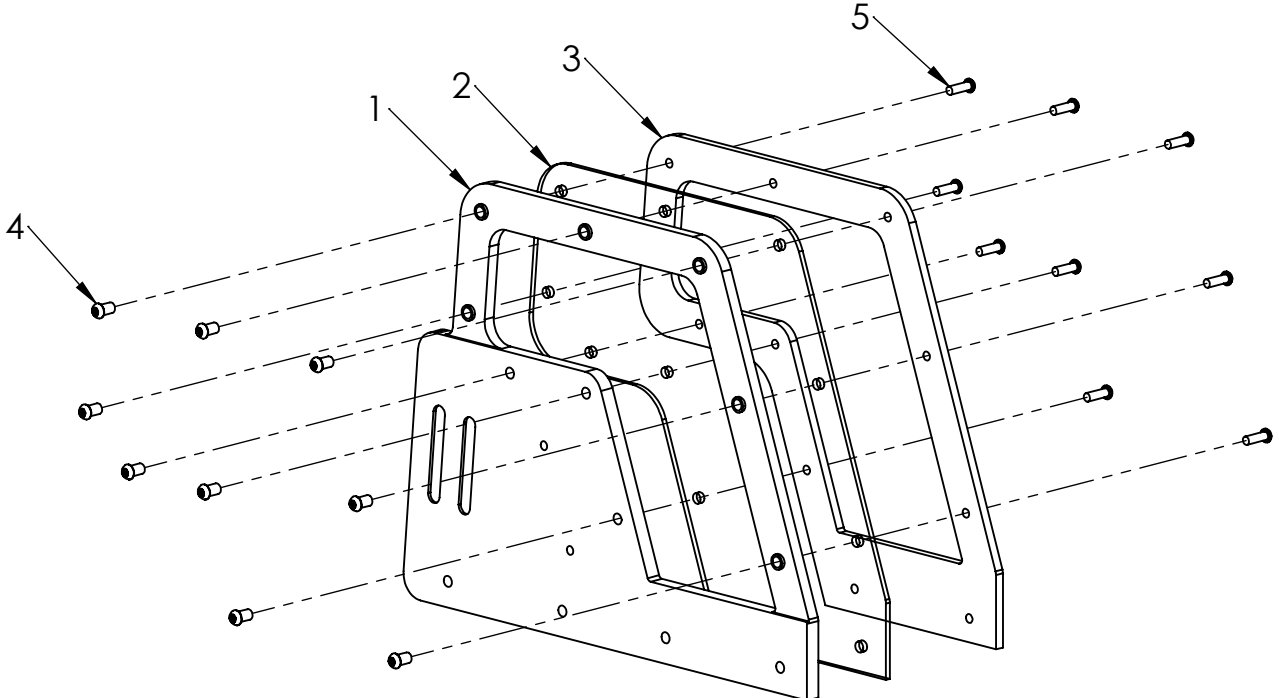

ITEM NO.	DESCRIPTION
1	VL62 side detail 4
2	VL62 glass
3	VL62 side detail 5
4	nut M8x16 Art. 9121
5	bolt M8x25 Art.9121

UNLESS OTHERWISE SPECIFIED: DIMENSIONS ARE IN MILLIMETERS WEIGHT ARE IN KILOGRAMM				
	NAME	SIGNATURE	DATE	REVISION
DRAWN	E.Reispere		31.01.2025	
APPV'D				

PART NUMBER / DWG NO.:	VL62
DESCRIPTION:	Spring swing EXCAVATOR



MATERIAL:	metal, plastic	A4
WEIGHT:		SCALE: 1:20
		SHEET 9 OF 14

A

B

C

D

E

F

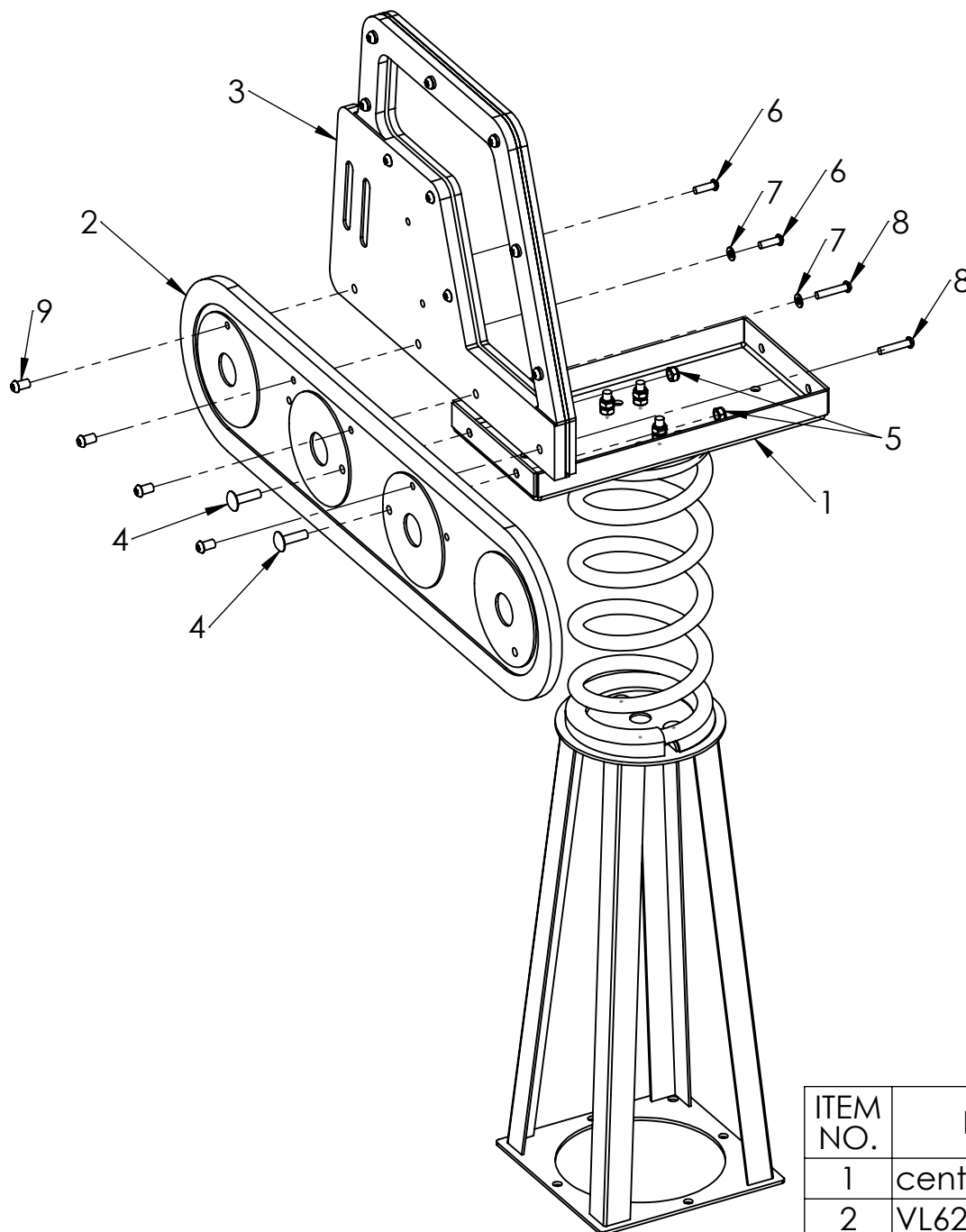

ITEM NO.	DESCRIPTION
1	central console
2	VL62 side detail 2
3	VL62 side detail 4
4	bolt M10x35 DIN603
5	nut M10 DIN985
6	bolt M8x25 Art.9121
7	washer M8 DIN125
8	bolt M8x40 Art.9121
9	nut M8x16 Art. 9121

UNLESS OTHERWISE SPECIFIED:
DIMENSIONS ARE IN MILLIMETERS
WEIGHT ARE IN KILOGRAMM

PART NUMBER / DWG NO.:

VL62

	NAME	SIGNATURE	DATE	REVISION
DRAWN	E.Reispere		31.01.2025	
APPV'D				

DESCRIPTION:

Spring swing EXCAVATOR

MATERIAL:

metal, plastic

A4

WEIGHT:

SCALE: 1:20

SHEET 10 OF 14



Tiptiptap OÜ

A

B

C

D

E

F

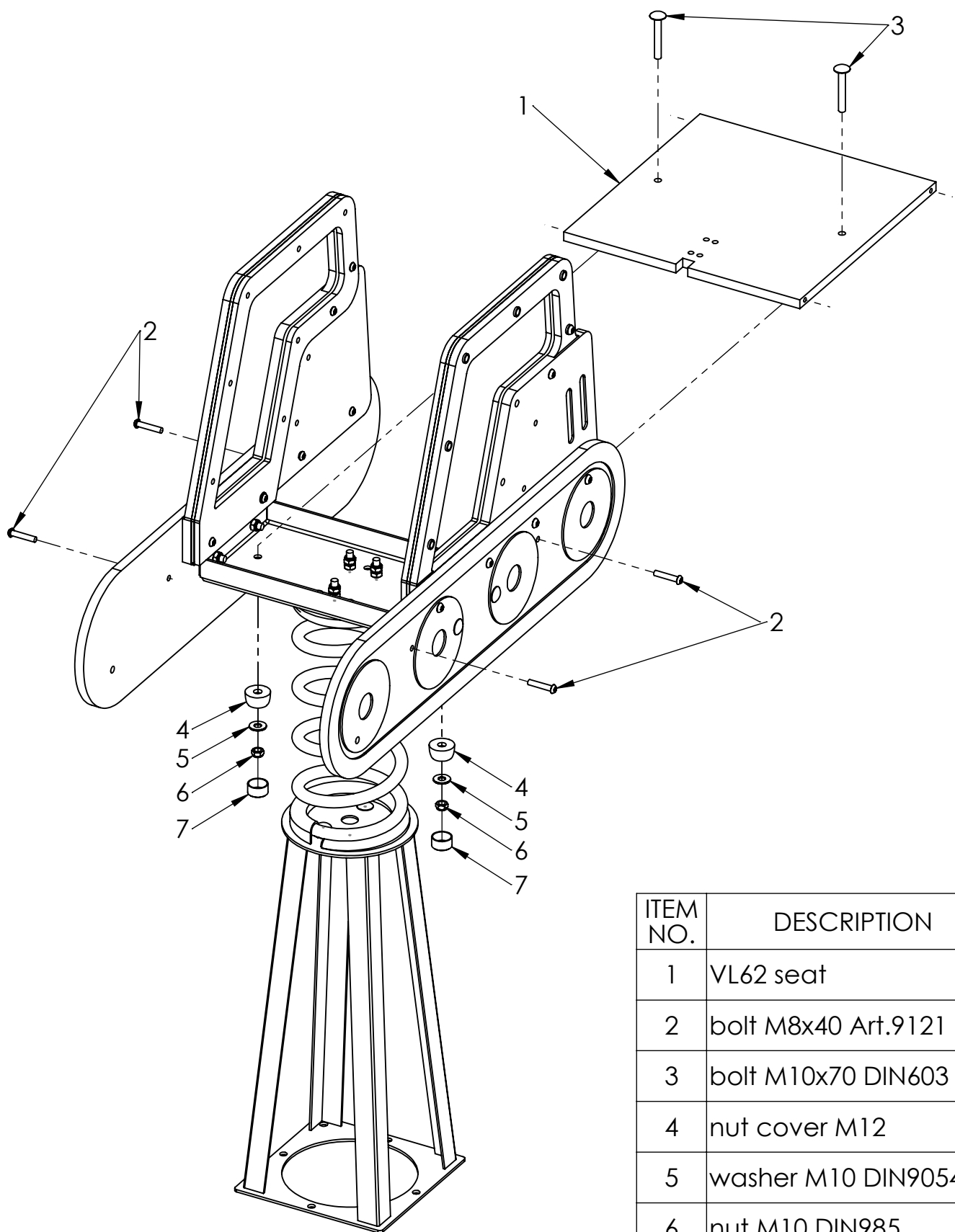

ITEM NO.	DESCRIPTION
1	VL62 seat
2	bolt M8x40 Art.9121
3	bolt M10x70 DIN603
4	nut cover M12
5	washer M10 DIN9054
6	nut M10 DIN985
7	nut cover cap M12

UNLESS OTHERWISE SPECIFIED:
DIMENSIONS ARE IN MILLIMETERS
WEIGHT ARE IN KILOGRAMM

PART NUMBER / DWG NO.:

VL62

	NAME	SIGNATURE	DATE	REVISION
DRAWN	E.Reispere		31.01.2025	
APPV'D				

DESCRIPTION:

Spring swing EXCAVATOR

MATERIAL:

metal, plastic

A4

WEIGHT:

SCALE: 1:20

SHEET 11 OF 14



Tiptap OÜ

A

B

C

D

E

F

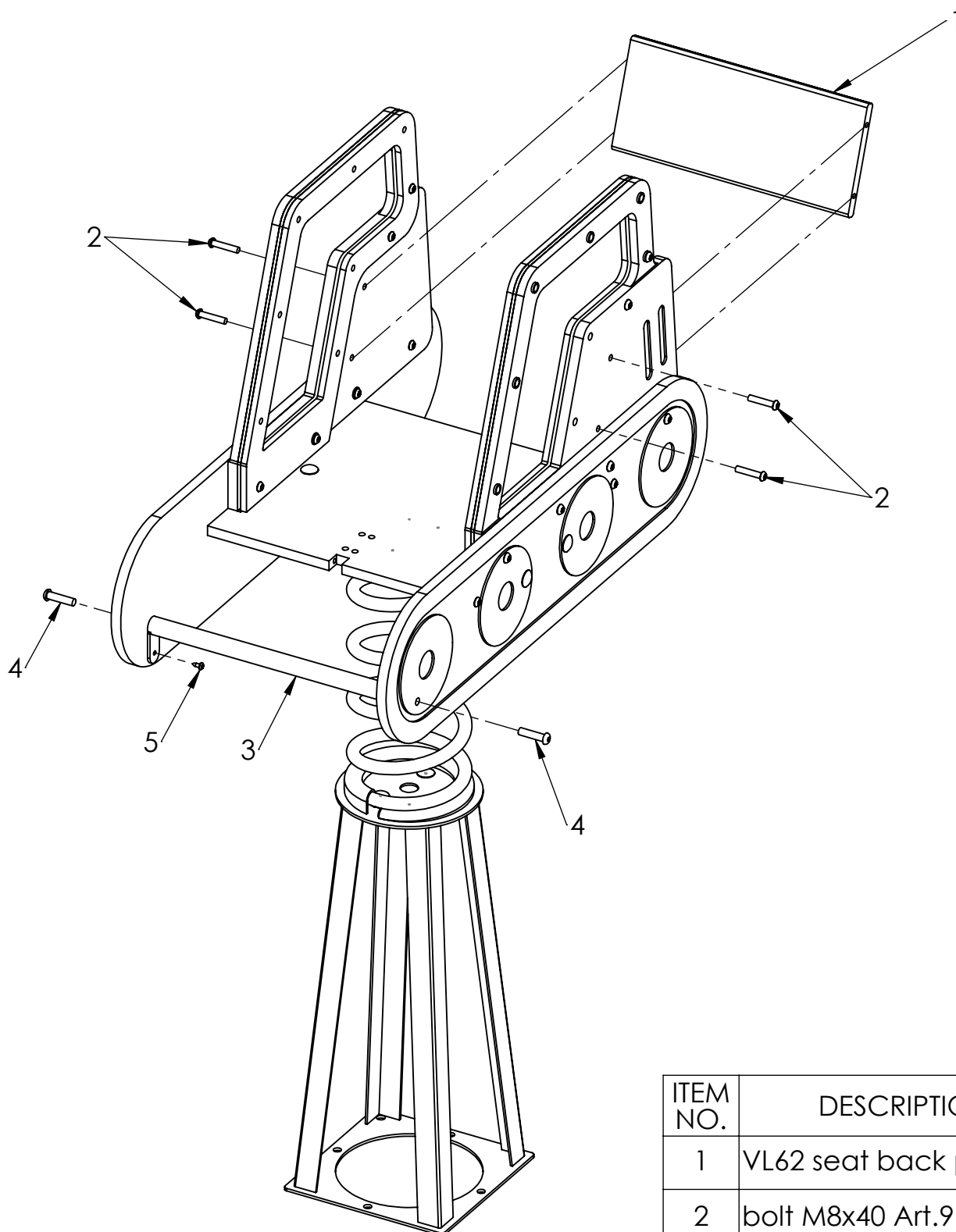

ITEM NO.	DESCRIPTION
1	VL62 seat back panel
2	bolt M8x40 Art.9121
3	tube d.25x400
4	bolt M10x40 Art. 9121
5	screw 4.8x13

UNLESS OTHERWISE SPECIFIED:
DIMENSIONS ARE IN MILLIMETERS
WEIGHT ARE IN KILOGRAMM

PART NUMBER / DWG NO.:

VL62

	NAME	SIGNATURE	DATE	REVISION
DRAWN	E.Reispere		31.01.2025	
APPV'D				

DESCRIPTION:

Spring swing EXCAVATOR

MATERIAL:

metal, plastic

A4

WEIGHT:

SCALE: 1:20

SHEET 12 OF 14



Tiptiptap OÜ

A

B

C

D

E

F

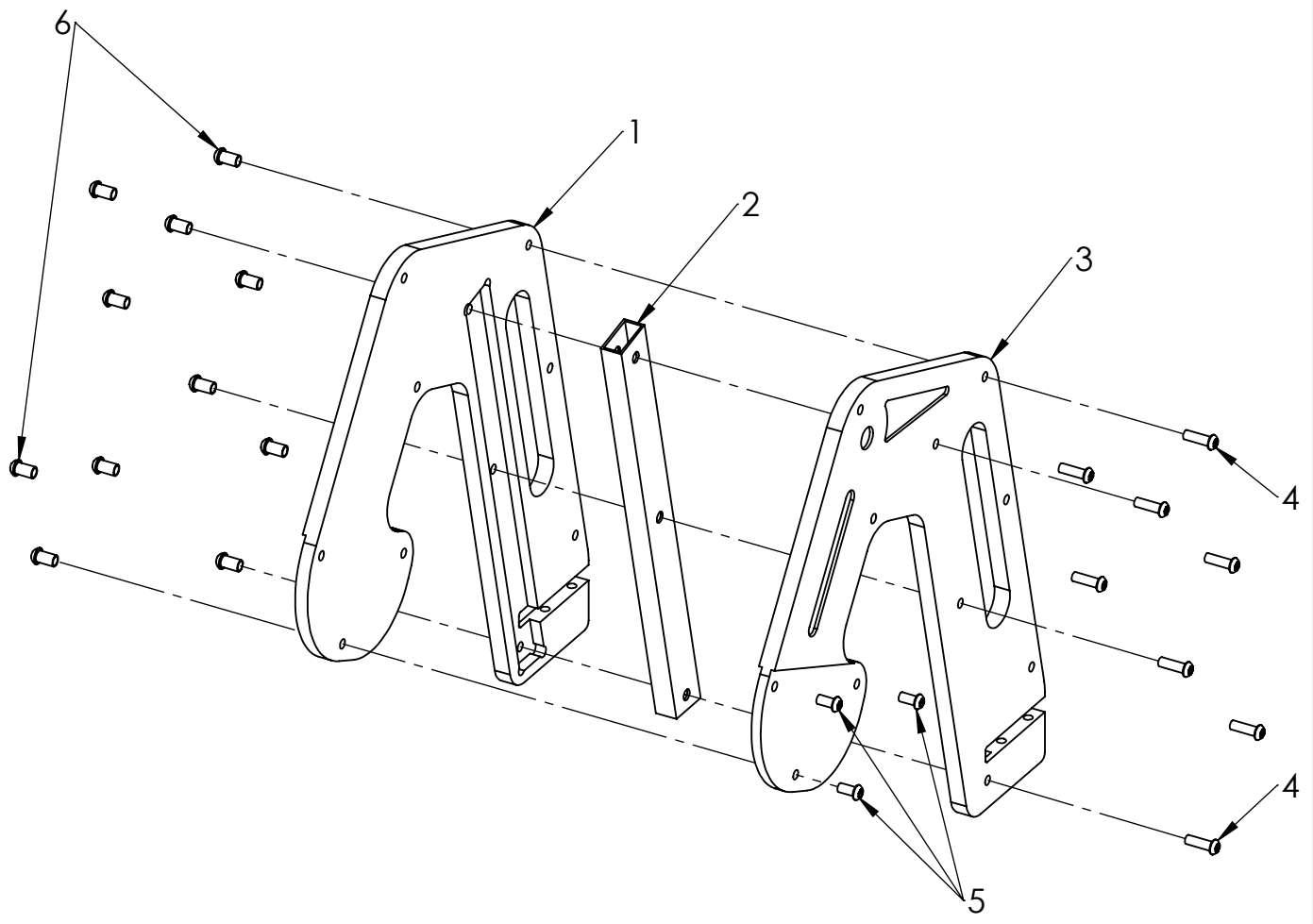

ITEM NO.	DESCRIPTION
1	VL62 middle detail 1
2	VL62 middle detail support
3	VL62 middle detail 2
4	bolt M8x25 Art.9121
5	bolt M8x16 Art. 9121
6	nut M8x16 Art. 9121

UNLESS OTHERWISE SPECIFIED: DIMENSIONS ARE IN MILLIMETERS WEIGHT ARE IN KILOGRAMM				
	NAME	SIGNATURE	DATE	REVISION
DRAWN	E.Reispere		31.01.2025	
APPV'D				

PART NUMBER / DWG NO.:		VL62	
DESCRIPTION:			
Spring swing EXCAVATOR			



MATERIAL:	metal, plastic	A4
WEIGHT:		SCALE: 1:20
		SHEET 13 OF 14

A

B

C

D

E

DETAIL E

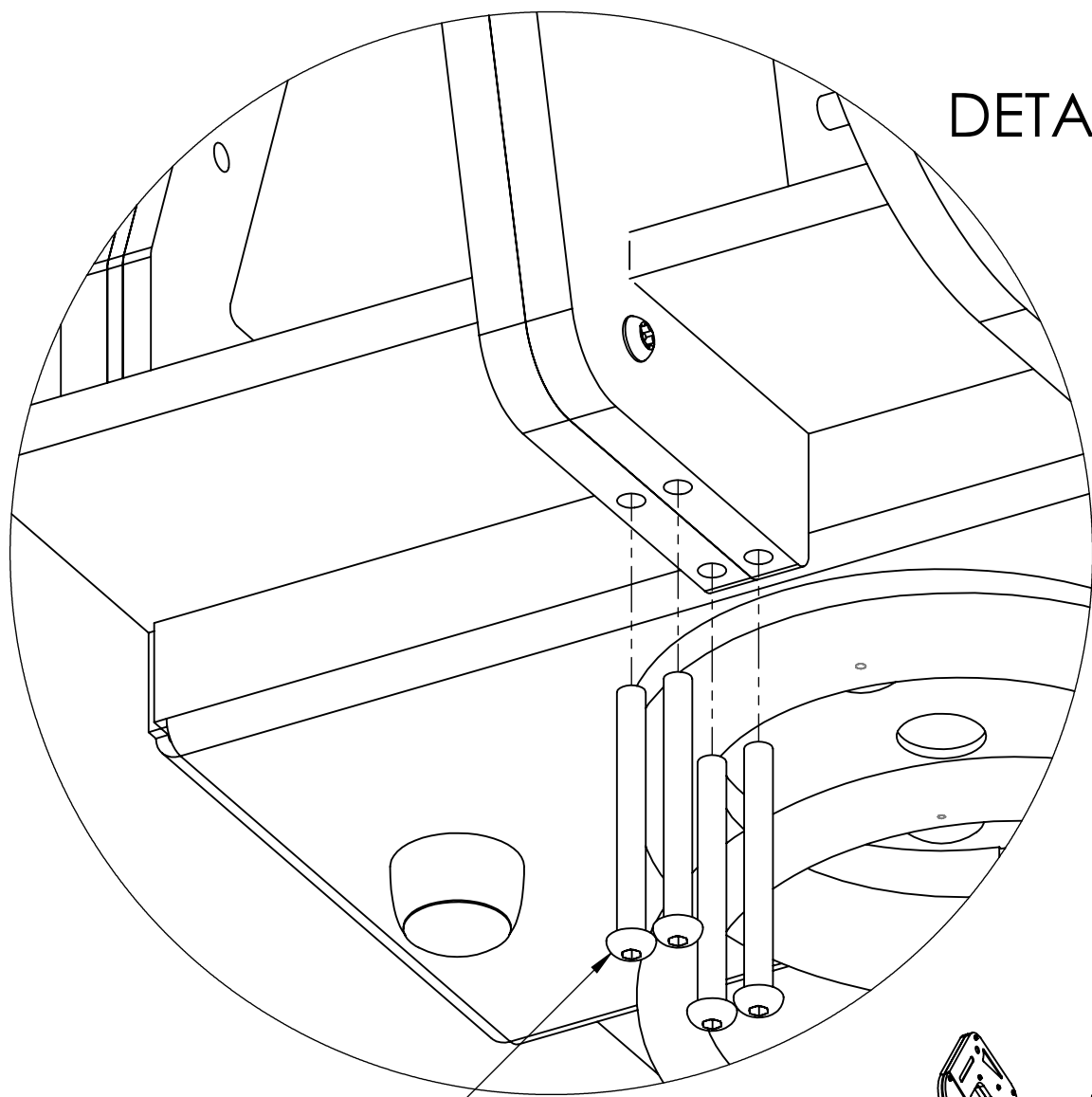

bolt M8x80xDIN7380

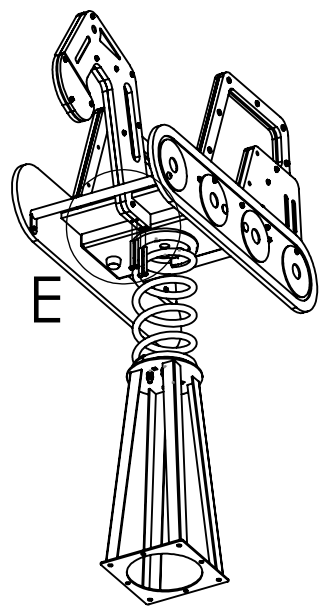

UNLESS OTHERWISE SPECIFIED: DIMENSIONS ARE IN MILLIMETERS WEIGHT ARE IN KILOGRAMM				
	NAME	SIGNATURE	DATE	REVISION
DRAWN	E.Reispere		31.01.2025	
APPV'D				

PART NUMBER / DWG NO.:
VL62

DESCRIPTION:
Spring swing EXCAVATOR



MATERIAL:	metal, plastic	A4
WEIGHT:	SCALE: 1:20	SHEET 14 OF 14