

A

B

C

D

E

F

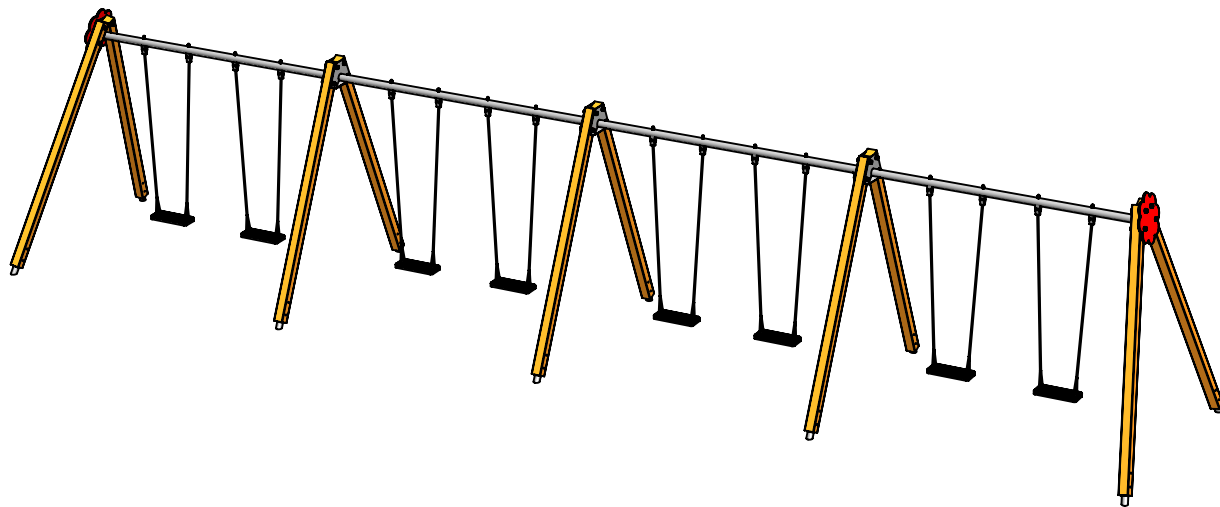

UNLESS OTHERWISE SPECIFIED:
 DIMENSIONS ARE IN MILLIMETERS
 WEIGHT ARE IN KILOGRAMM

PART NUMBER / DWG NO.:

K010

	NAME	SIGNATURE	DATE	REVISION
DRAWN	M.Rebase		11.03.2024	
APPV'D				

DESCRIPTION:

Swing BELL-FLOWER 8 places



Tiptiptap^{ÖÜ}

MATERIAL:

A4

WEIGHT:

SCALE: 1:65

SHEET 1 OF 13

safety area

A

B

C

D

E

F

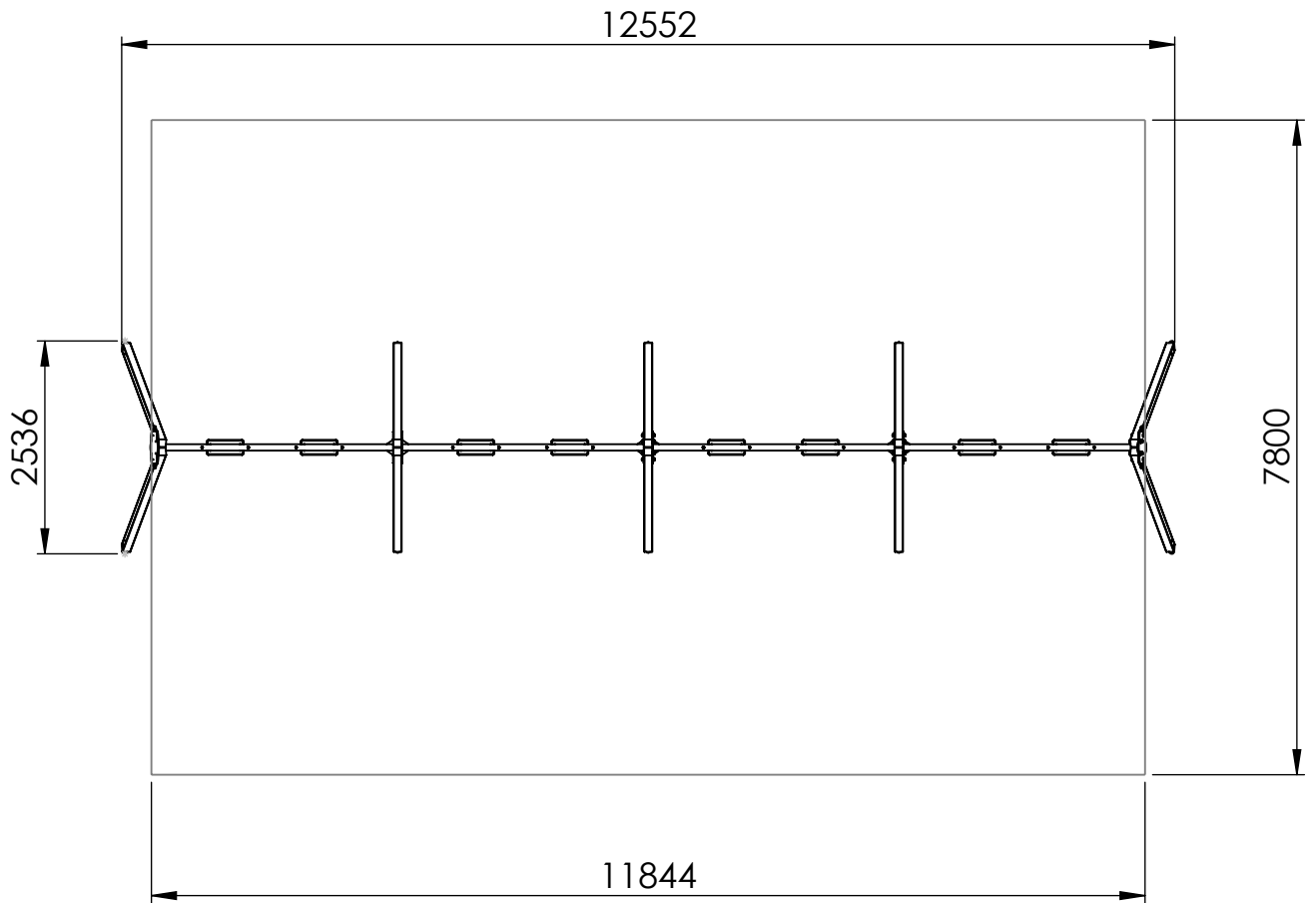

UNLESS OTHERWISE SPECIFIED:
DIMENSIONS ARE IN MILLIMETERS
WEIGHT ARE IN KILOGRAMM

PART NUMBER / DWG NO.:

K010

	NAME	SIGNATURE	DATE	REVISION
DRAWN	M.Rebase		11.03.2024	
APPV'D				

DESCRIPTION:

Swing BELL-FLOWER 8 places



Tiptiptap ^{ÖÜ}

MATERIAL:

A4

WEIGHT:

SCALE: 1:90

SHEET 2 OF 13

foundation

A

B

C

D

E

F

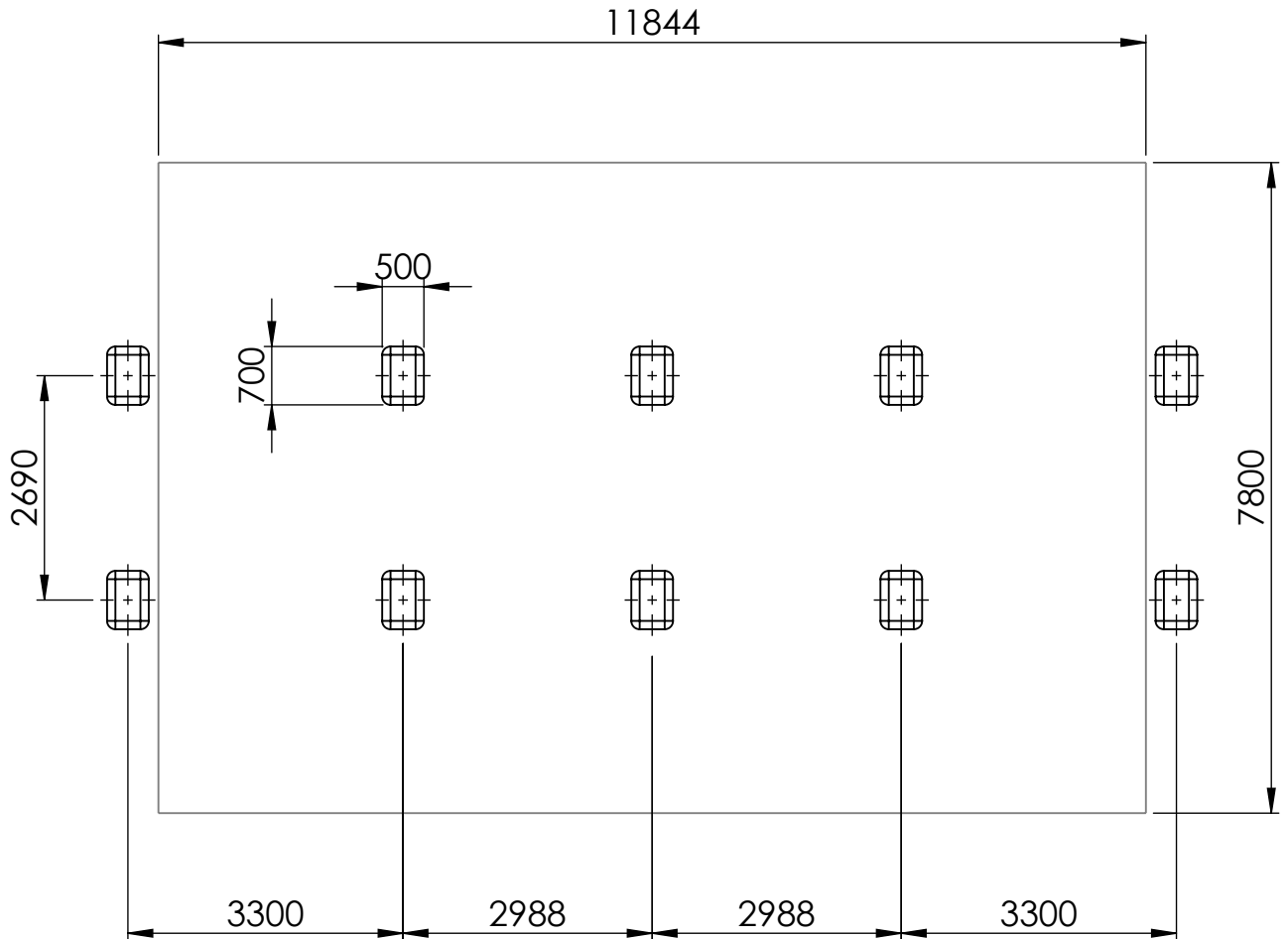

UNLESS OTHERWISE SPECIFIED:
DIMENSIONS ARE IN MILLIMETERS
WEIGHT ARE IN KILOGRAMM

PART NUMBER / DWG NO.:

K010

	NAME	SIGNATURE	DATE	REVISION
DRAWN	M.Rebase		11.03.2024	
APPV'D				

DESCRIPTION:

Swing BELL-FLOWER 8 places



Tiptiptap^{ÖÜ}

MATERIAL:

A4

WEIGHT:

SCALE: 1:90

SHEET 3 OF 13

A

B

C

D

E

F

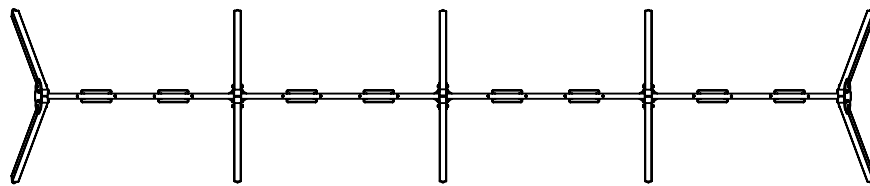
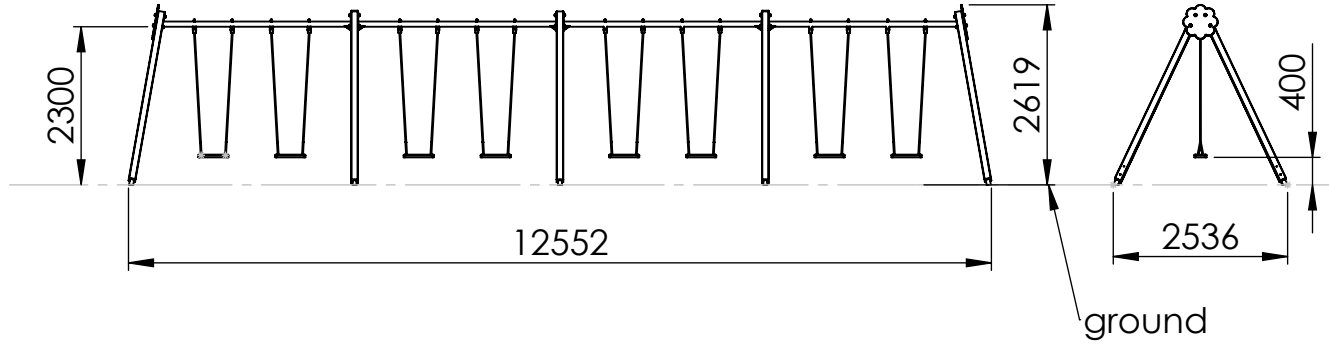

UNLESS OTHERWISE SPECIFIED:
 DIMENSIONS ARE IN MILLIMETERS
 WEIGHT ARE IN KILOGRAMM

PART NUMBER / DWG NO.:

K010

	NAME	SIGNATURE	DATE	REVISION
DRAWN	M.Rebase		11.03.2024	
APPV'D				

DESCRIPTION:

Swing BELL-FLOWER 8 places



Tiptiptap ^{ÖÜ}

MATERIAL:

A4

WEIGHT:

SCALE: 1:110

SHEET 4 OF 13

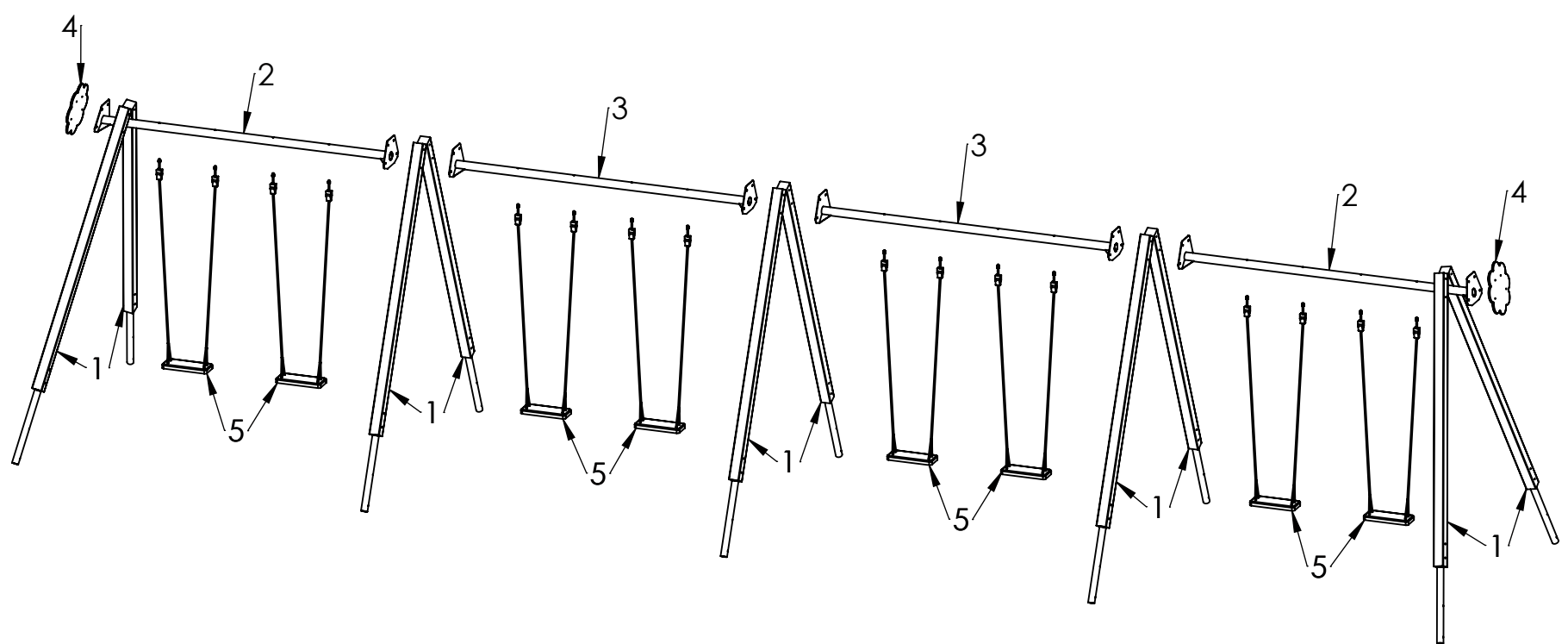

UNLESS OTHERWISE SPECIFIED:
 DIMENSIONS ARE IN MILLIMETERS
 WEIGHT ARE IN KILOGRAMM

	NAME	SIGNATURE	DATE	REVISION
DRAWN	M.Rebase		11.03.2024	
APPV'D				

PART NUMBER / DWG NO.:
K010

DESCRIPTION:
Swing BELL-FLOWER 8 places



MATERIAL:

WEIGHT: SCALE: 1:60 SHEET 5 OF 13

A4

1

2

3

4

ITEM NO.	PART NUMBER	QTY.
1	post 98x98x2720	10
2	beam 76x2860	2
3	beam 76x2890	2
4	side fixture	2
5	seat complet with fixings	8

A

B

C

D

E

UNLESS OTHERWISE SPECIFIED: DIMENSIONS ARE IN MILLIMETERS WEIGHT ARE IN KILOGRAMM				PART NUMBER / DWG NO.: K010	
	NAME	SIGNATURE	DATE	REVISION	DESCRIPTION: Swing BELL-FLOWER 8 places
DRAWN	M.Rebase		11.03.2024		
APPV'D					
 Tiptiptap ^{ÖÜ}				MATERIAL:	
				A4	
				WEIGHT:	
				SCALE: 1:50	
				SHEET 6 OF 13	

F

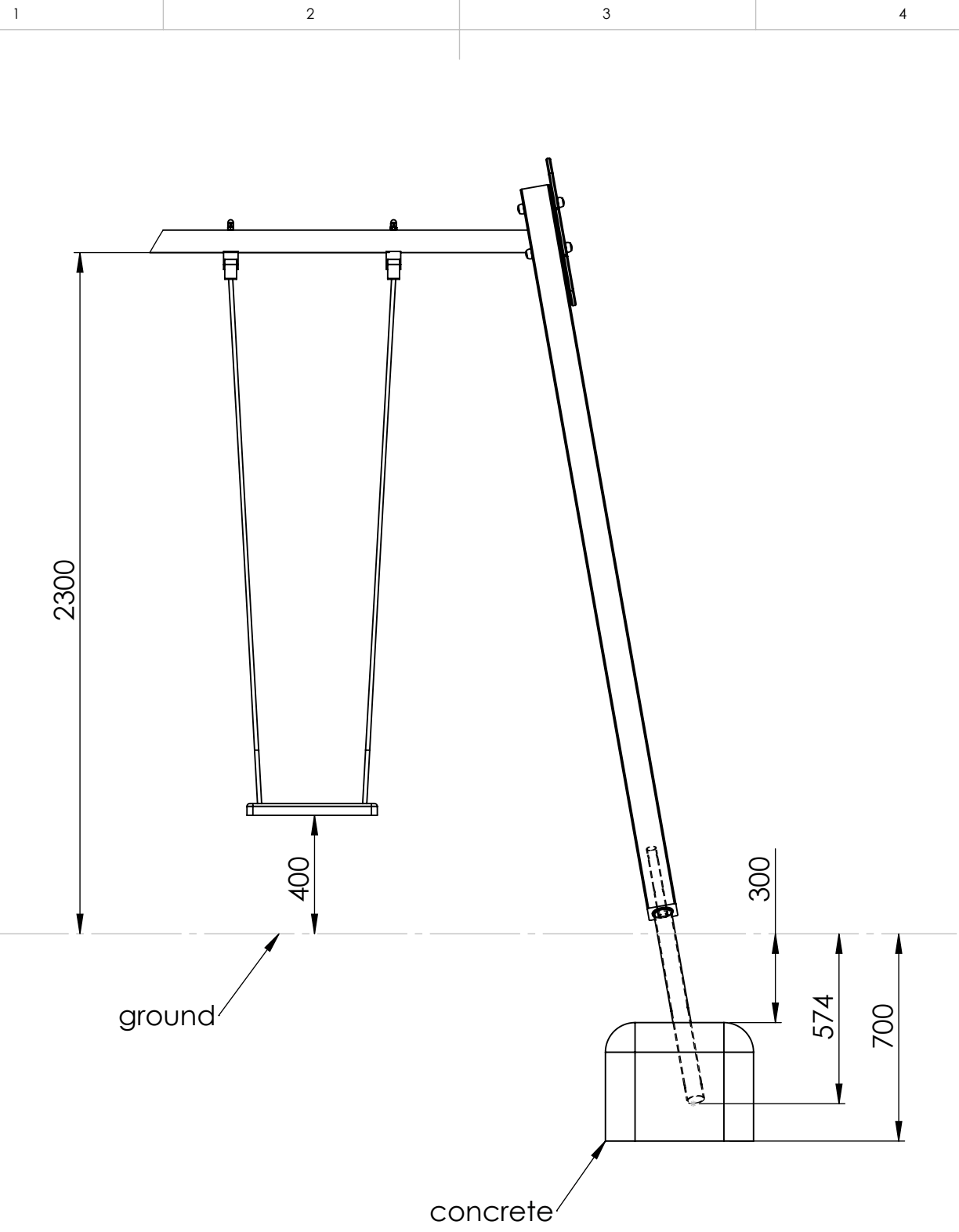

UNLESS OTHERWISE SPECIFIED:
DIMENSIONS ARE IN MILLIMETERS
WEIGHT ARE IN KILOGRAMM

PART NUMBER / DWG NO.:

K010

	NAME	SIGNATURE	DATE	REVISION
DRAWN	M.Rebase		11.03.2024	
APPV'D				

DESCRIPTION:

Swing BELL-FLOWER 8 places



Tiptiptap OÜ

MATERIAL:

A4

WEIGHT:

SCALE: 1:20

SHEET 7 OF 13

A

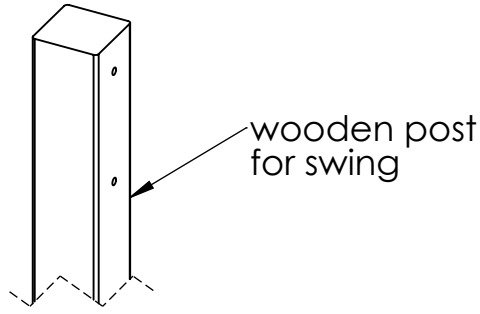

B

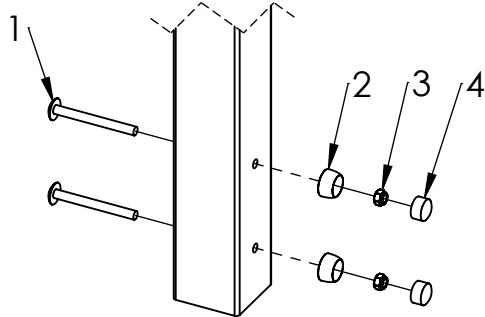

C

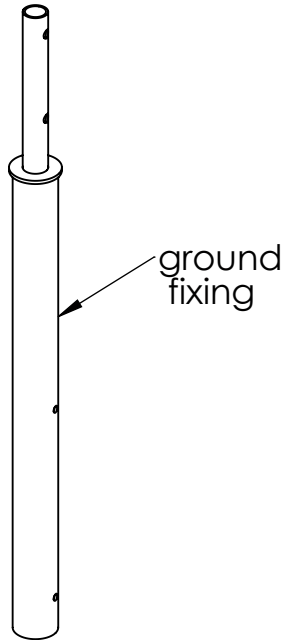

D

E

ITEM NO.	PART NUMBER
1	bolt M12x120 DIN603
2	nut cover M12
3	nut M12 DIN985
4	nut cover cap M12

UNLESS OTHERWISE SPECIFIED:
DIMENSIONS ARE IN MILLIMETERS
WEIGHT ARE IN KILOGRAMM

PART NUMBER / DWG NO.:

K010

	NAME	SIGNATURE	DATE	REVISION
DRAWN	M.Rebase		11.03.2024	
APPV'D				

DESCRIPTION:

Swing BELL-FLOWER 8 places

F



Tiptap OÜ

MATERIAL:

A4

WEIGHT:

SCALE: 1:10

SHEET 8 OF 13

A

B

C

D

E

F

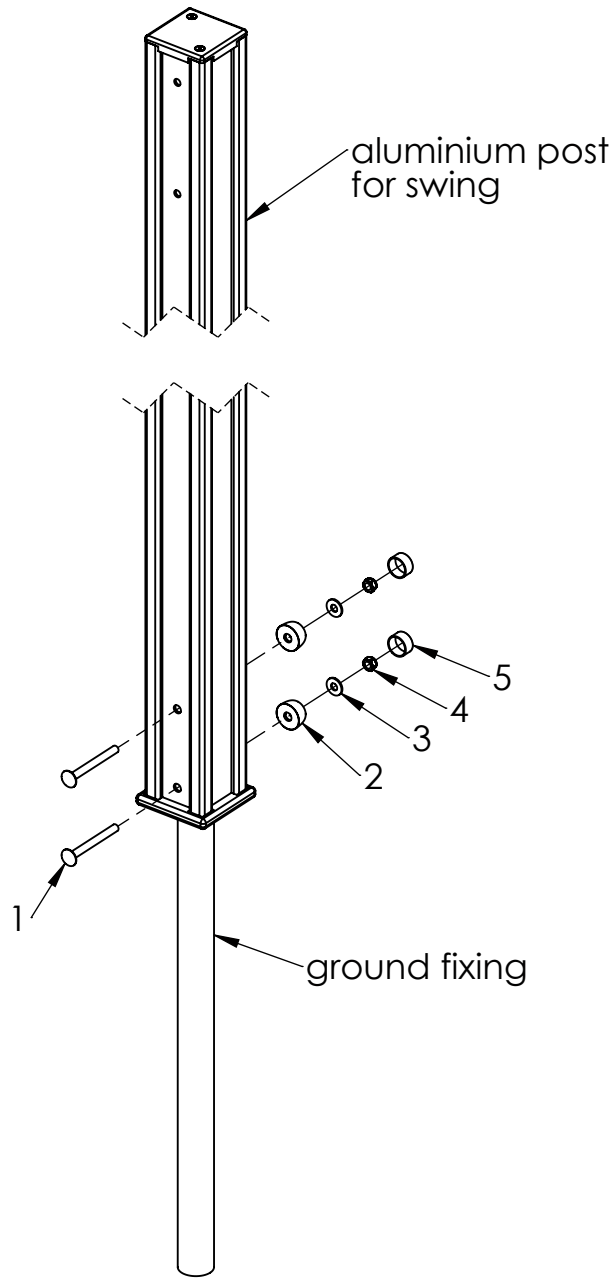

ITEM NO.	PART NUMBER
1	bolt M10x100 DIN603
2	nut cover M12
3	washer M10 DIN9054
4	nut M10 DIN985
5	nut cover cap M12

UNLESS OTHERWISE SPECIFIED:
DIMENSIONS ARE IN MILLIMETERS
WEIGHT ARE IN KILOGRAMM

NAME	SIGNATURE	DATE	REVISION
DRAWN M.Rebase		11.03.2024	
APPV'D			

PART NUMBER / DWG NO.:
K010

DESCRIPTION:
Swing BELL-FLOWER 8 places



MATERIAL:	A4
WEIGHT:	SCALE: 1:10 SHEET 9 OF 13

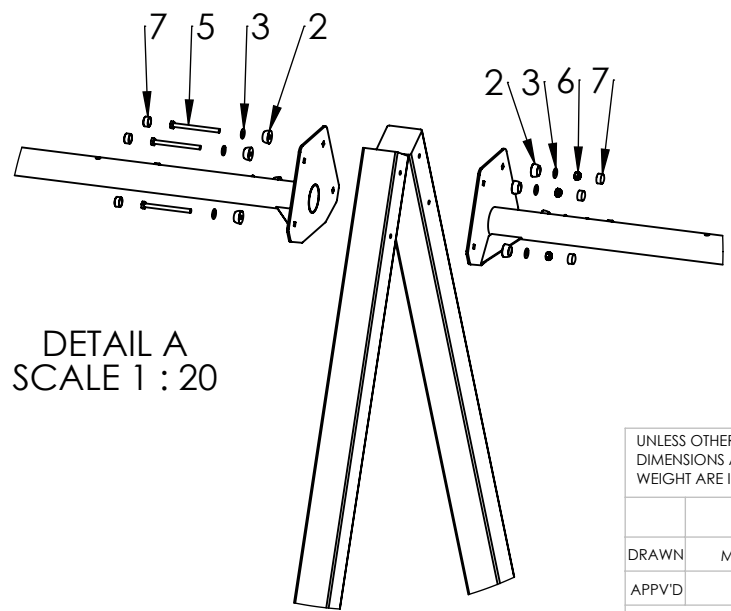
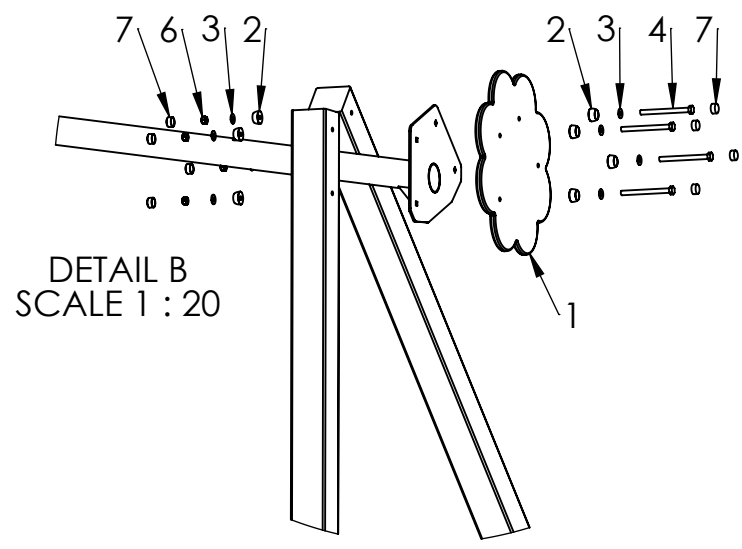
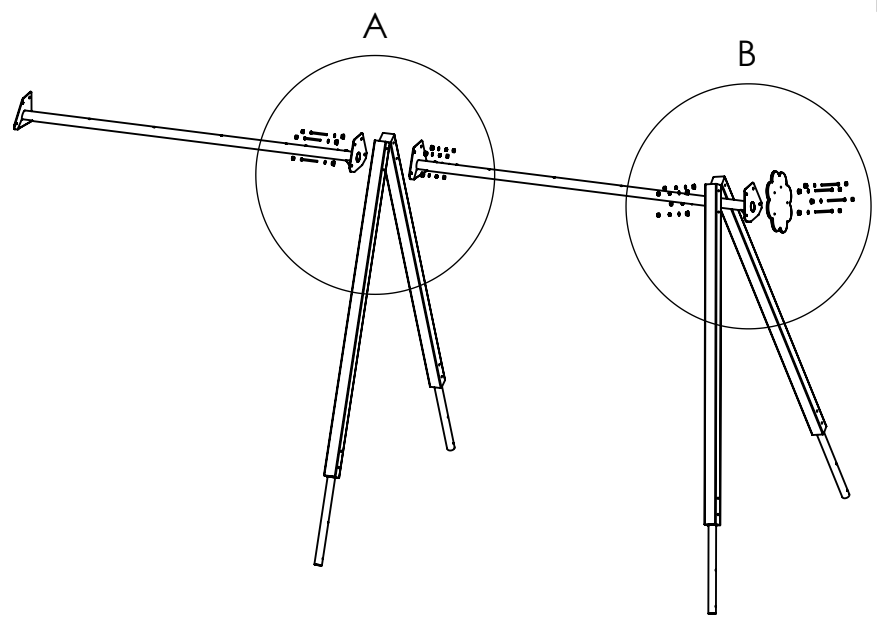

ITEM NO.	PART NUMBER
1	side fixture
2	nut cover M10
3	washer M10 DIN9054
4	for aluminium post - bolt M10x130 DIN931 for wooden post - bolt M10x140 DIN931
5	bolt M10x130 DIN931
6	nut M12 DIN985
7	nut cover cap M12

UNLESS OTHERWISE SPECIFIED:
DIMENSIONS ARE IN MILLIMETERS
WEIGHT ARE IN KILOGRAMM

	NAME	SIGNATURE	DATE	REVISION
DRAWN	M.Rebase		11.03.2024	
APPV'D				

PART NUMBER / DWG NO.:
K010

DESCRIPTION:
Swing BELL-FLOWER 8 places



MATERIAL:	A4
WEIGHT:	SCALE: 1:60 SHEET 10 OF 13

connecting seat to beam

A

B

C

D

E

F

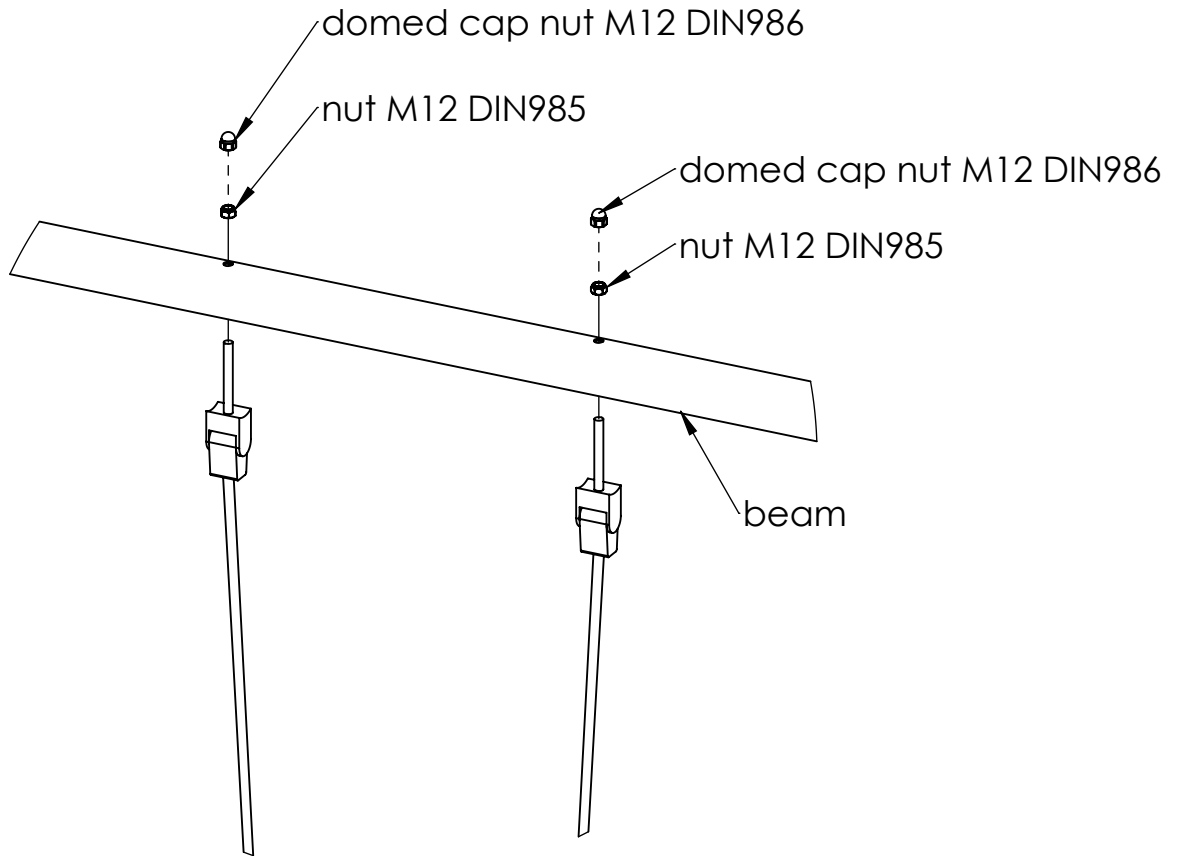

UNLESS OTHERWISE SPECIFIED:
DIMENSIONS ARE IN MILLIMETERS
WEIGHT ARE IN KILOGRAMM

PART NUMBER / DWG NO.:

K010

	NAME	SIGNATURE	DATE	REVISION
DRAWN	M.Rebase		11.03.2024	
APPV'D				

DESCRIPTION:

Swing BELL-FLOWER 8 places



Tiptiptap OÜ

MATERIAL:

A4

WEIGHT:

SCALE: 1:30

SHEET 11 OF 13

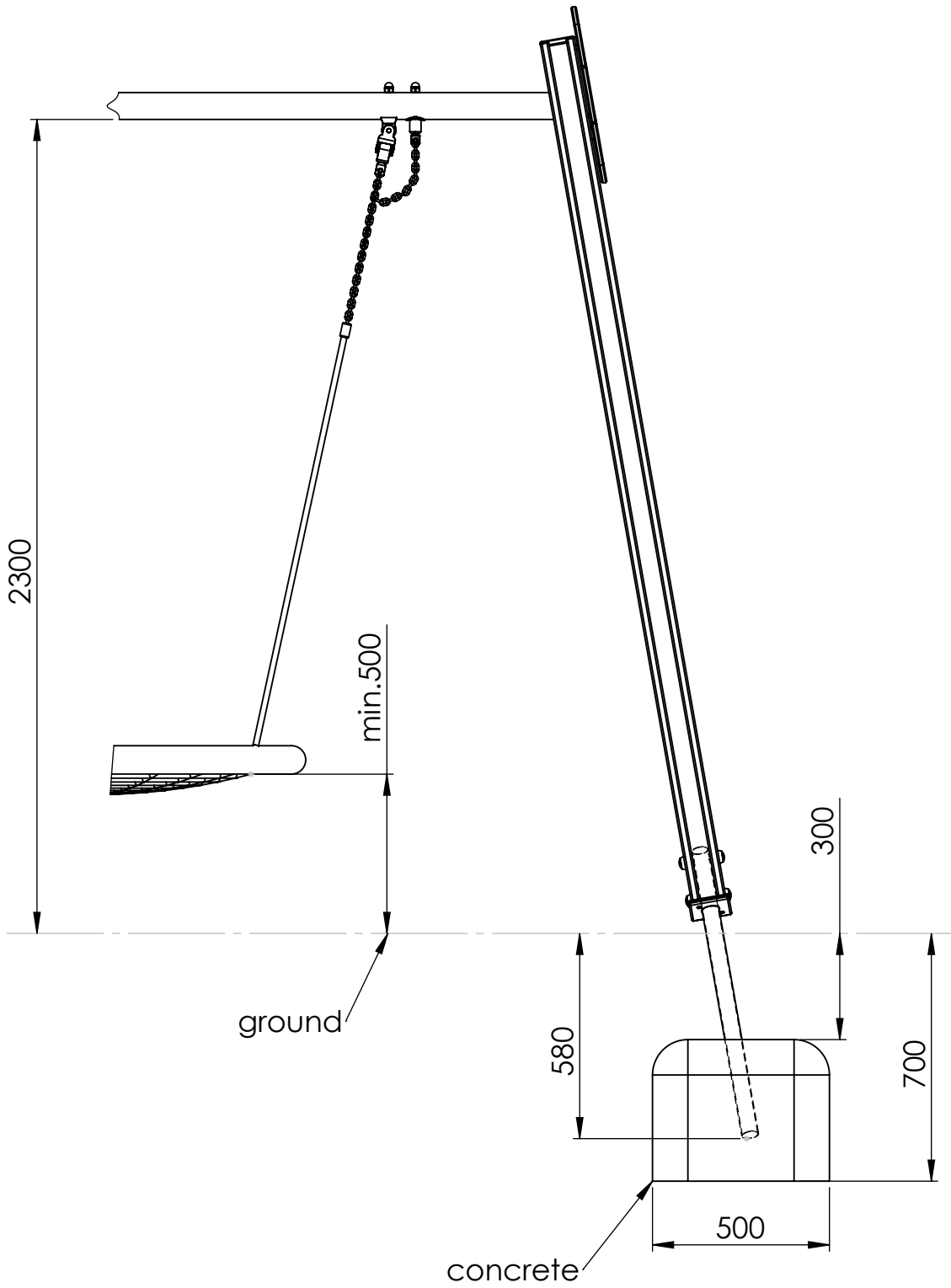

UNLESS OTHERWISE SPECIFIED:
DIMENSIONS ARE IN MILLIMETERS
WEIGHT ARE IN KILOGRAMM

PART NUMBER / DWG NO.:

K010

	NAME	SIGNATURE	DATE	REVISION
DRAWN	M.Rebase		11.03.2024	
APPV'D				

DESCRIPTION:

Swing BELL-FLOWER 8 places



Tiptap^{ÖÜ}

MATERIAL:

A4

WEIGHT:

SCALE: 1:18

SHEET 12 OF 13

A

B

C

D

E

F



DETAIL A
SCALE 1 : 5

domed cap nut M16 DIN986

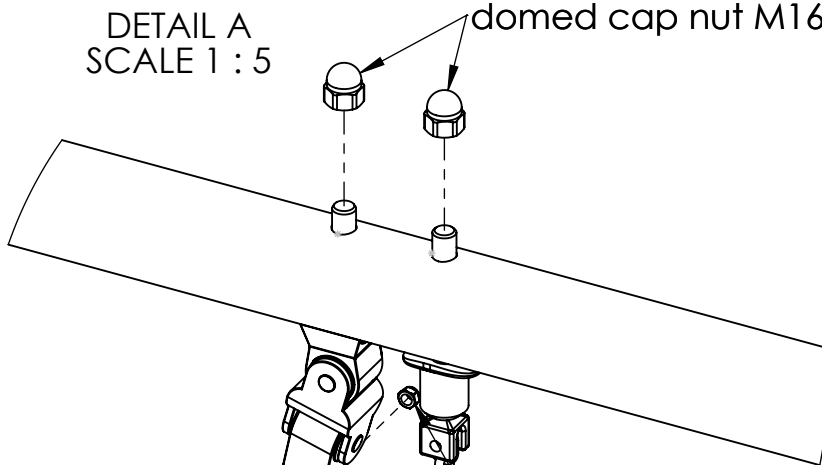

bolt M8x35 DIN933

nut M8 DIN985

shackle pin

safety chain for birdnest

shackle

UNLESS OTHERWISE SPECIFIED:
DIMENSIONS ARE IN MILLIMETERS
WEIGHT ARE IN KILOGRAMM

PART NUMBER / DWG NO.:

K010

	NAME	SIGNATURE	DATE	REVISION
DRAWN	M.Rebase		11.03.2024	
APPV'D				

DESCRIPTION:

Swing BELL-FLOWER 8 places

MATERIAL:

A4

WEIGHT:

SCALE: 1:35

SHEET 13 OF 13



Tiptiptap^{ÖÜ}