

A

B

C

D

E

F

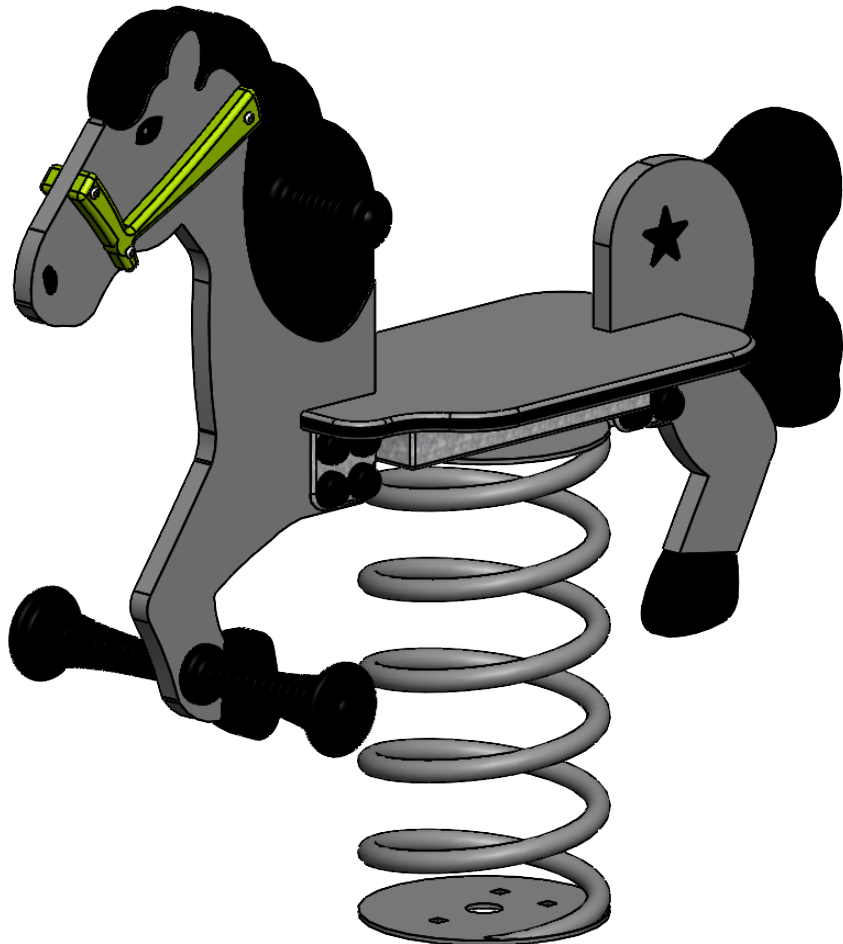

UNLESS OTHERWISE SPECIFIED:
 DIMENSIONS ARE IN MILLIMETERS
 WEIGHT ARE IN KILOGRAMM

PART NUMBER / DWG NO.:
VLO52

	NAME	SIGNATURE	DATE	REVISION
DRAWN	E.Reispere		18.08.2023	
APPV'D				

DESCRIPTION:
Spring swing HORSE



MATERIAL: metal, plastic A4

WEIGHT: SCALE: 1:10 SHEET 1 OF 10

safety area

A

B

C

D

E

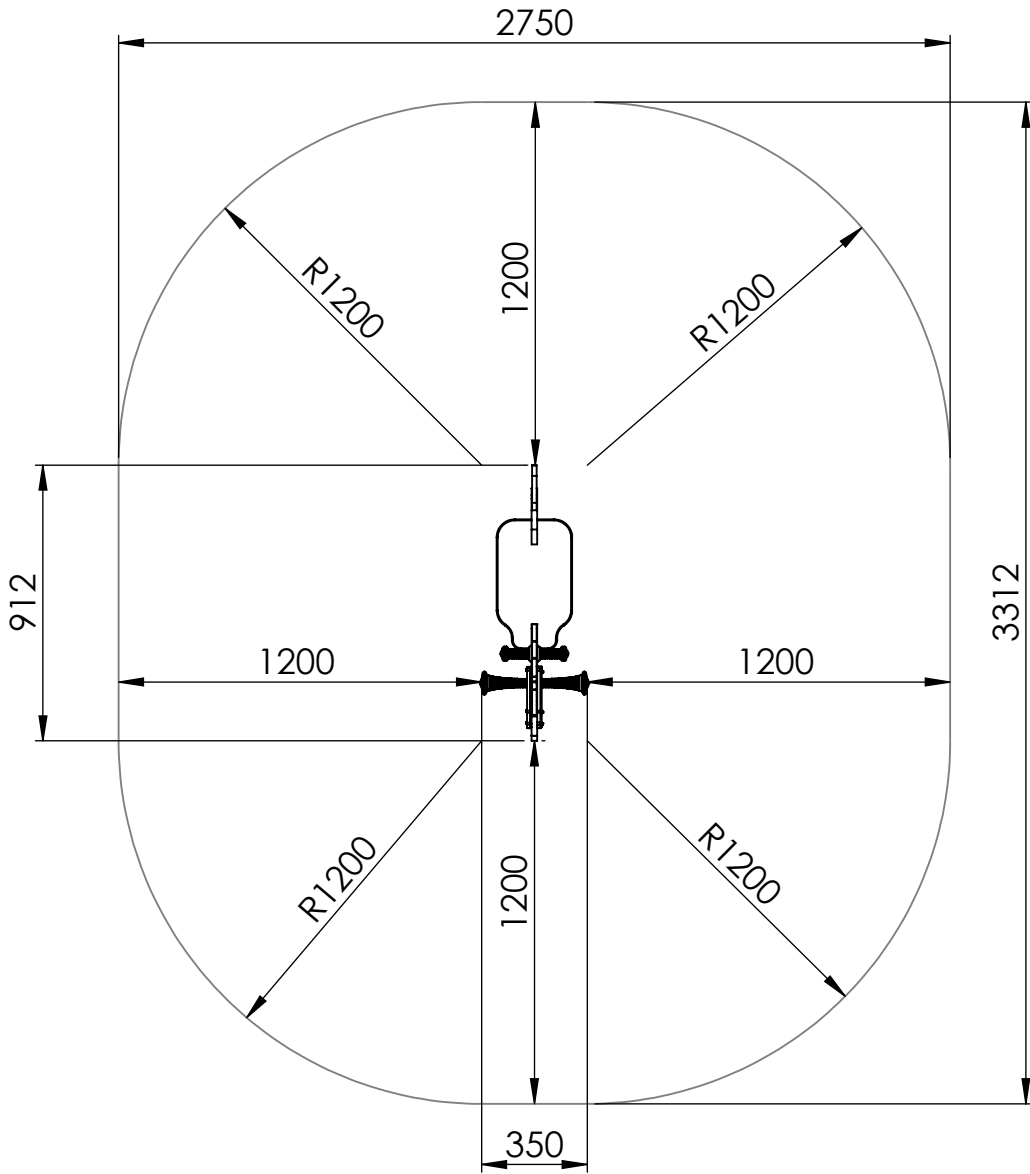

safety area: 7,87 m²

UNLESS OTHERWISE SPECIFIED:
DIMENSIONS ARE IN MILLIMETERS
WEIGHT ARE IN KILOGRAMM

PART NUMBER / DWG NO.:

VLO52

	NAME	SIGNATURE	DATE	REVISION
DRAWN	E.Reispere		18.08.2023	
APPV'D				

DESCRIPTION:

Spring swing HORSE

MATERIAL:

metal, plastic

A4

WEIGHT:

SCALE: 1:10

SHEET 2 OF 10



Tiptiptap ⁰⁰

foundation

A

B

C

D

E

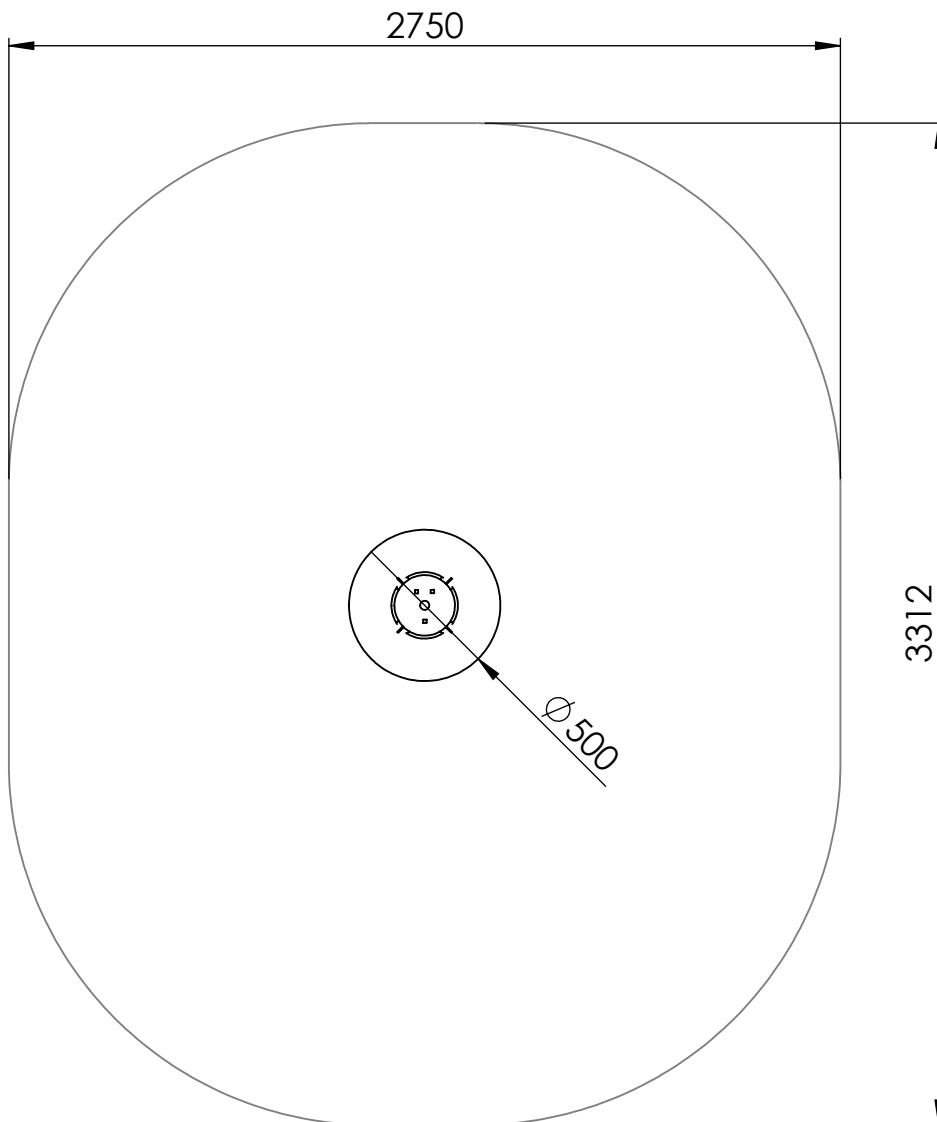

UNLESS OTHERWISE SPECIFIED:
 DIMENSIONS ARE IN MILLIMETERS
 WEIGHT ARE IN KILOGRAMM

PART NUMBER / DWG NO.: **VLO52**

	NAME	SIGNATURE	DATE	REVISION
DRAWN	E.Reispere		18.08.2023	
APPV'D				

DESCRIPTION:
Spring swing HORSE



MATERIAL: **metal, plastic** A4

WEIGHT: SCALE: 1:10 SHEET 3 OF 10

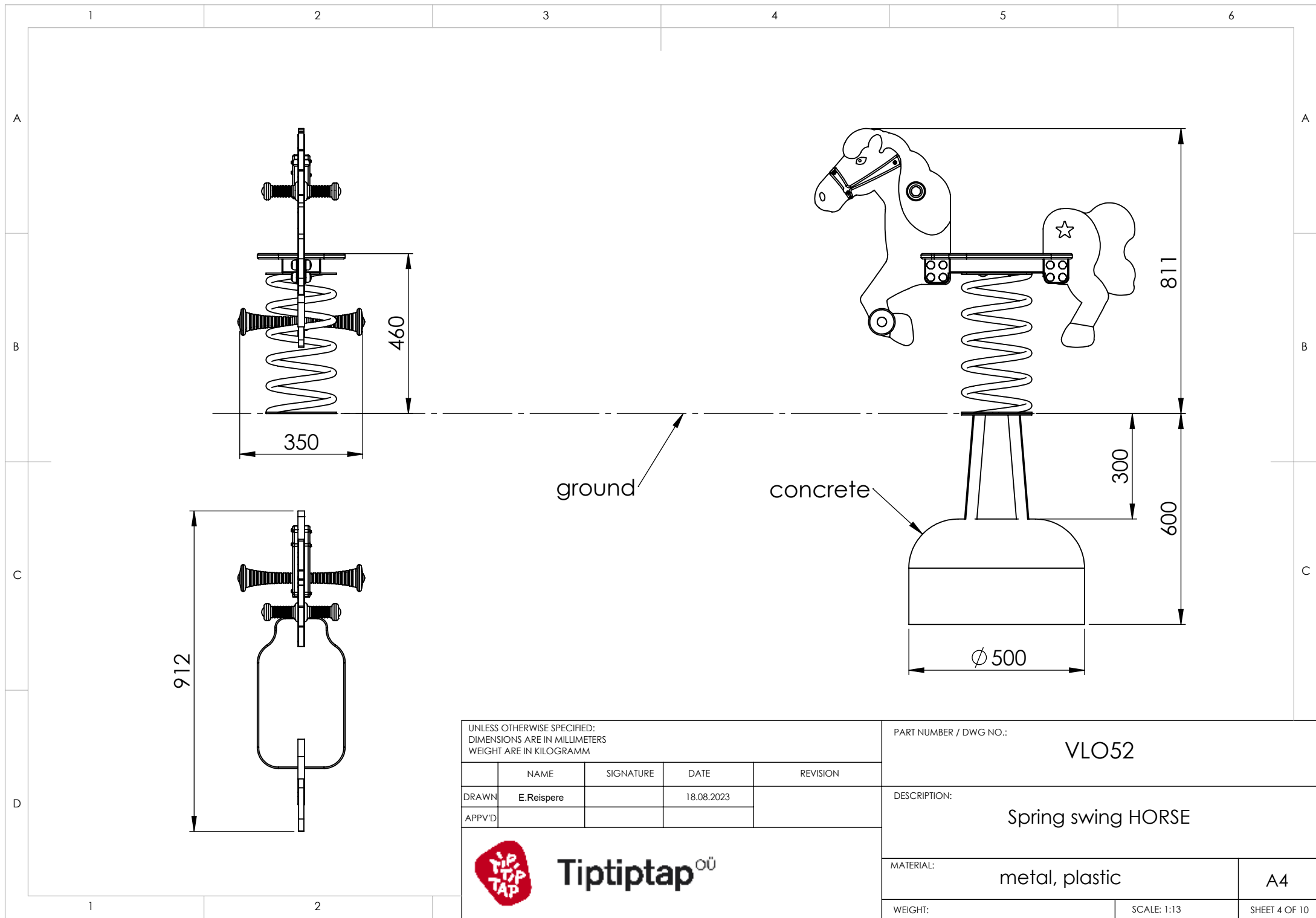

UNLESS OTHERWISE SPECIFIED:
 DIMENSIONS ARE IN MILLIMETERS
 WEIGHT ARE IN KILOGRAMM

PART NUMBER / DWG NO.:
VLO52

	NAME	SIGNATURE	DATE	REVISION
DRAWN	E.Reispere		18.08.2023	
APPV'D				

DESCRIPTION:
Spring swing HORSE



MATERIAL:	metal, plastic	A4
WEIGHT:		SCALE: 1:13
		SHEET 4 OF 10

A

B

C

D

E

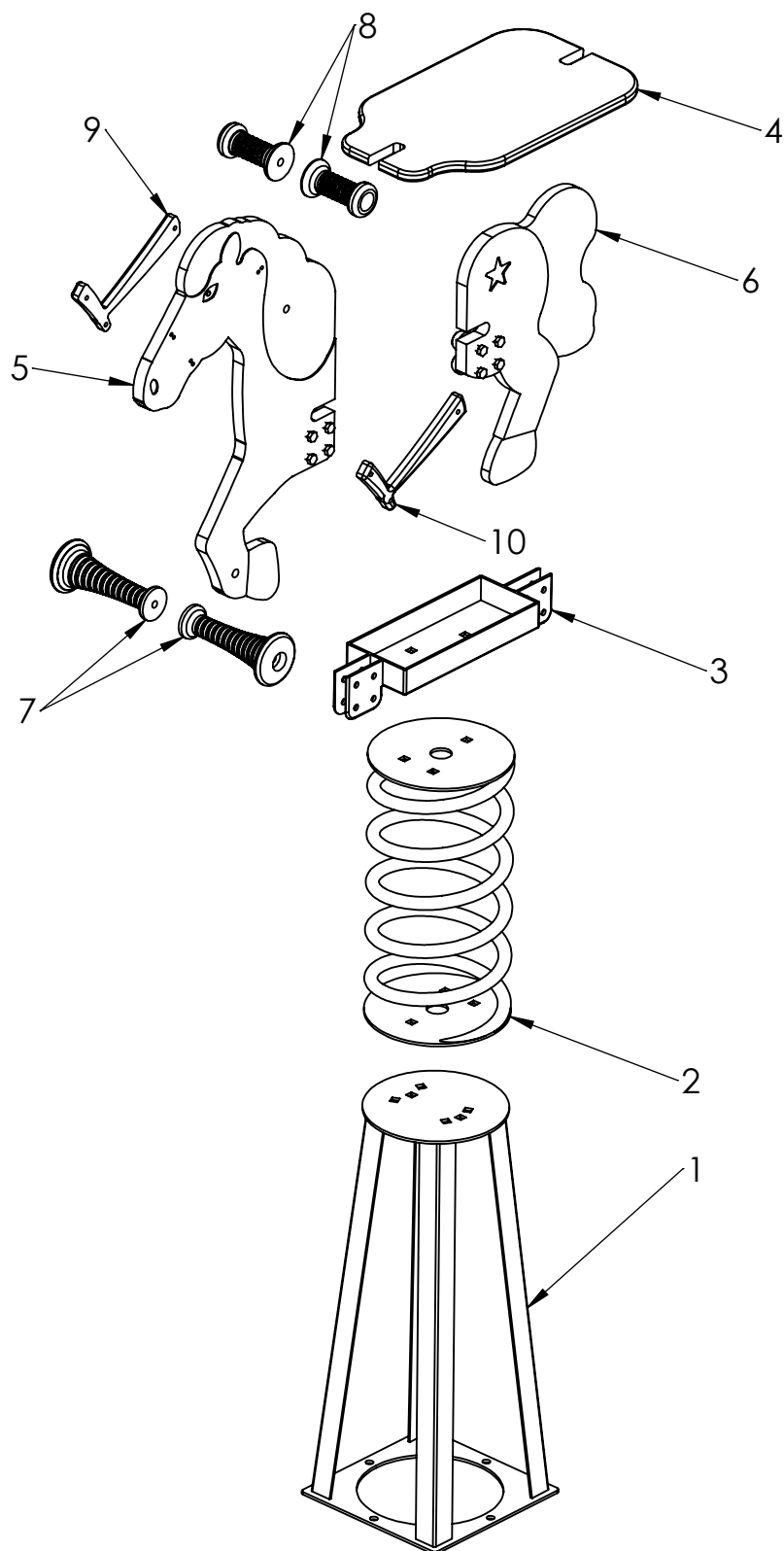

ITEM NO.	PART NUMBER
1	ground fixing
2	spring with spring disk
3	central console
4	seat for spring swing
5	VLO52 head panel
6	VLO52 tail panel
7	leg support n
8	handle n
9	VLO52 halter R
10	VLO52 halter L

UNLESS OTHERWISE SPECIFIED:
DIMENSIONS ARE IN MILLIMETERS
WEIGHT ARE IN KILOGRAMM

PART NUMBER / DWG NO.:

VLO52

	NAME	SIGNATURE	DATE	REVISION
DRAWN	E.Reispere		18.08.2023	
APPV'D				

DESCRIPTION:

Spring swing HORSE

MATERIAL:

metal, plastic

A4

WEIGHT:

SCALE: 1:13

SHEET 5 OF 10



Tiptiptap OÜ

A

B

C

D

E

F

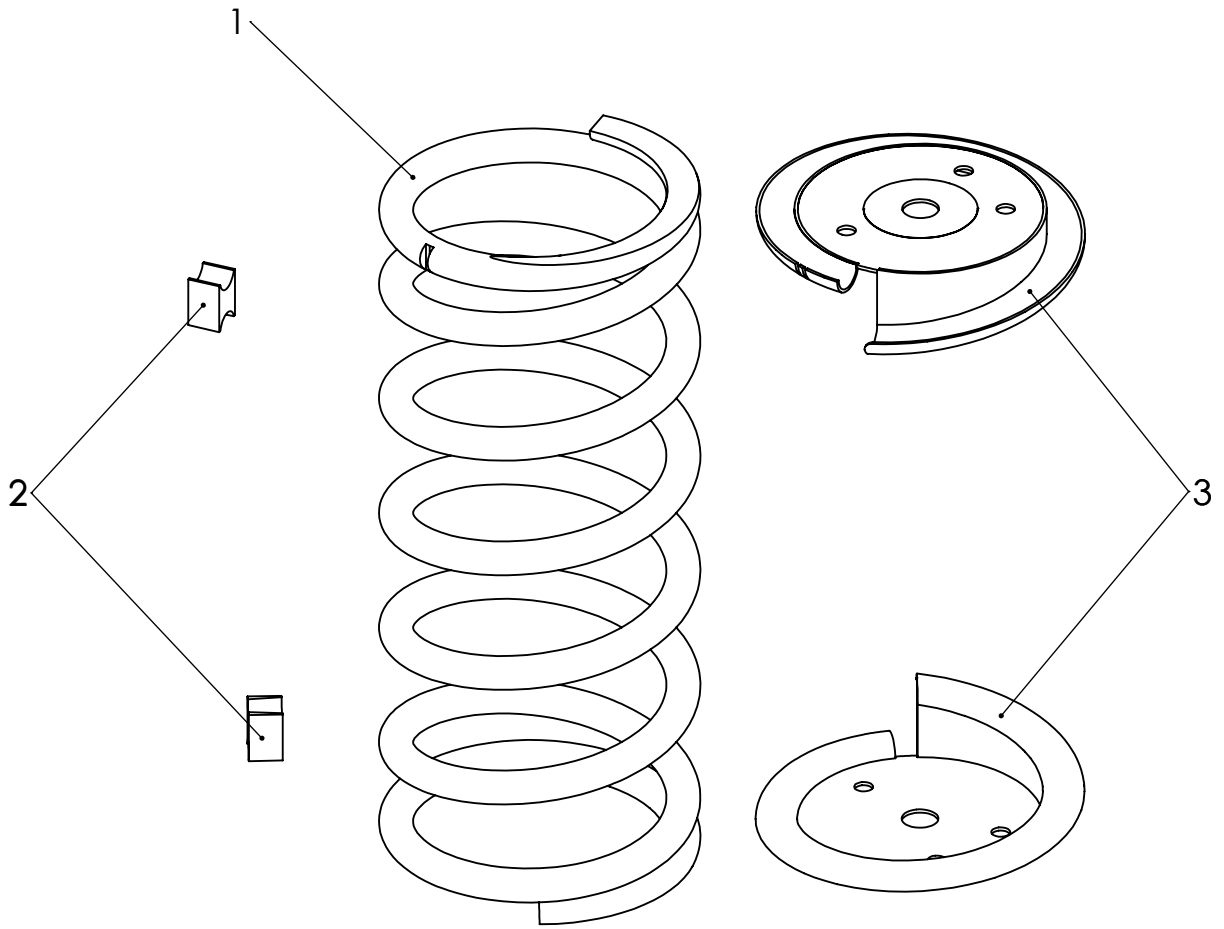

ITEM NO.	PART NUMBER	QTY.
1	spring	1
2	distance block	2
3	spring plate	2

UNLESS OTHERWISE SPECIFIED:
 DIMENSIONS ARE IN MILLIMETERS
 WEIGHT ARE IN KILOGRAMM

PART NUMBER / DWG NO.:

VLO52

	NAME	SIGNATURE	DATE	REVISION
DRAWN	E.Reispere		18.08.2023	
APPV'D				

DESCRIPTION:

Spring swing HORSE

MATERIAL:

metal, plastic

A4

WEIGHT:

SCALE: 1:4

SHEET 6 OF 10



Tiptiptap ^{OO}

view 2

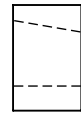
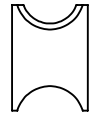
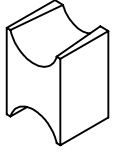

view 1

A

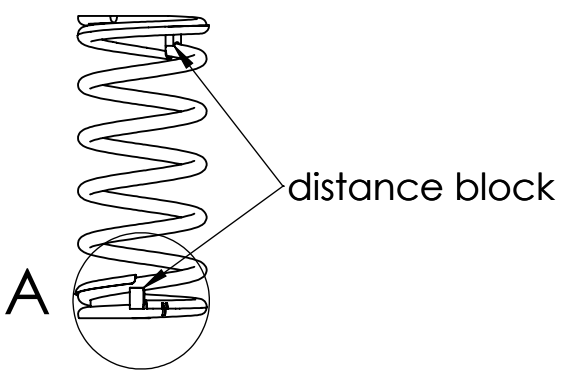

B

DETAIL A

C

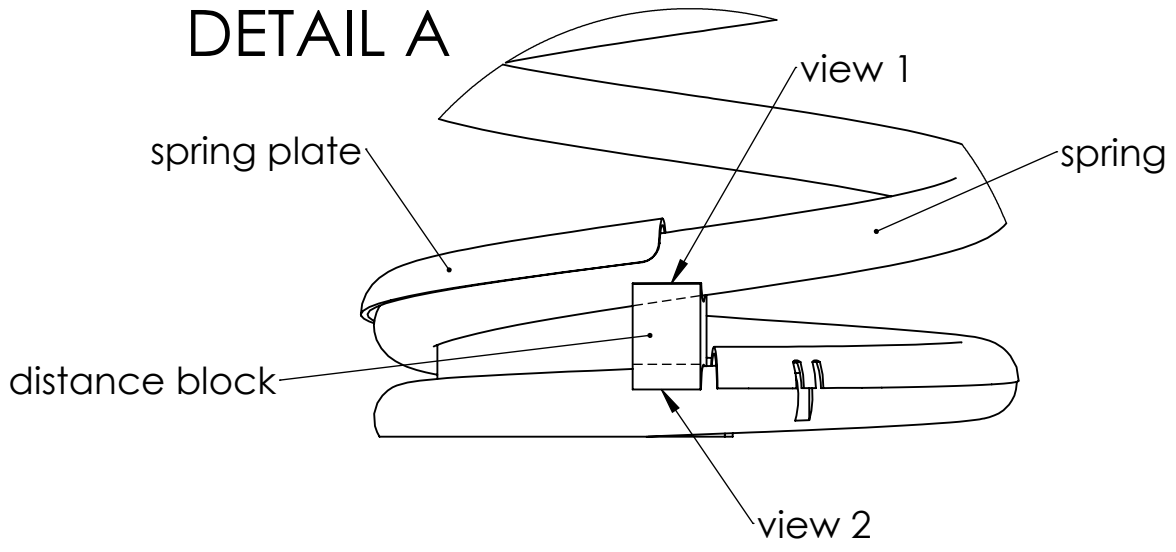

D

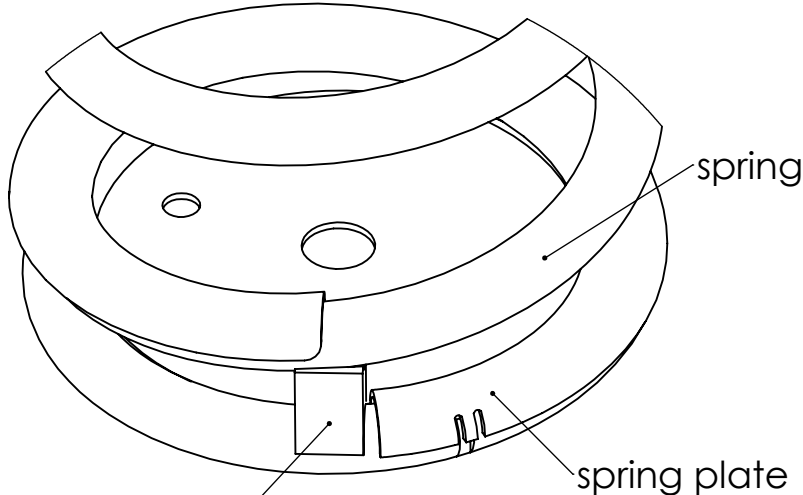

E

F

UNLESS OTHERWISE SPECIFIED: DIMENSIONS ARE IN MILLIMETERS WEIGHT ARE IN KILOGRAMM				
	NAME	SIGNATURE	DATE	REVISION
DRAWN	E.Reispere		18.08.2023	
APPV'D				

PART NUMBER / DWG NO.:	VLO52
DESCRIPTION:	Spring swing HORSE



MATERIAL:	metal, plastic	A4
WEIGHT:	SCALE: 1:4	SHEET 7 OF 10

A

B

C

D

E

F

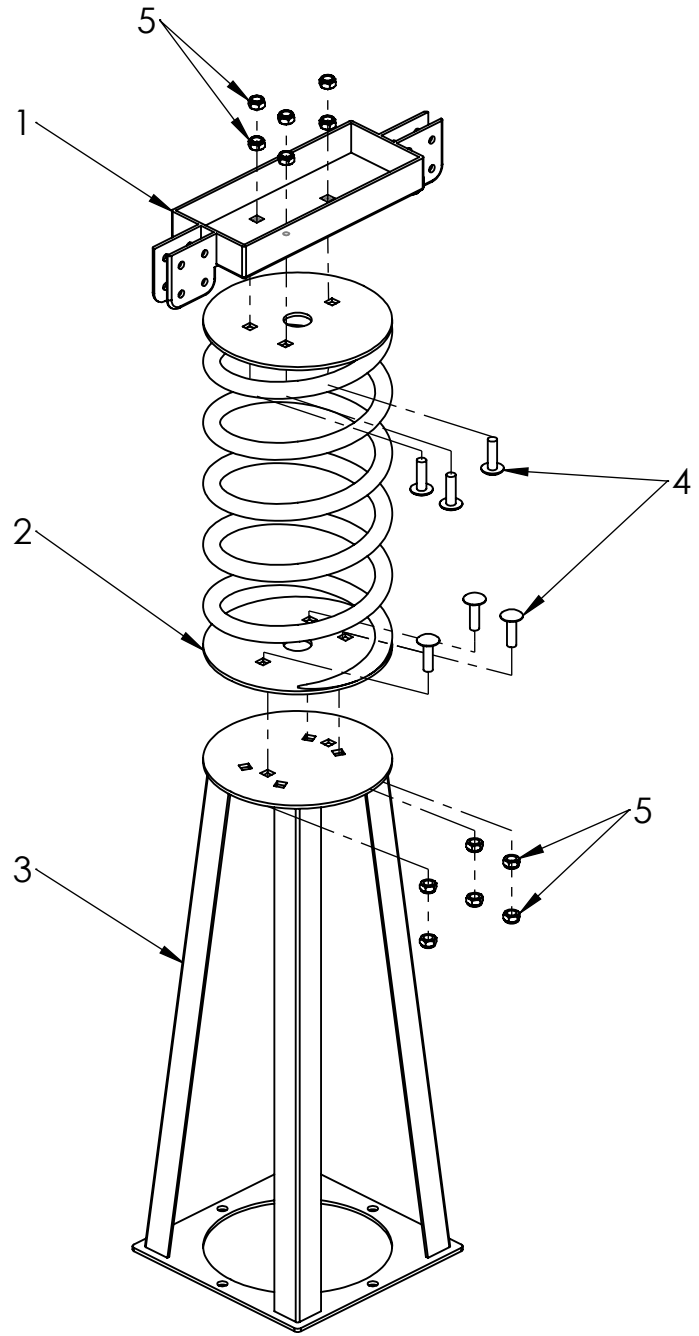

ITEM NO.	PART NUMBER
1	central console
2	spring with spring disk
3	ground fixing
4	bolt DIN603 M10x35
5	nut DIN985 M10

UNLESS OTHERWISE SPECIFIED: DIMENSIONS ARE IN MILLIMETERS WEIGHT ARE IN KILOGRAMM				
	NAME	SIGNATURE	DATE	REVISION
DRAWN	E.Reispere		18.08.2023	
APPV'D				

PART NUMBER / DWG NO.:	VLO52
DESCRIPTION:	Spring swing HORSE



MATERIAL:	metal, plastic	A4
WEIGHT:		SCALE: 1:10
		SHEET 8 OF 10

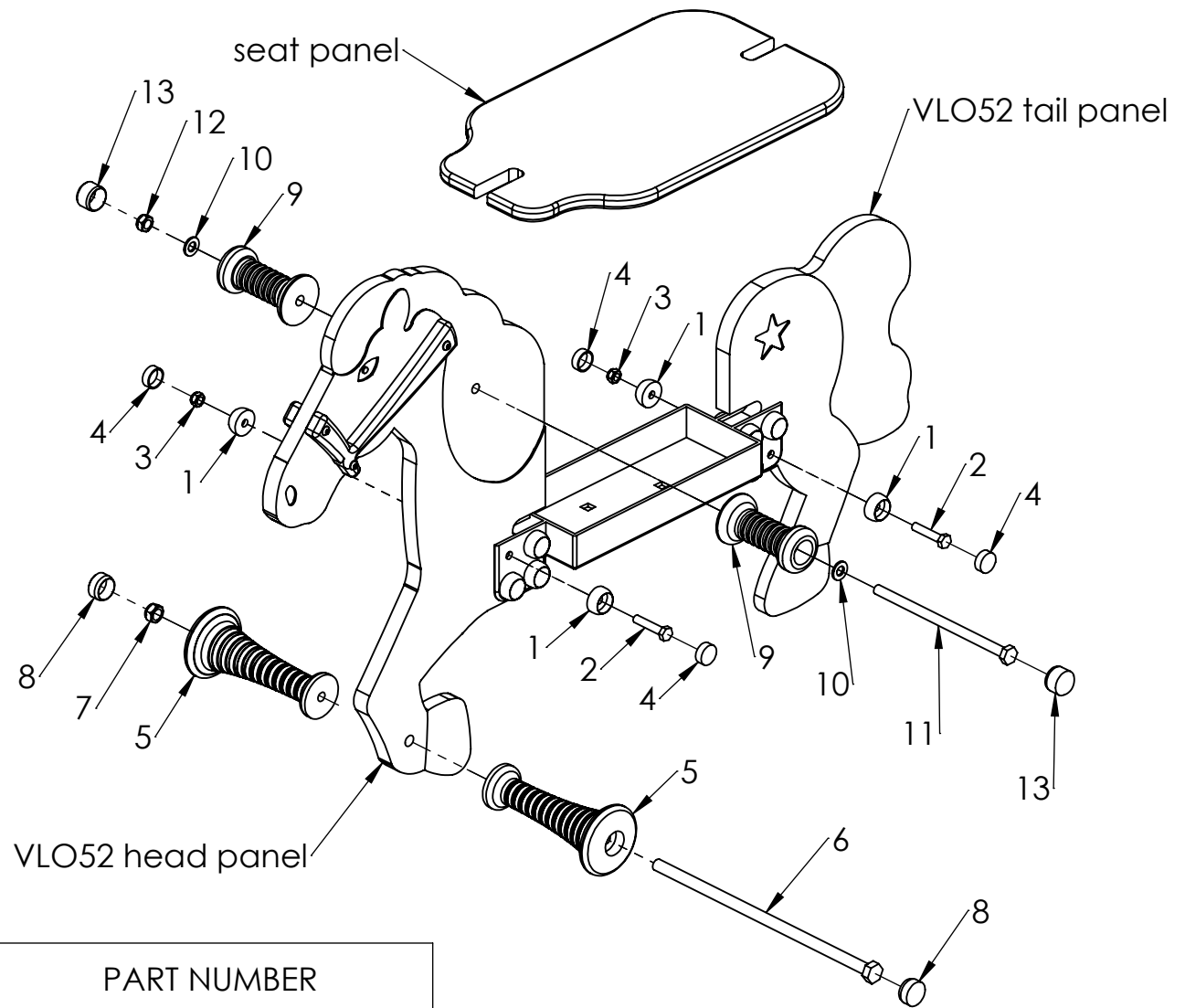

ITEM NO.	PART NUMBER
1	nut cover M8
2	bolt DIN933 M8x40
3	nut DIN985 M8
4	nut cover cap M8
5	leg support n
6	bolt M12x305 DIN931
7	nut DIN985 M12
8	leg support new cover cup
9	handle n
10	washer M10 DIN125
11	bolt M10x185 DIN931
12	nut DIN985 M10
13	handle new cup

UNLESS OTHERWISE SPECIFIED: DIMENSIONS ARE IN MILLIMETERS WEIGHT ARE IN KILOGRAMM				
	NAME	SIGNATURE	DATE	REVISION
DRAWN	E.Reispere		18.08.2023	
APPV'D				

PART NUMBER / DWG NO.:		VLO52	
DESCRIPTION:			
Spring swing HORSE			
MATERIAL:		metal, plastic	A4
WEIGHT:		SCALE: 1:4	SHEET 9 OF 10



Tiptiptap OÜ

A

B

C

D

E

F

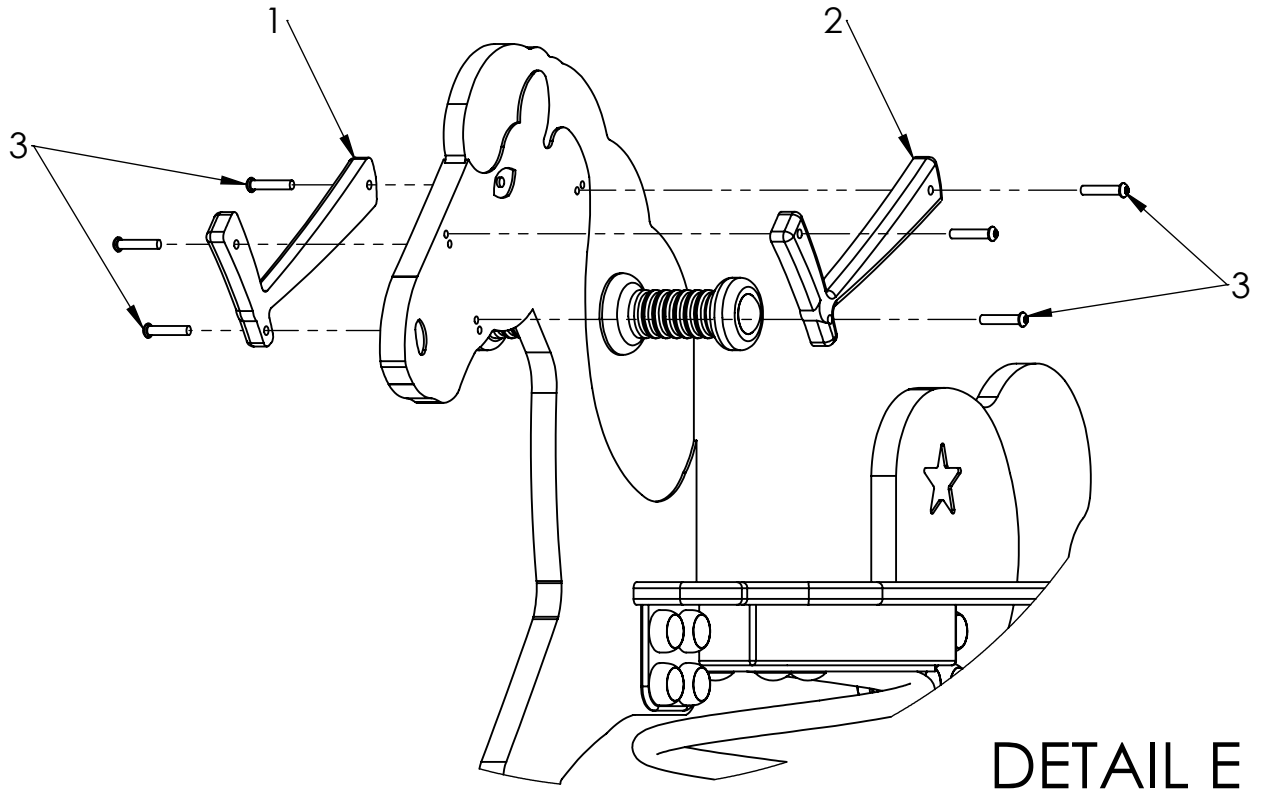

DETAIL E

E

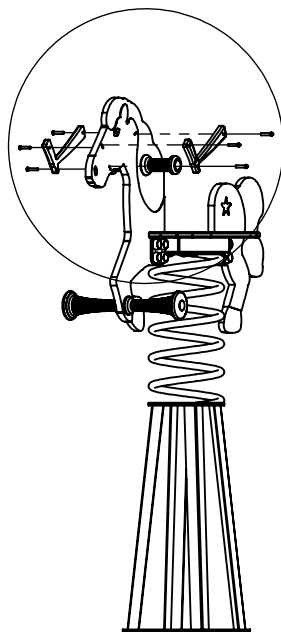

ITEM NO.	PART NUMBER
1	VLO52 halter R
2	VLO52 halter L
3	bolt M6x30 DIN7380

UNLESS OTHERWISE SPECIFIED:
 DIMENSIONS ARE IN MILLIMETERS
 WEIGHT ARE IN KILOGRAMM

PART NUMBER / DWG NO.:

VLO52

	NAME	SIGNATURE	DATE	REVISION
DRAWN	E.Reispere		18.08.2023	
APPV'D				

DESCRIPTION:

Spring swing HORSE

MATERIAL:

metal, plastic

A4

WEIGHT:

SCALE: 1:4

SHEET 10 OF 10



Tiptiptap OÜ