

A

B

C

D

E

F

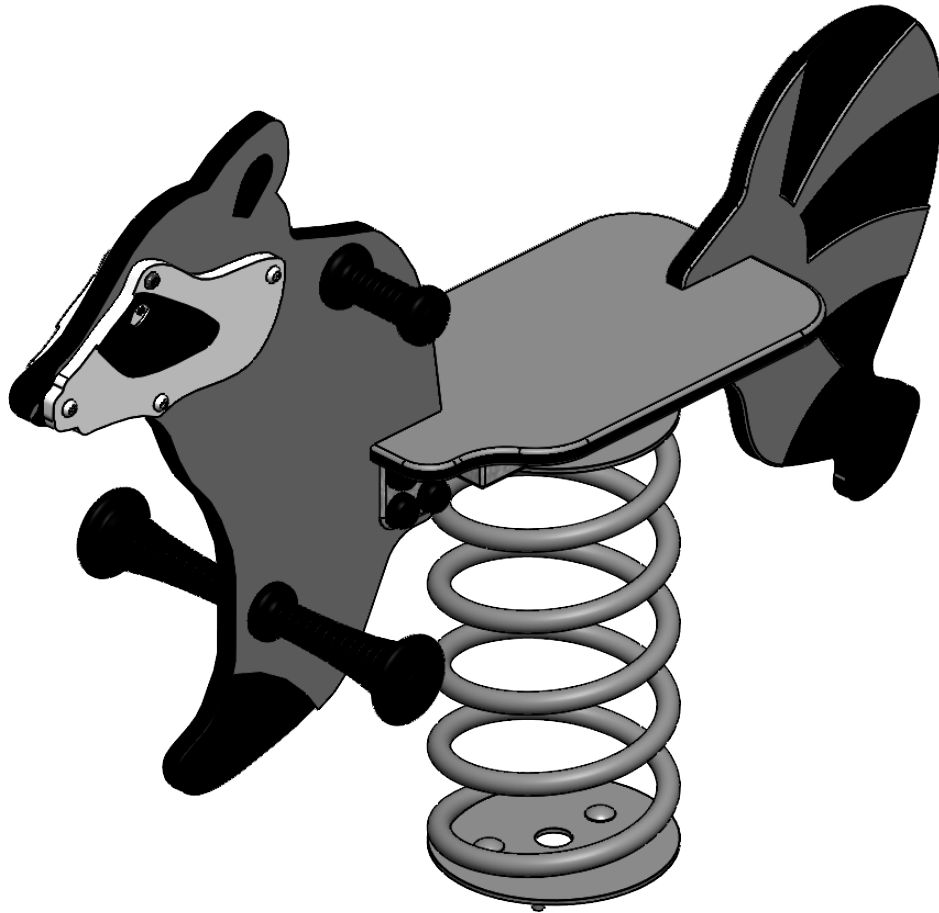

UNLESS OTHERWISE SPECIFIED:
 DIMENSIONS ARE IN MILLIMETERS
 WEIGHT ARE IN KILOGRAMM

PART NUMBER / DWG NO.:

VL55

	NAME	SIGNATURE	DATE	REVISION
DRAWN	E.Reispere		30.01.2025	
APPV'D				

DESCRIPTION:

Spring swing RACOON



Tiptiptap⁰⁰

MATERIAL:

metal, plastic

A4

WEIGHT:

SCALE: 1:20

SHEET 1 OF 10

safety area

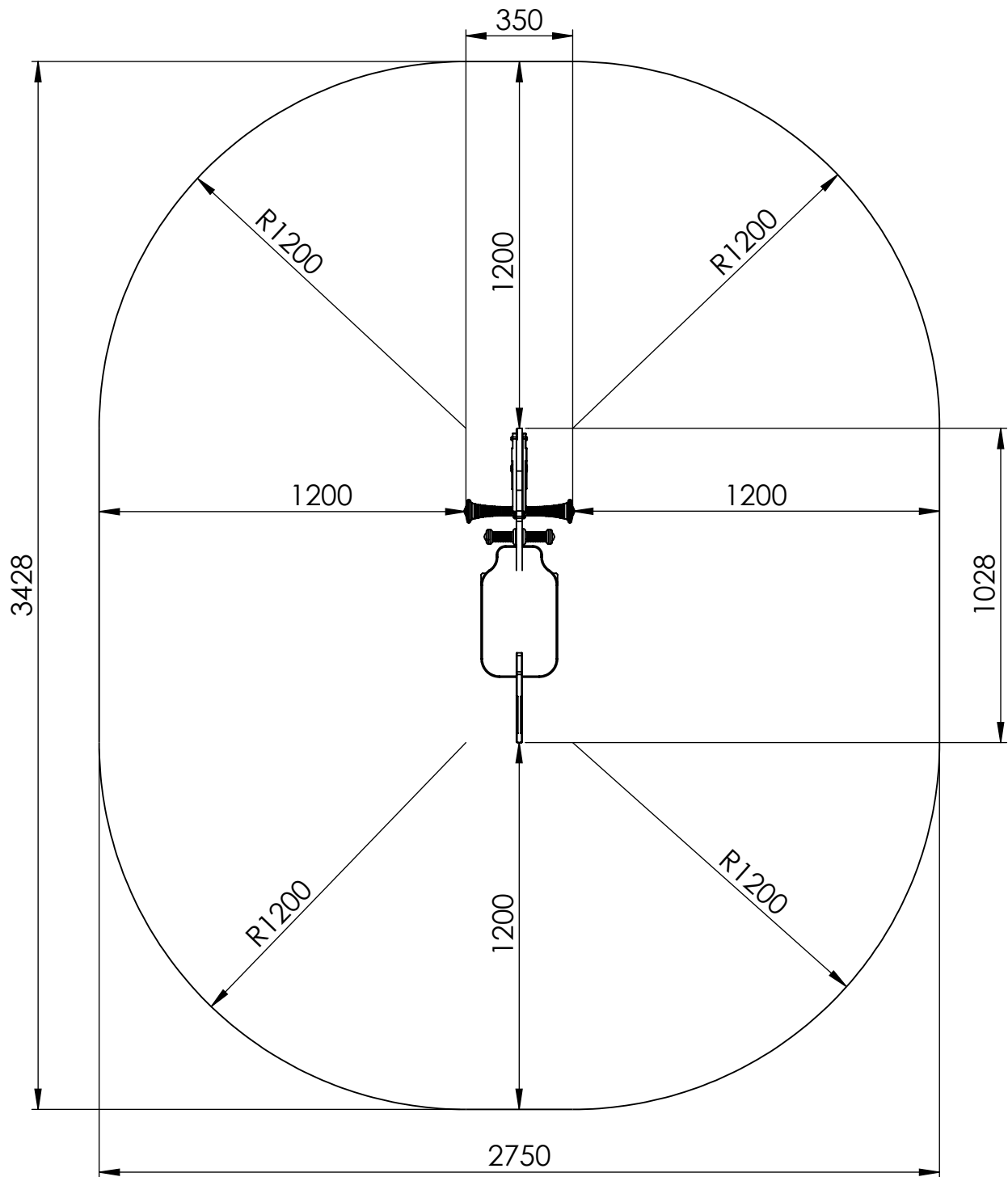

UNLESS OTHERWISE SPECIFIED:
DIMENSIONS ARE IN MILLIMETERS
WEIGHT ARE IN KILOGRAMM

PART NUMBER / DWG NO.:

VL55

	NAME	SIGNATURE	DATE	REVISION
DRAWN	E.Reispere		30.01.2025	
APPV'D				

DESCRIPTION:

Spring swing RACOON

MATERIAL:

metal, plastic

A4

WEIGHT:

SCALE: 1:20

SHEET 2 OF 10



Tiptiptap^{OO}

foundation

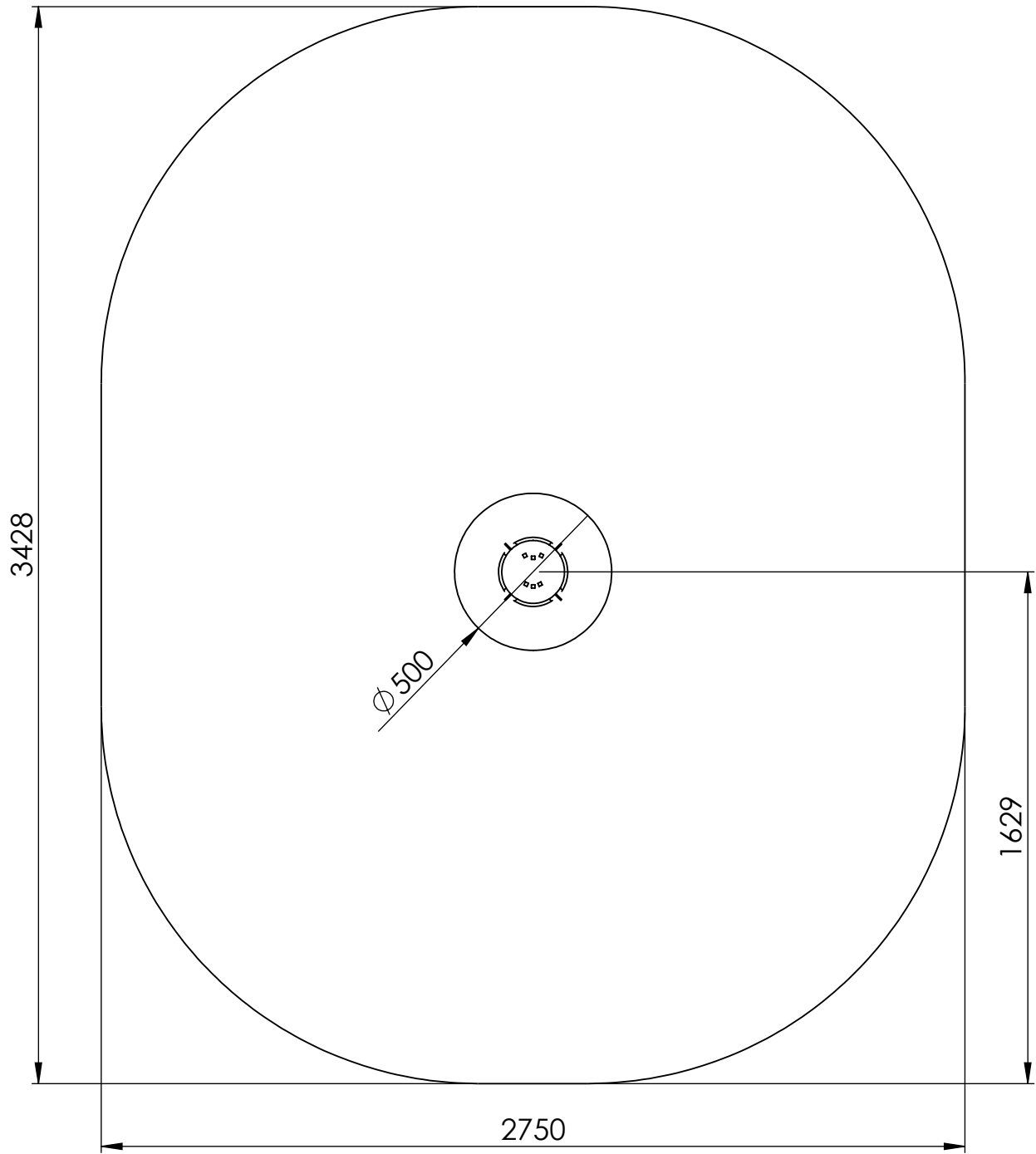

UNLESS OTHERWISE SPECIFIED:
DIMENSIONS ARE IN MILLIMETERS
WEIGHT ARE IN KILOGRAMM

PART NUMBER / DWG NO.:

VL55

	NAME	SIGNATURE	DATE	REVISION
DRAWN	E.Reispere		30.01.2025	
APPV'D				

DESCRIPTION:

Spring swing RACOON



Tiptiptap ^{ÖÜ}

MATERIAL:

metal, plastic

A4

WEIGHT:

SCALE: 1:20

SHEET 3 OF 10

A

B

C

D

E

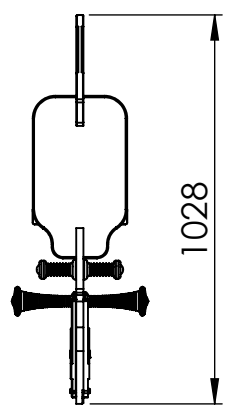
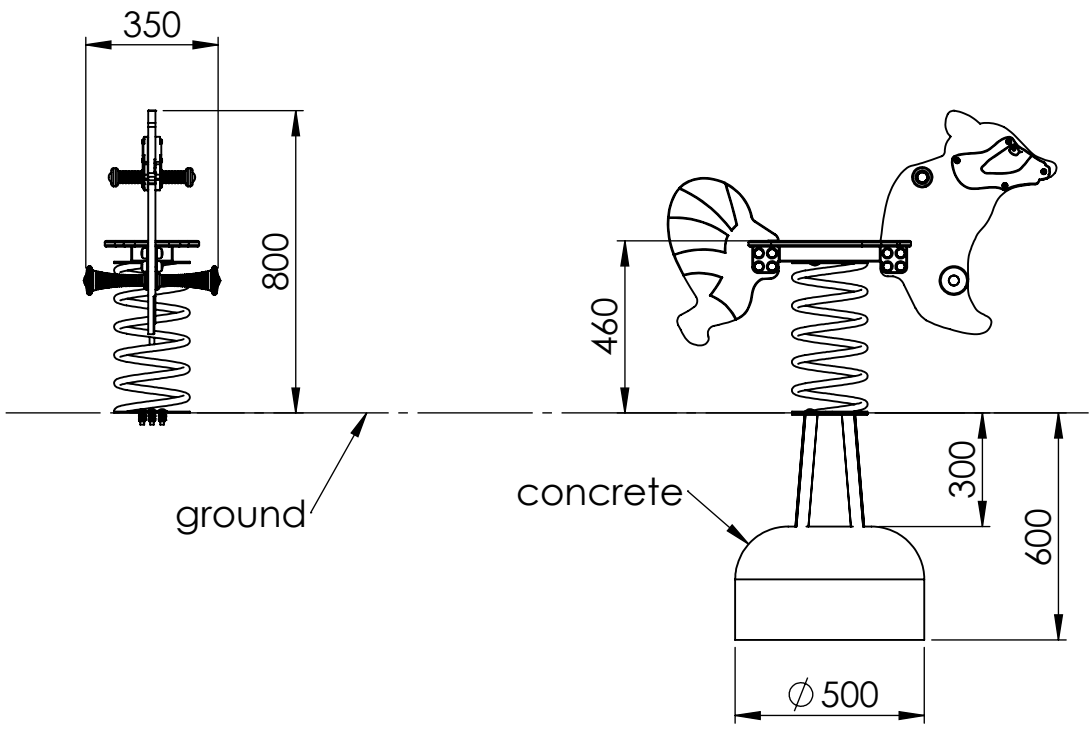

UNLESS OTHERWISE SPECIFIED:
 DIMENSIONS ARE IN MILLIMETERS
 WEIGHT ARE IN KILOGRAMM

PART NUMBER / DWG NO.:
VL55

	NAME	SIGNATURE	DATE	REVISION
DRAWN	E.Reispere		30.01.2025	
APPV'D				

DESCRIPTION:
Spring swing RACOON



MATERIAL: metal, plastic A4

WEIGHT: SCALE: 1:20 SHEET 4 OF 10

A

B

C

D

E

F

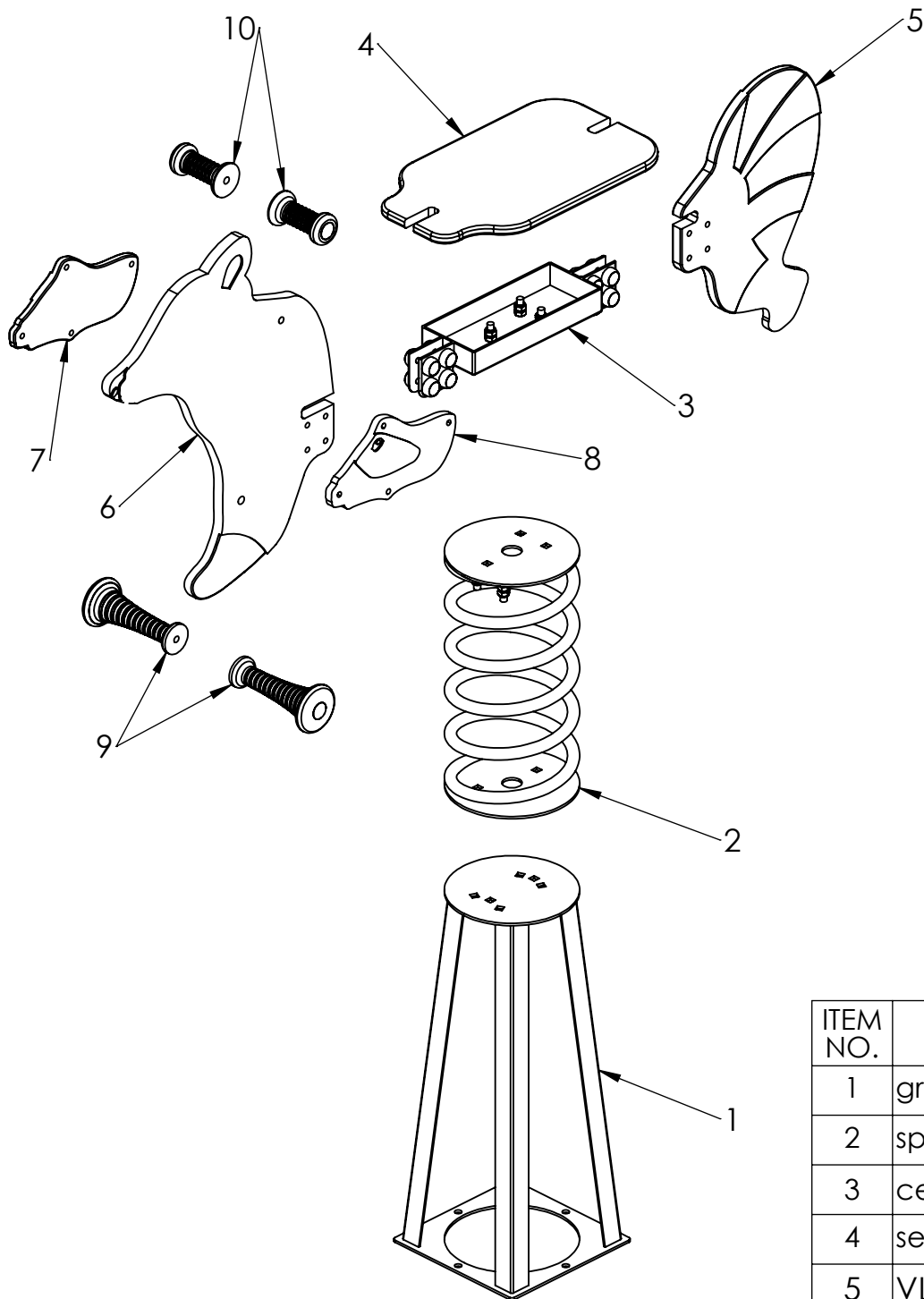

ITEM NO.	PART NUMBER
1	ground fixing
2	spring with spring disk
3	central console
4	seat for spring swing
5	VL55 tail
6	VL55 body panel
7	VL55 face panel 1
8	VL55 face panel 2
9	leg support n
10	handle new

UNLESS OTHERWISE SPECIFIED:
DIMENSIONS ARE IN MILLIMETERS
WEIGHT ARE IN KILOGRAMM

PART NUMBER / DWG NO.:

VL55

	NAME	SIGNATURE	DATE	REVISION
DRAWN	E.Reispere		30.01.2025	
APPV'D				

DESCRIPTION:

Spring swing RACOON

MATERIAL:

metal, plastic

A4

WEIGHT:

SCALE: 1:20

SHEET 5 OF 10



Tiptap ^{OO}

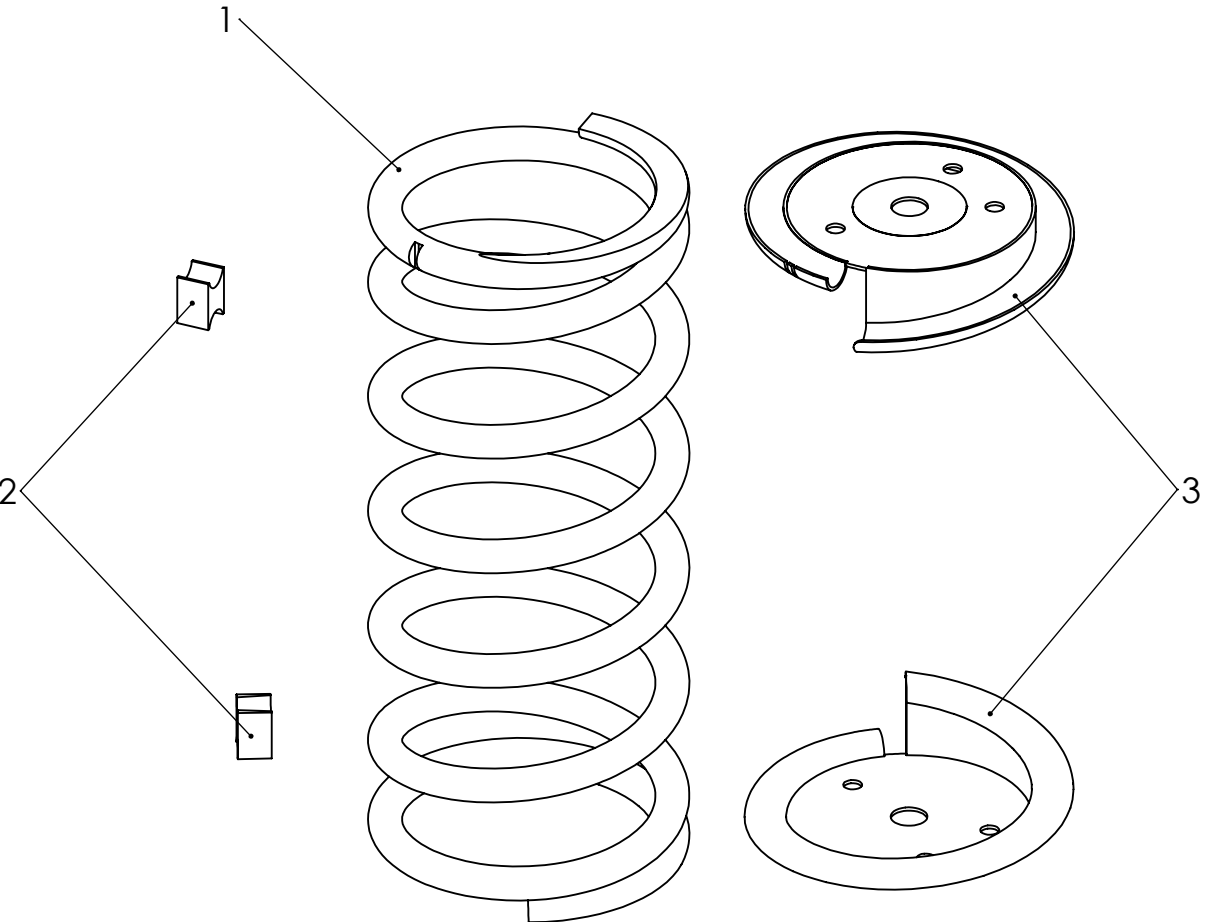

ITEM NO.	PART NUMBER	DESCRIPTION	QTY.
1	spring	painted steel	1
2	distance block	HP plastic	2
3	spring plate	painted steel	2

UNLESS OTHERWISE SPECIFIED:
 DIMENSIONS ARE IN MILLIMETERS
 WEIGHT ARE IN KILOGRAMM

PART NUMBER / DWG NO.:
VL55

	NAME	SIGNATURE	DATE	REVISION
DRAWN	E.Reispere		30.01.2025	
APPV'D				

DESCRIPTION:
Spring swing RACOON



MATERIAL:	metal, plastic	A4
WEIGHT:		SCALE: 1:4
		SHEET 6 OF 10

1

2

3

4

A

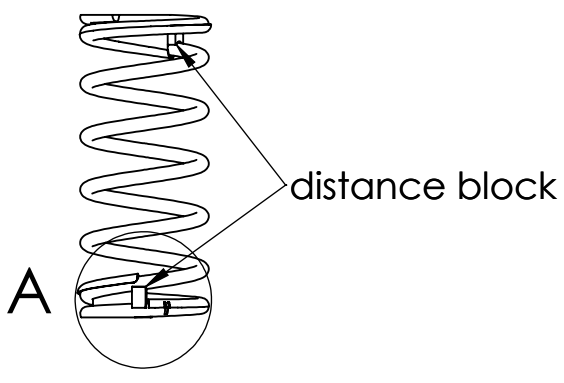

view 1

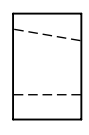
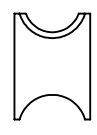
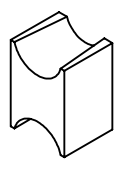

view 2

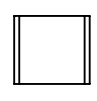

B

View A

C

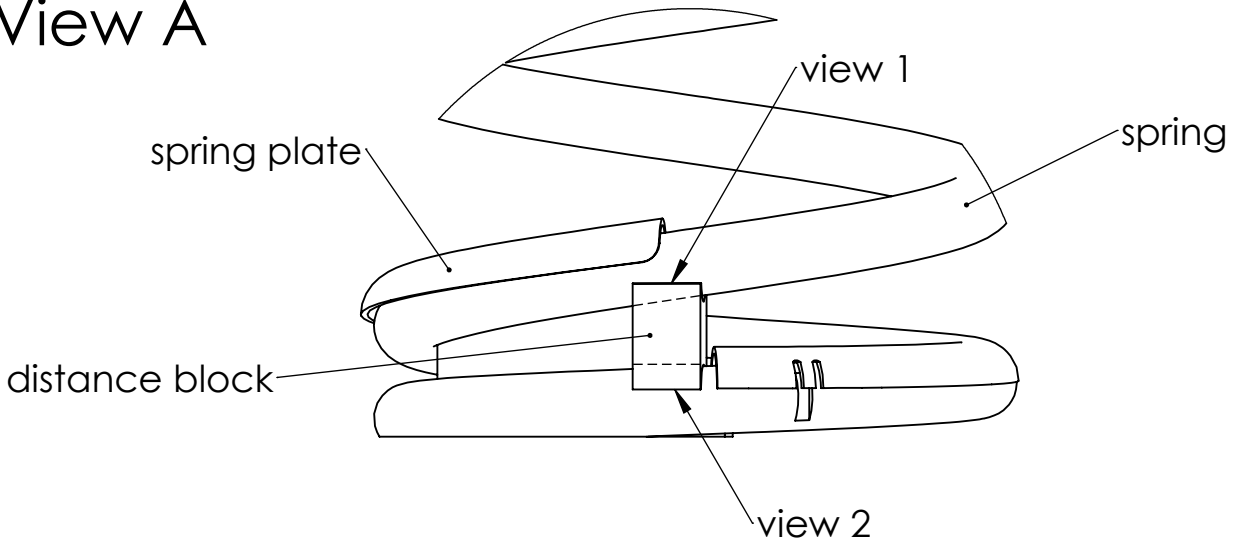

D

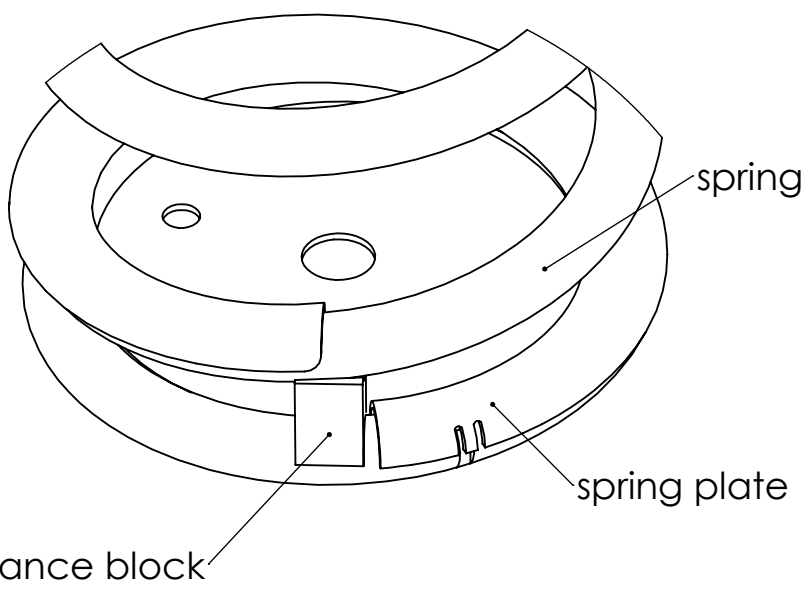

E

UNLESS OTHERWISE SPECIFIED:
DIMENSIONS ARE IN MILLIMETERS
WEIGHT ARE IN KILOGRAMM

	NAME	SIGNATURE	DATE	REVISION
DRAWN	E.Reispere		30.01.2025	
APPV'D				

PART NUMBER / DWG NO.: VL55

DESCRIPTION: Spring swing RACOON

F



Tiptiptap OÜ

MATERIAL: metal, plastic A4

WEIGHT: SCALE: 1:4 SHEET 7 OF 10

A

B

C

D

E

F

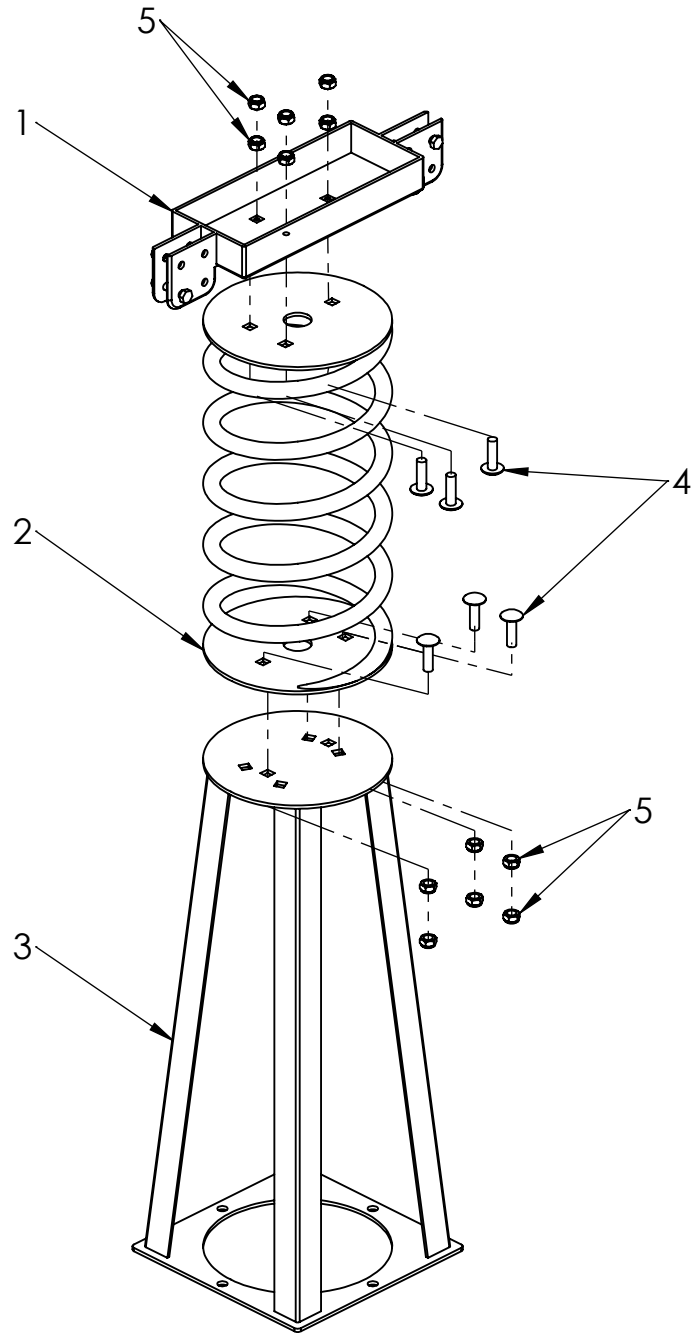

ITEM NO.	PART NUMBER
1	central console
2	spring with spring disk
3	ground fixing
4	bolt M10x35 DIN603
5	nut DIN985 M10

UNLESS OTHERWISE SPECIFIED:
 DIMENSIONS ARE IN MILLIMETERS
 WEIGHT ARE IN KILOGRAMM

PART NUMBER / DWG NO.:
VL55

	NAME	SIGNATURE	DATE	REVISION
DRAWN	E.Reispere		30.01.2025	
APPV'D				

DESCRIPTION:
Spring swing RACOON



MATERIAL:	metal, plastic	A4
WEIGHT:	SCALE: 1:10	SHEET 8 OF 10

A

B

C

D

E

F

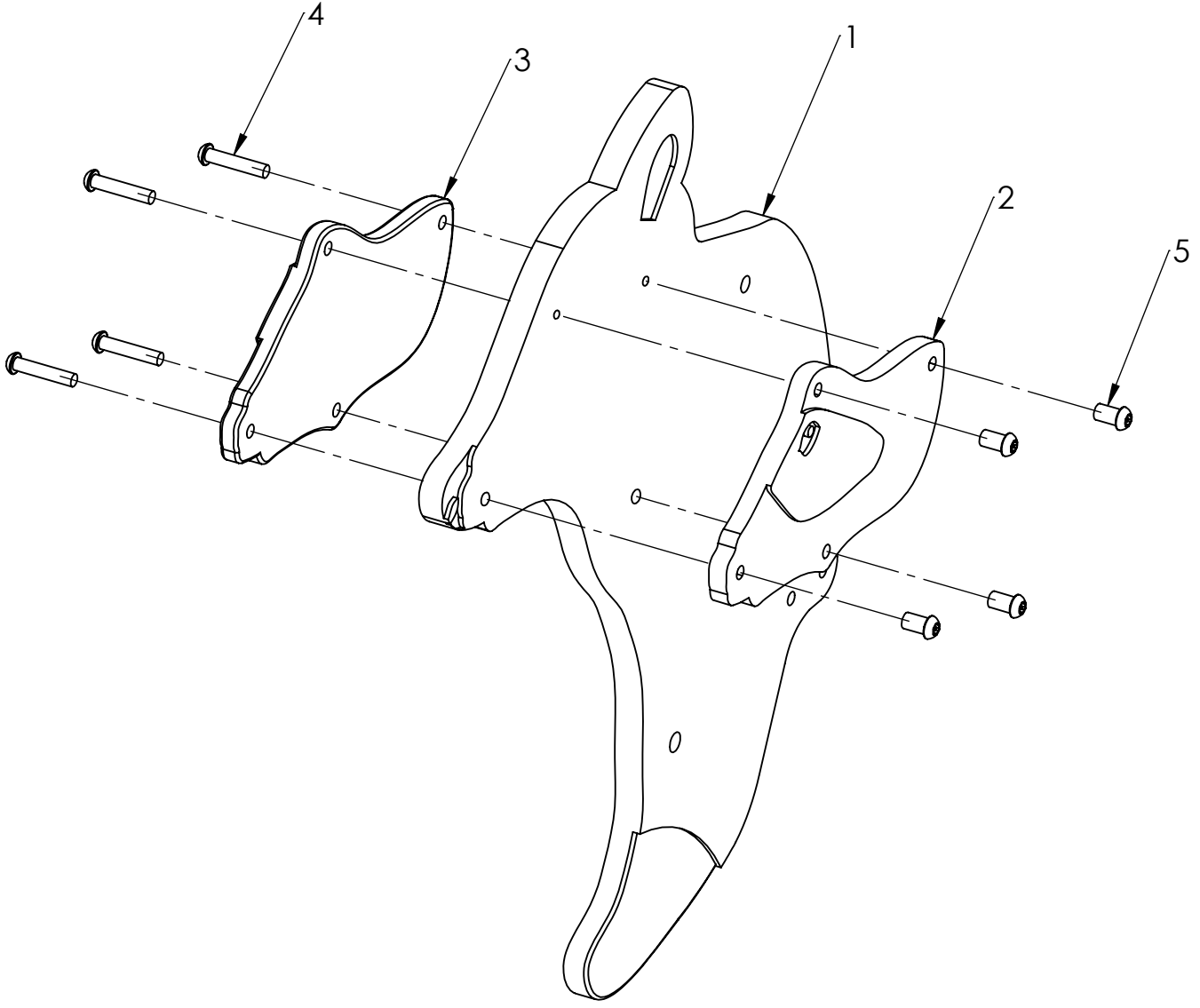

ITEM NO.	PART NUMBER
1	VL55 body panel
2	VL55 face panel 2
3	VL55 face panel 1
4	bolt M8x40 Art. 9121
5	barrel nut M18x16 Art.9121

UNLESS OTHERWISE SPECIFIED: DIMENSIONS ARE IN MILLIMETERS WEIGHT ARE IN KILOGRAMM				
	NAME	SIGNATURE	DATE	REVISION
DRAWN	E.Reispere		30.01.2025	
APPV'D				

PART NUMBER / DWG NO.:
VL55

DESCRIPTION:
**Spring swing RACOON
connecting face and body panels**



MATERIAL:	metal, plastic	A4
WEIGHT:		SCALE: 1:10
		SHEET 9 OF 10

A

B

C

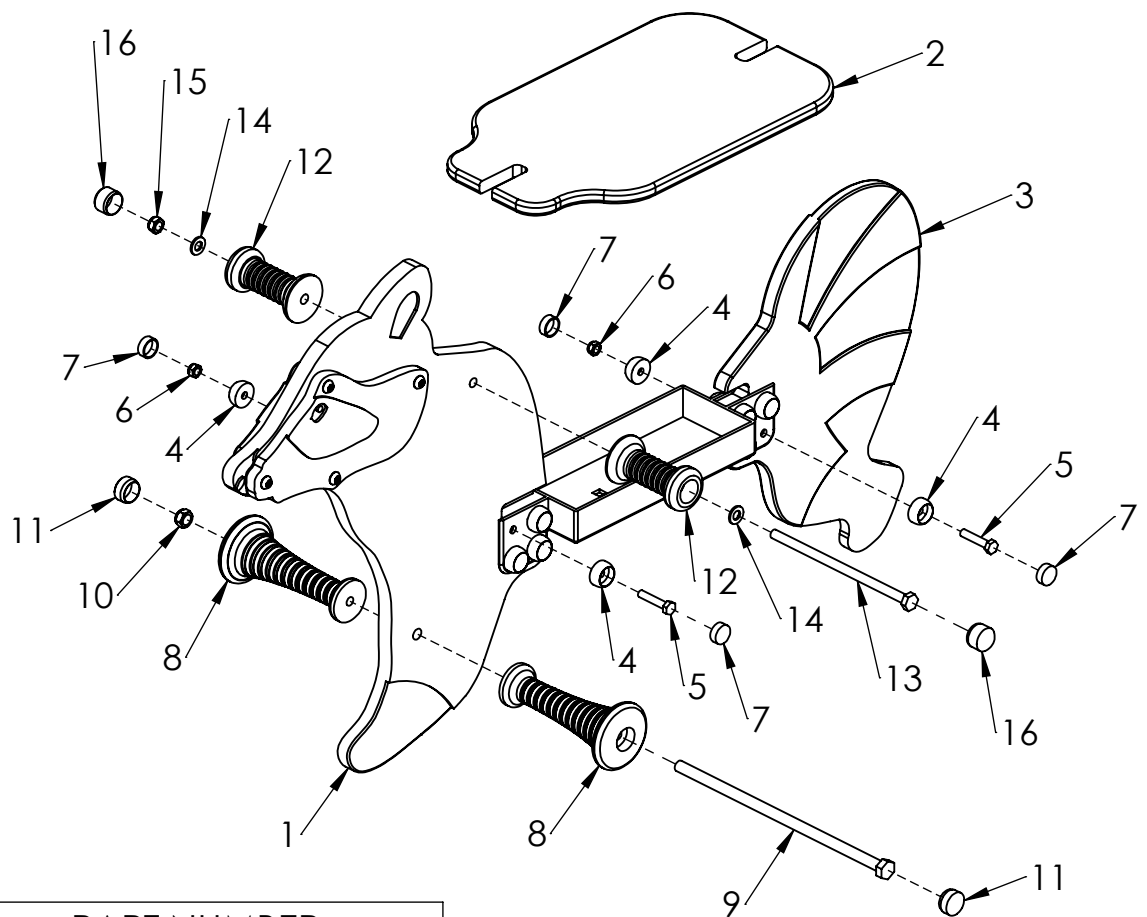

ITEM NO.	PART NUMBER
1	VL55 body panel
2	seat for spring swing
3	VL55 tail
4	nut cover M8
5	bolt DIN933 M8x40
6	nut DIN985 M8
7	nut cover cap M8
8	leg support n
9	bolt M12x305 DIN931
10	nut DIN985 M12
11	leg support n cover cup
12	handle new
13	bolt M10x200 DIN931
14	washer M10 DIN125
15	nut DIN985 M10
16	handle new cup

D

E

F

UNLESS OTHERWISE SPECIFIED:
DIMENSIONS ARE IN MILLIMETERS
WEIGHT ARE IN KILOGRAMM

	NAME	SIGNATURE	DATE	REVISION
DRAWN	E.Reispere		30.01.2025	
APPV'D				

PART NUMBER / DWG NO.:

VL55

DESCRIPTION:

Spring swing RACOON

MATERIAL:

metal, plastic

A4

WEIGHT:

SCALE: 1:10

SHEET 10 OF 10



Tiptiptap OÜ