

A

B

C

D

E

F

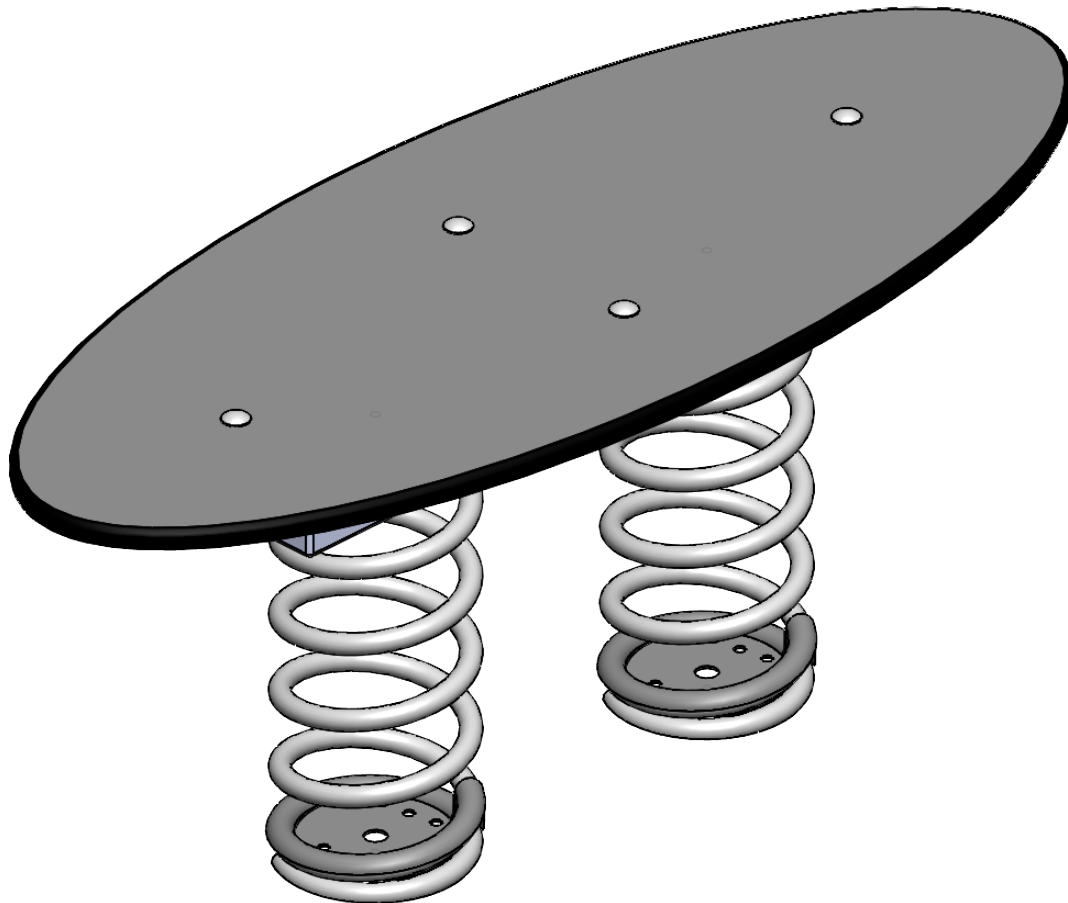

UNLESS OTHERWISE SPECIFIED:
 DIMENSIONS ARE IN MILLIMETERS
 WEIGHT ARE IN KILOGRAMM

PART NUMBER / DWG NO.:

PV016 MF

| | NAME | SIGNATURE | DATE | REVISION |
|--------|------------|-----------|------------|----------|
| DRAWN | E.Reispere | | 28.06.2022 | |
| APPV'D | | | | |

DESCRIPTION:

Balance stand on springs SURFY



Tiptiptap⁰⁰

MATERIAL:

metal, plastic

A4

WEIGHT:

SCALE: 1:20

SHEET 1 OF 9

safety area

A

B

C

D

E

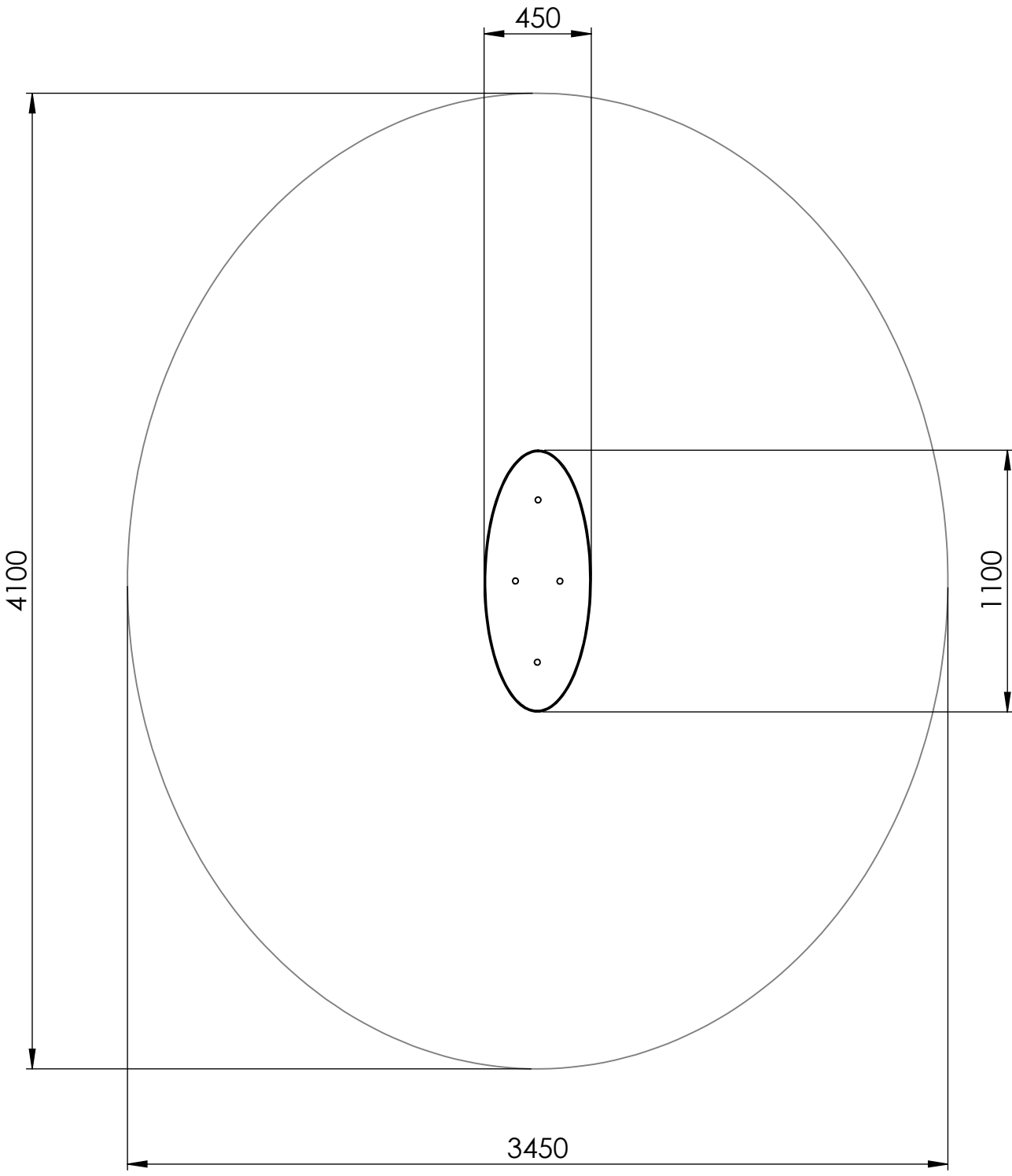

UNLESS OTHERWISE SPECIFIED:
 DIMENSIONS ARE IN MILLIMETERS
 WEIGHT ARE IN KILOGRAMM

PART NUMBER / DWG NO.:
PV016 MF

| | NAME | SIGNATURE | DATE | REVISION |
|--------|------------|-----------|------------|----------|
| DRAWN | E.Reispere | | 28.06.2022 | |
| APPV'D | | | | |

DESCRIPTION:
Balance stand on springs SURFY



| | | |
|-----------|----------------|--------------|
| MATERIAL: | metal, plastic | A4 |
| WEIGHT: | | SCALE: 1:20 |
| | | SHEET 2 OF 9 |

foundation

A

B

C

D

E

F

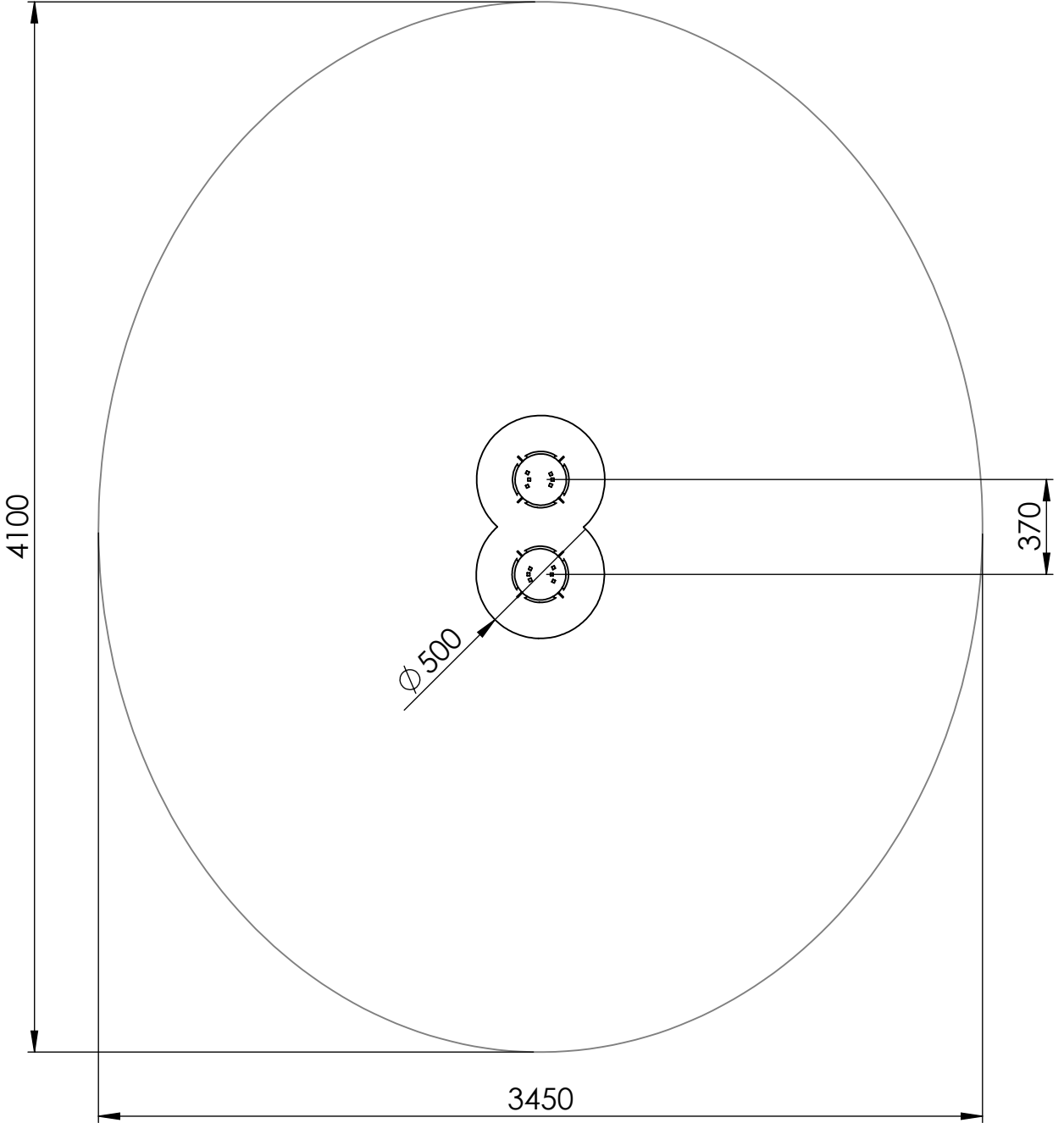

| | | | | |
|---|------------|-----------|------------|----------|
| UNLESS OTHERWISE SPECIFIED: DIMENSIONS ARE IN MILLIMETERS WEIGHT ARE IN KILOGRAMM | | | | |
| | NAME | SIGNATURE | DATE | REVISION |
| DRAWN | E.Reispere | | 28.06.2022 | |
| APPV'D | | | | |

PART NUMBER / DWG NO.:
PV016 MF

DESCRIPTION:
Balance stand on springs SURFY



| | | |
|-----------|----------------|--------------|
| MATERIAL: | metal, plastic | A4 |
| WEIGHT: | SCALE: 1:20 | SHEET 3 OF 9 |

A

B

C

D

E

F

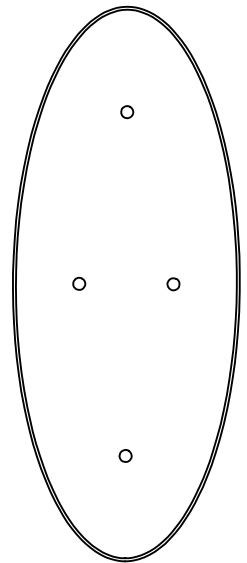
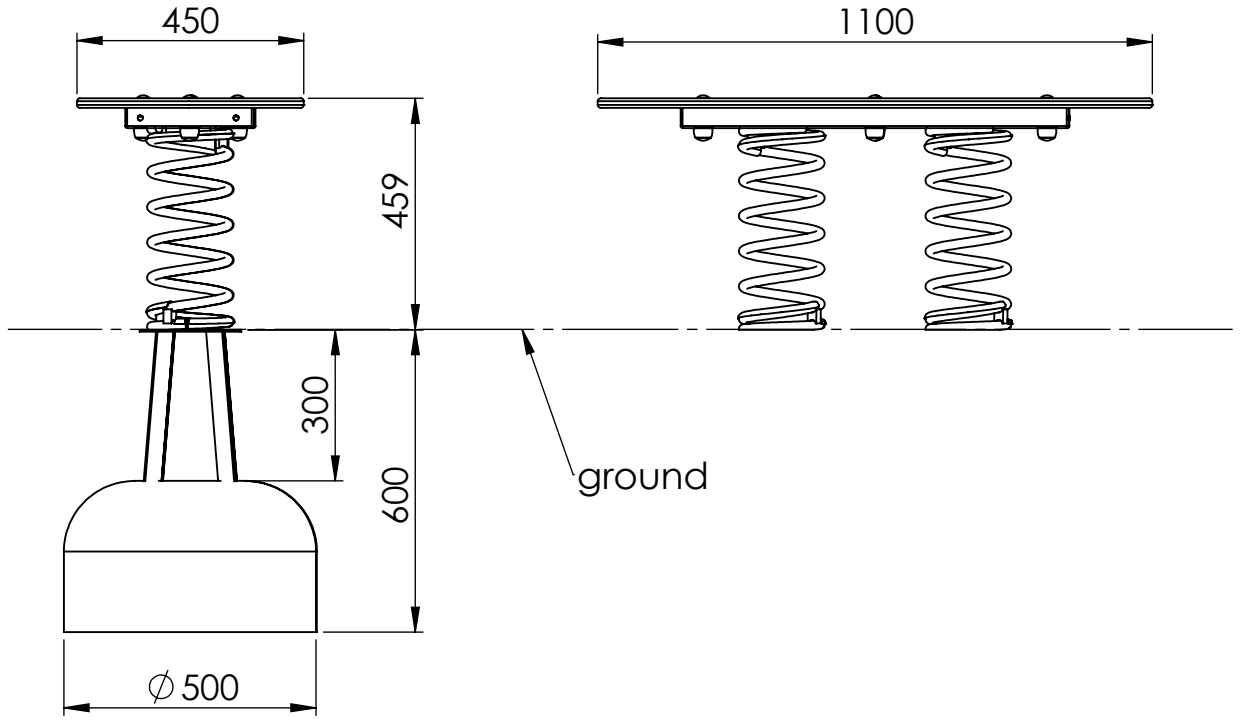

UNLESS OTHERWISE SPECIFIED:
 DIMENSIONS ARE IN MILLIMETERS
 WEIGHT ARE IN KILOGRAMM

PART NUMBER / DWG NO.:
PV016 MF

| | NAME | SIGNATURE | DATE | REVISION |
|--------|------------|-----------|------------|----------|
| DRAWN | E.Reispere | | 28.06.2022 | |
| APPV'D | | | | |

DESCRIPTION:
Balance stand on springs SURFY



| | | |
|-----------|----------------|--------------|
| MATERIAL: | metal, plastic | A4 |
| WEIGHT: | | SCALE: 1:15 |
| | | SHEET 4 OF 9 |

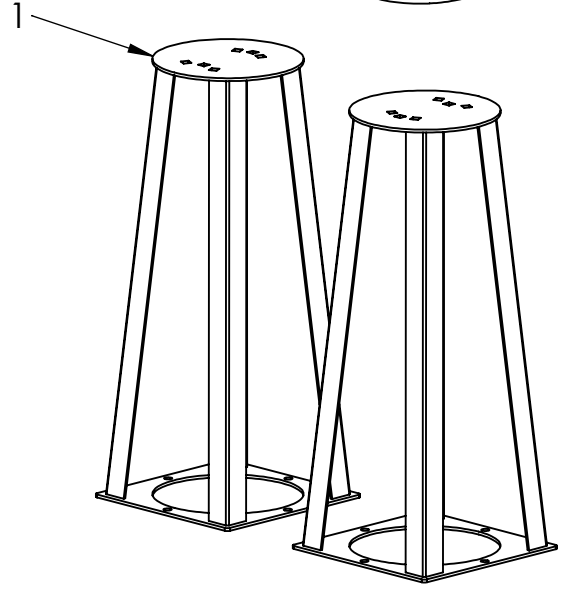
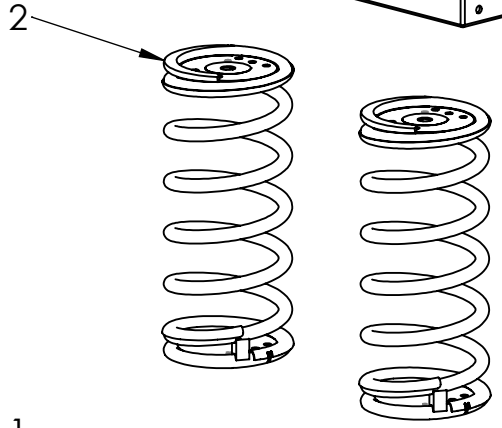
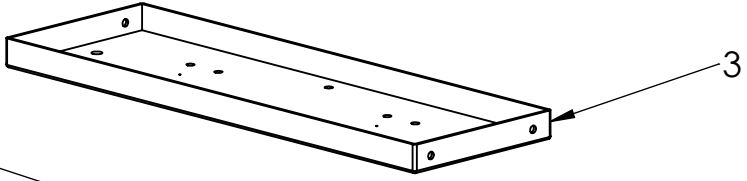
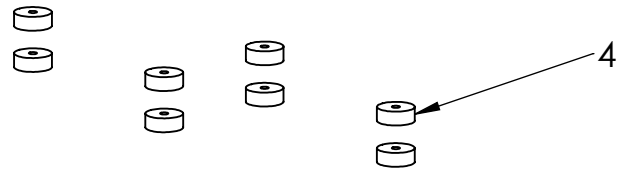
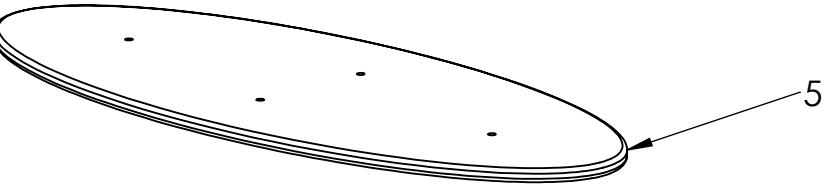

| ITEM NO. | PART NUMBER |
|----------|-----------------------|
| 1 | ground fixing |
| 2 | spring |
| 3 | central console |
| 4 | distance bushing 19mm |
| 5 | PV016 panel |
| 6 | distance block |

UNLESS OTHERWISE SPECIFIED:
DIMENSIONS ARE IN MILLIMETERS
WEIGHT ARE IN KILOGRAMM

PART NUMBER / DWG NO.:
PV016 MF

| | NAME | SIGNATURE | DATE | REVISION |
|--------|------------|-----------|------------|----------|
| DRAWN | E.Reispere | | 28.06.2022 | |
| APPV'D | | | | |

DESCRIPTION:
Balance stand on springs SURFY



| | | |
|-----------|----------------|--------------|
| MATERIAL: | metal, plastic | A4 |
| WEIGHT: | | SCALE: 1:15 |
| | | SHEET 5 OF 9 |

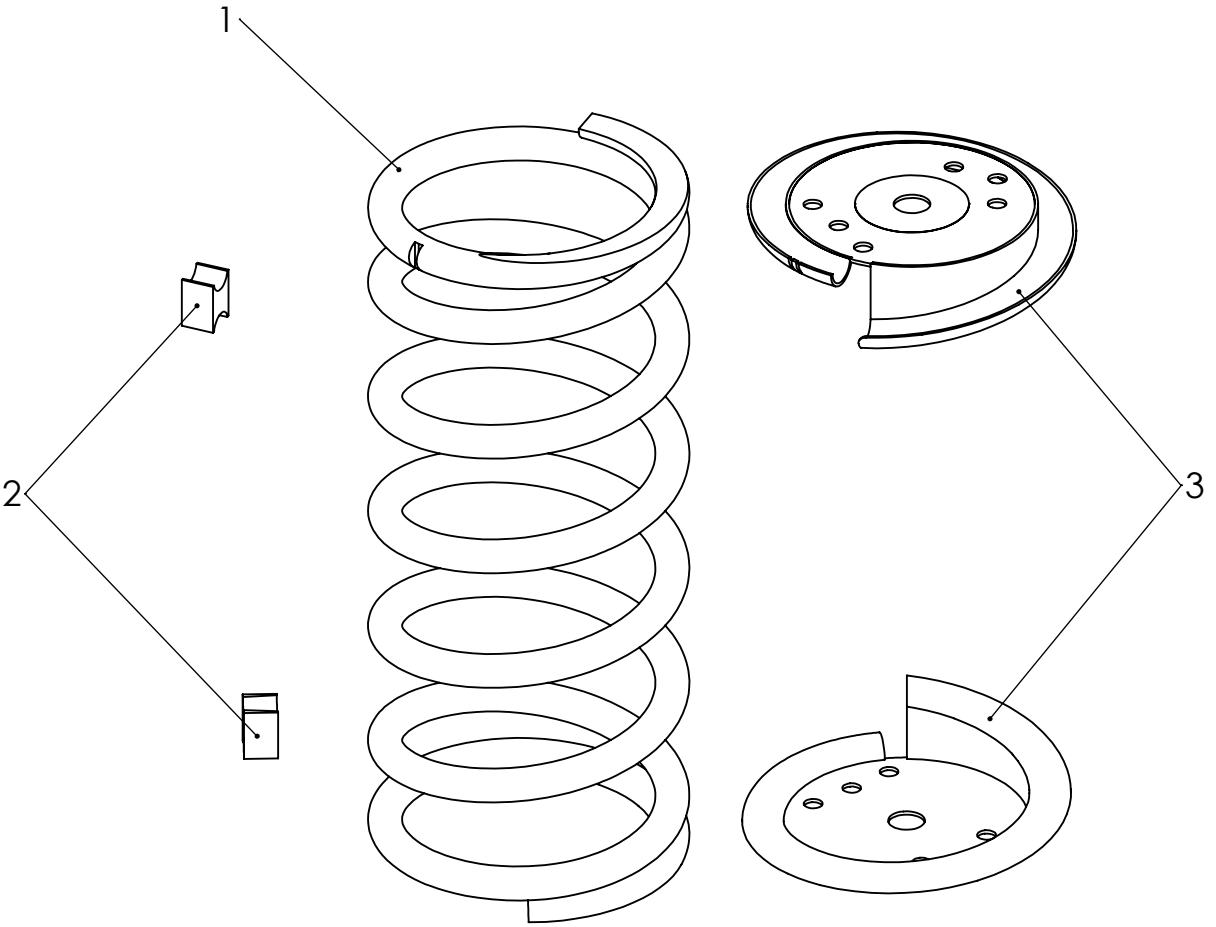

| ITEM NO. | PART NUMBER | DESCRIPTION | QTY. |
|----------|----------------|---------------|------|
| 1 | spring | painted steel | 1 |
| 2 | distance block | HP plastic | 2 |
| 3 | spring plate | painted steel | 2 |

UNLESS OTHERWISE SPECIFIED:
DIMENSIONS ARE IN MILLIMETERS
WEIGHT ARE IN KILOGRAMM

PART NUMBER / DWG NO.:

PV016 MF

| | NAME | SIGNATURE | DATE | REVISION |
|--------|------------|-----------|------------|----------|
| DRAWN | E.Reispere | | 28.06.2022 | |
| APPV'D | | | | |

DESCRIPTION:

Balance stand on springs SURFY

MATERIAL:

metal, plastic

A4

WEIGHT:

SCALE: 1:4

SHEET 6 OF 9



Tiptiptap OÜ

A

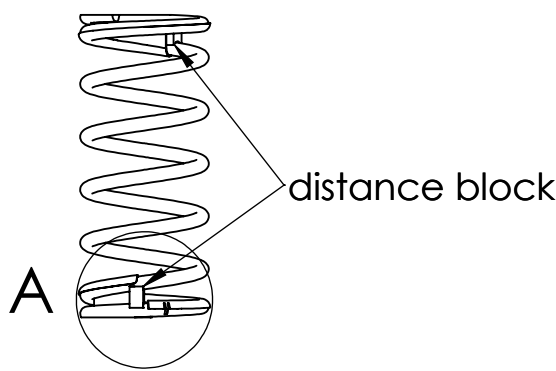

view 1

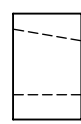
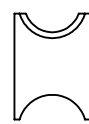
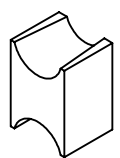

view 2

B

View A

C

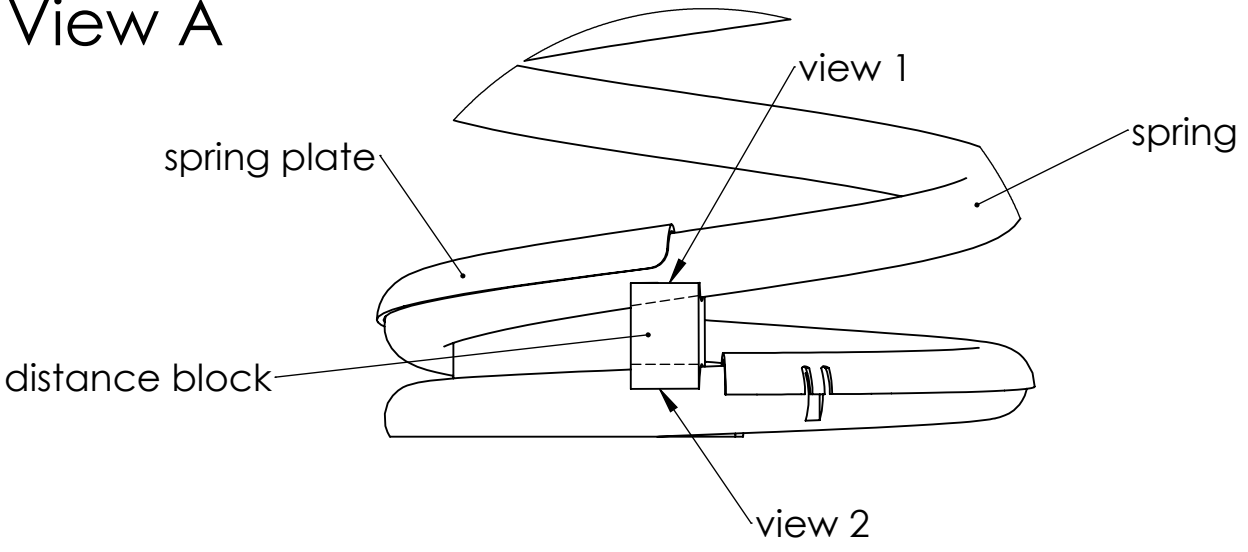

D

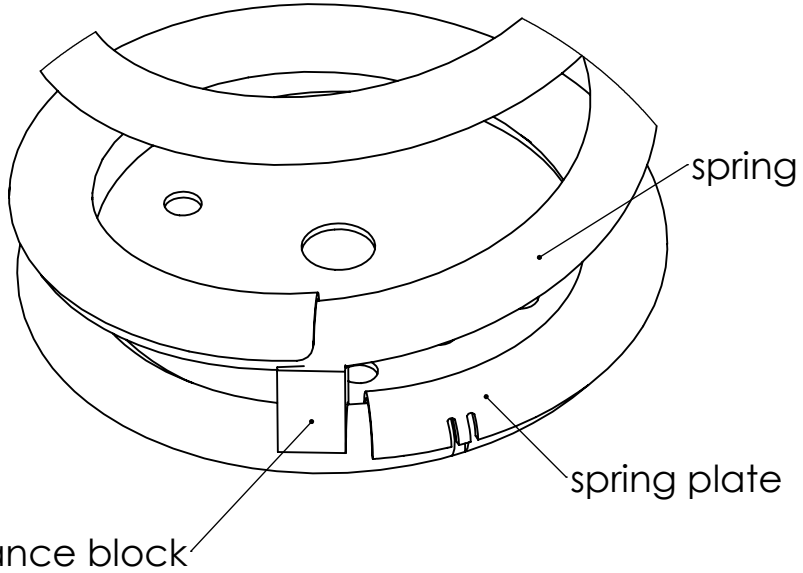

E

UNLESS OTHERWISE SPECIFIED:
DIMENSIONS ARE IN MILLIMETERS
WEIGHT ARE IN KILOGRAMM

| | NAME | SIGNATURE | DATE | REVISION |
|--------|------------|-----------|------------|----------|
| DRAWN | E.Reispere | | 28.06.2022 | |
| APPV'D | | | | |

PART NUMBER / DWG NO.:
PV016 MF

DESCRIPTION:
Balance stand on springs SURFY

F



Tiptiptap ^{OO}

| | | |
|-----------|----------------|--------------|
| MATERIAL: | metal, plastic | A4 |
| WEIGHT: | SCALE: 1:4 | SHEET 7 OF 9 |

A

B

C

D

E

F

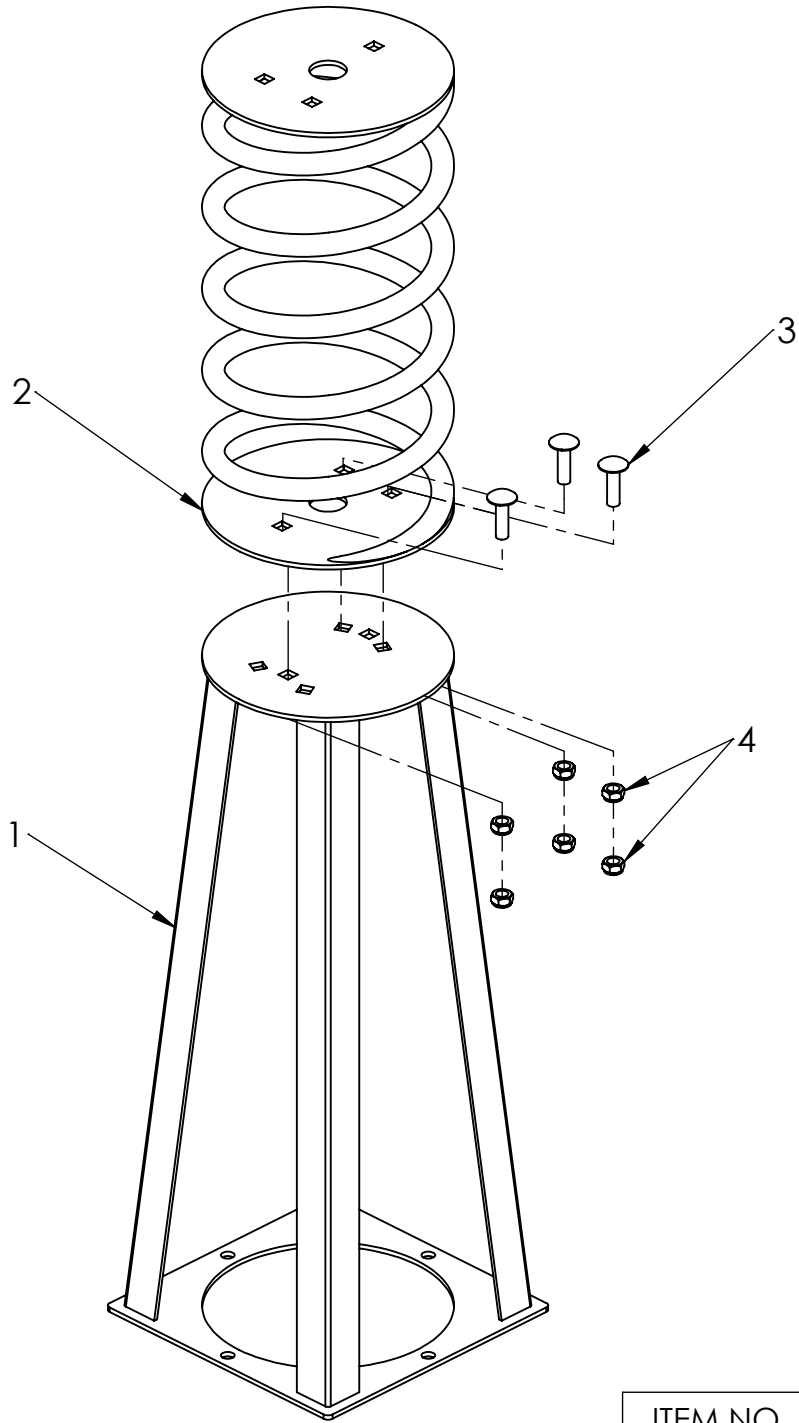

| ITEM NO. | PART NUMBER |
|----------|-------------------------|
| 1 | ground fixing |
| 2 | spring with spring disk |
| 3 | bolt DIN603 M10x35 |
| 4 | nut DIN985 M10 |

UNLESS OTHERWISE SPECIFIED:
 DIMENSIONS ARE IN MILLIMETERS
 WEIGHT ARE IN KILOGRAMM

PART NUMBER / DWG NO.:

PV016 MF

| | NAME | SIGNATURE | DATE | REVISION |
|--------|------------|-----------|------------|----------|
| DRAWN | E.Reispere | | 28.06.2022 | |
| APPV'D | | | | |

DESCRIPTION:

Balance stand on springs SURFY

MATERIAL:

metal, plastic

A4

WEIGHT:

SCALE: 1:10

SHEET 8 OF 9



Tiptiptap ^{OO}

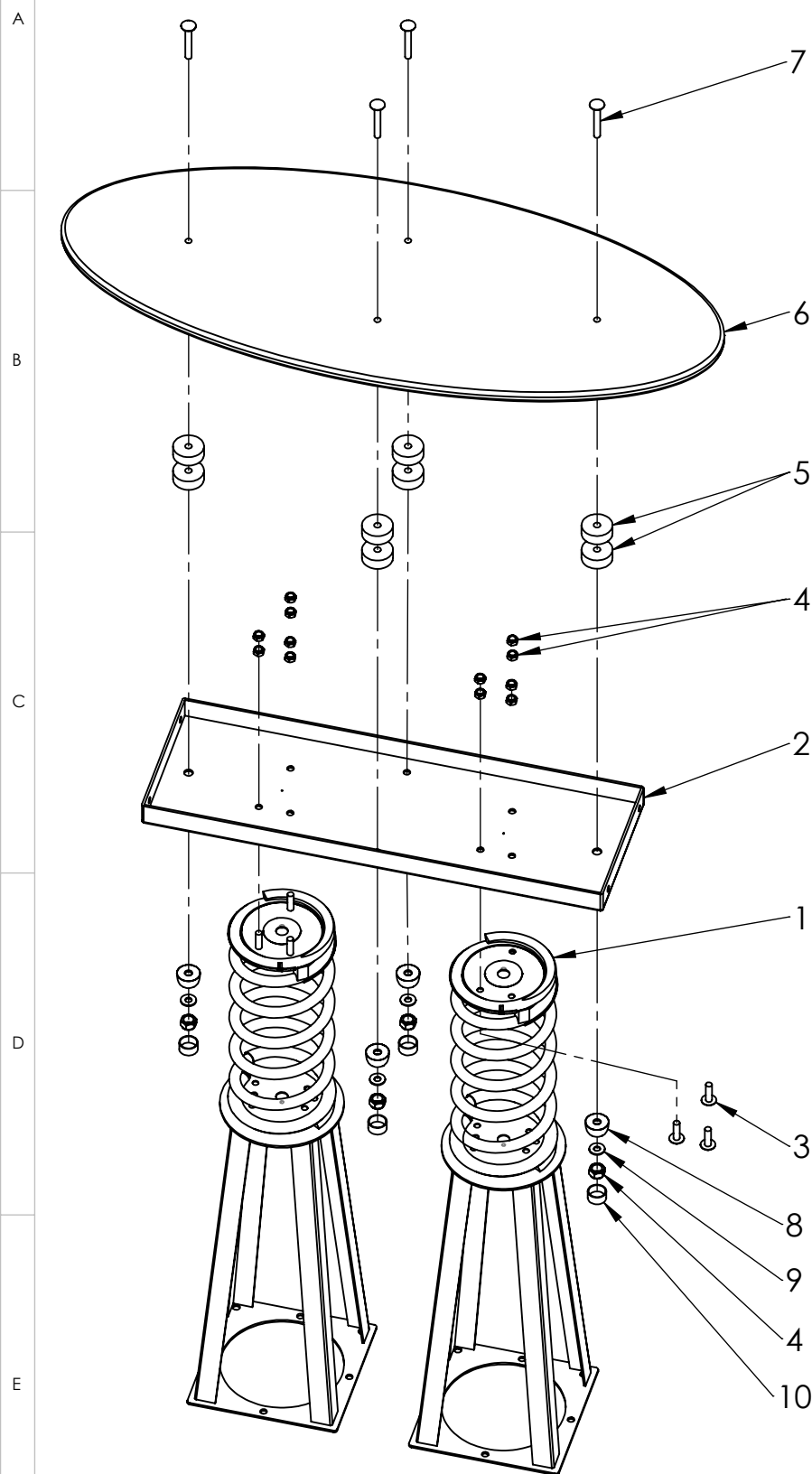

| ITEM NO. | PART NUMBER |
|----------|-----------------------|
| 1 | spring |
| 2 | central console |
| 3 | bolt DIN603 M10x35 |
| 4 | nut DIN985 M10 |
| 5 | distance bushing 19mm |
| 6 | PV016 panel |
| 7 | bolt DIN603 M10x70 |
| 8 | nut cover M12 |
| 9 | washer M10 DIN9054 |
| 10 | nut cover cap M12 |

UNLESS OTHERWISE SPECIFIED:
DIMENSIONS ARE IN MILLIMETERS
WEIGHT ARE IN KILOGRAMM

PART NUMBER / DWG NO.:

PV016 MF

| | NAME | SIGNATURE | DATE | REVISION |
|--------|------------|-----------|------------|----------|
| DRAWN | E.Reispere | | 28.06.2022 | |
| APPV'D | | | | |

DESCRIPTION:

Balance stand on springs SURFY

F



Tiptiptap OÜ

MATERIAL:

metal, plastic

A4

WEIGHT:

SCALE: 1:10

SHEET 9 OF 9