

A

B

C

D

E

F

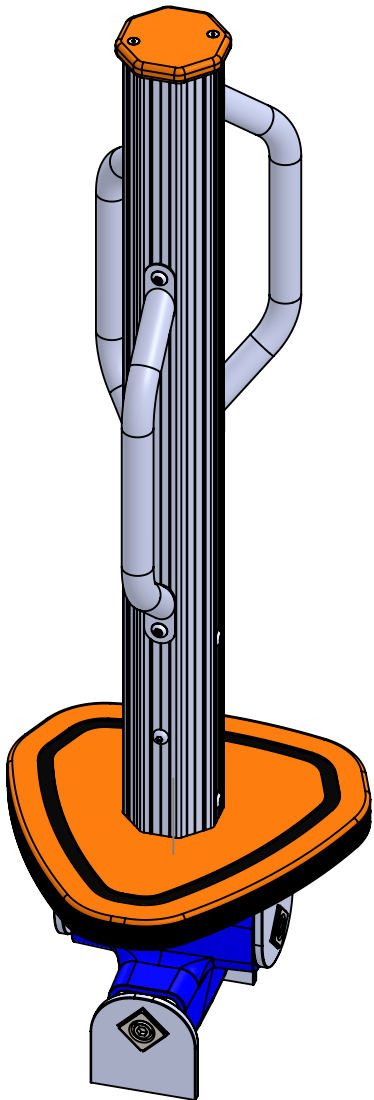

UNLESS OTHERWISE SPECIFIED:
 DIMENSIONS ARE IN MILLIMETERS
 WEIGHT ARE IN KILOGRAMM

PART NUMBER / DWG NO.: **OCT003**

	NAME	SIGNATURE	DATE	REVISION
DRAWN	M.Kalamees		08/04/2024	
APPV'D				

DESCRIPTION:
Shaker



MATERIAL:		A4
WEIGHT:	SCALE: 1:8	SHEET 1 OF 6

safety area

A

B

C

D

E

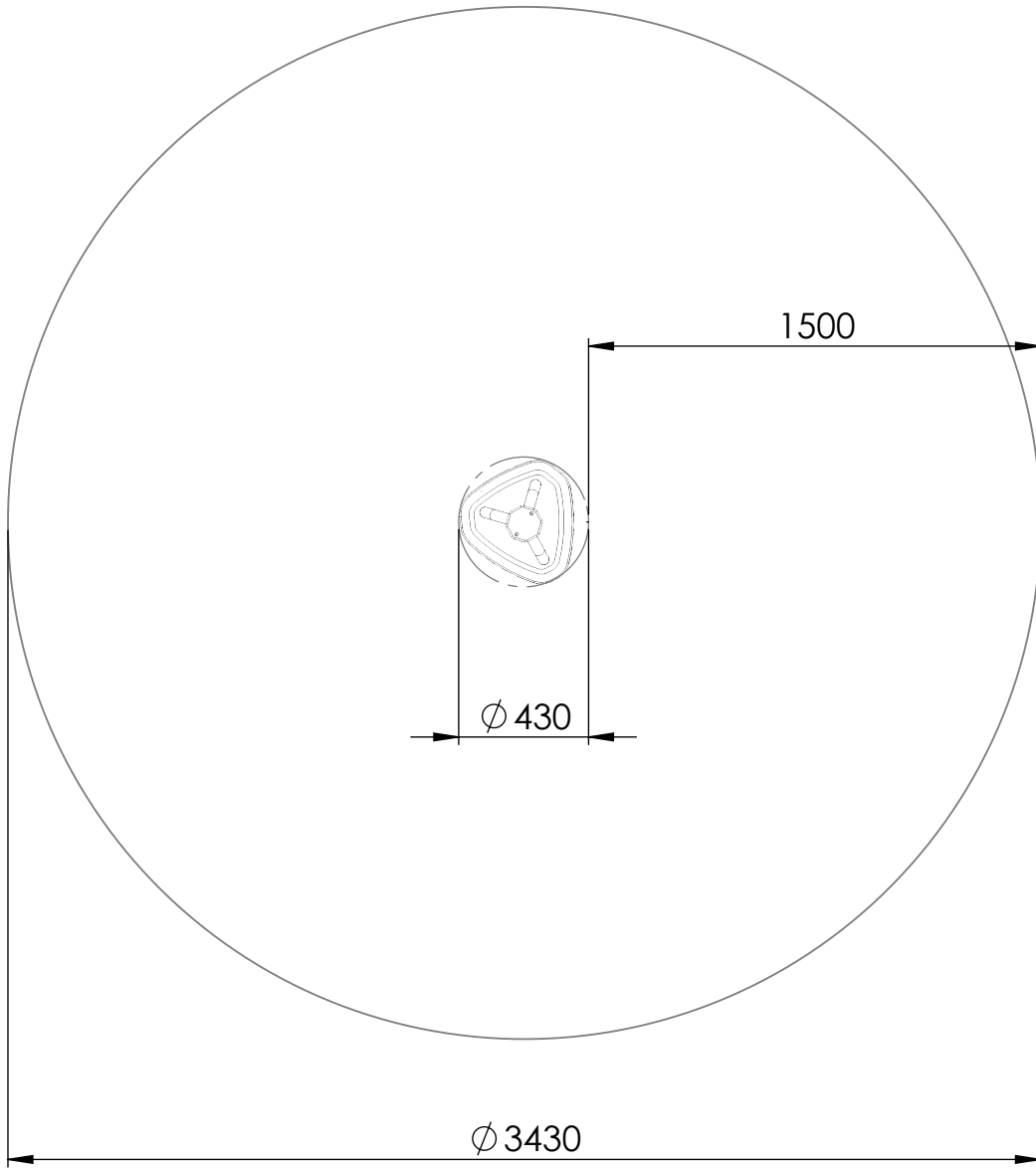

F

UNLESS OTHERWISE SPECIFIED: DIMENSIONS ARE IN MILLIMETERS WEIGHT ARE IN KILOGRAMM				Product code: OCT003	
	NAME	SIGNATURE	DATE	DESCRIPTION: Shaker	
DRAWN	M.Kalamees		08/04/2024		
 Tiptiptap ^{ÖÜ}					
				WEIGHT:	SCALE: 1:8

foundation

A

B

C

D

E

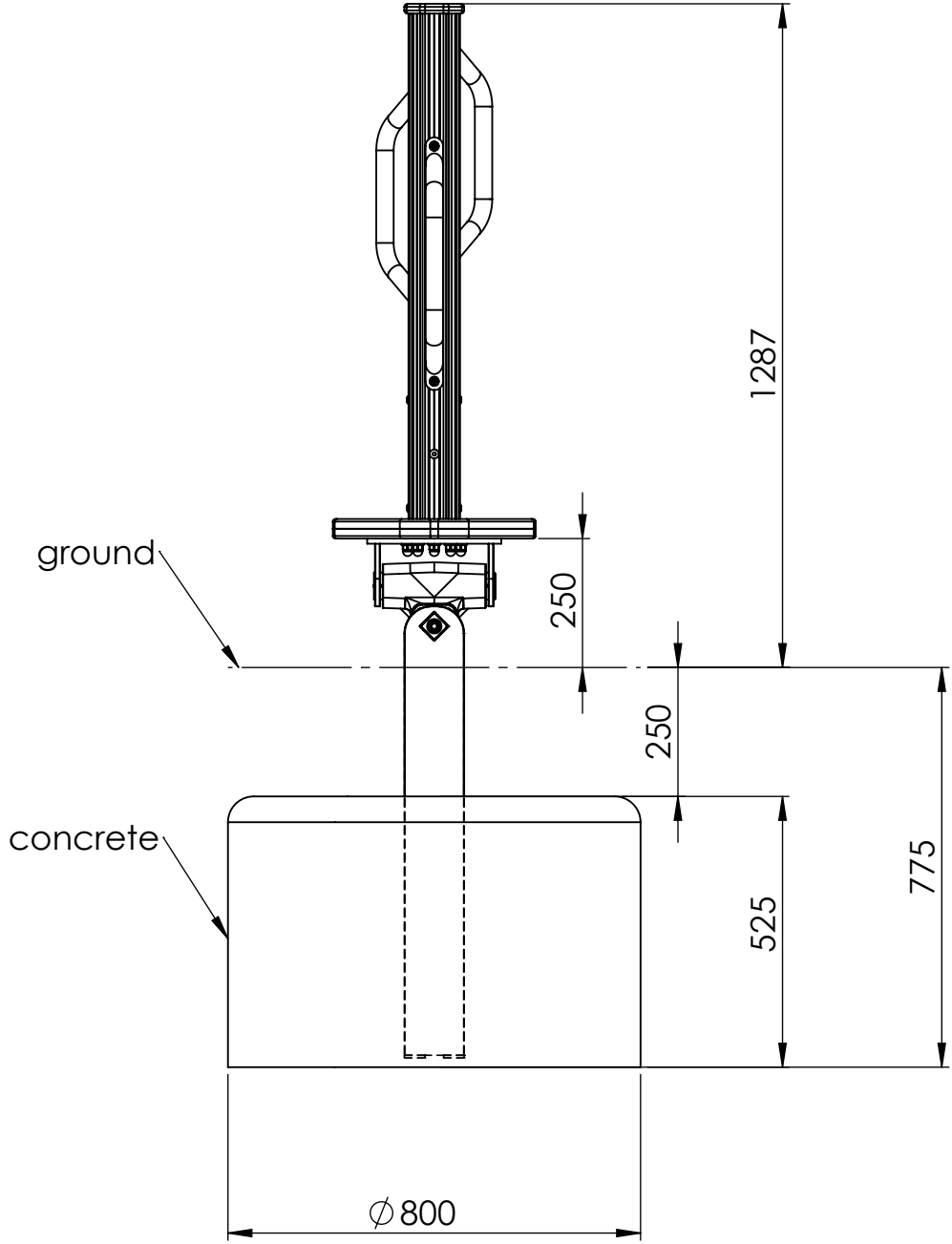

UNLESS OTHERWISE SPECIFIED:
 DIMENSIONS ARE IN MILLIMETERS
 WEIGHT ARE IN KILOGRAMM

Product code: **OCT003**

	NAME	SIGNATURE	DATE
DRAWN	M.Kalamees		08/04/2024

DESCRIPTION: **Shaker**



WEIGHT:	SCALE: 1:8	A4
		SHEET 3 OF 6

F

A

B

C

D

E

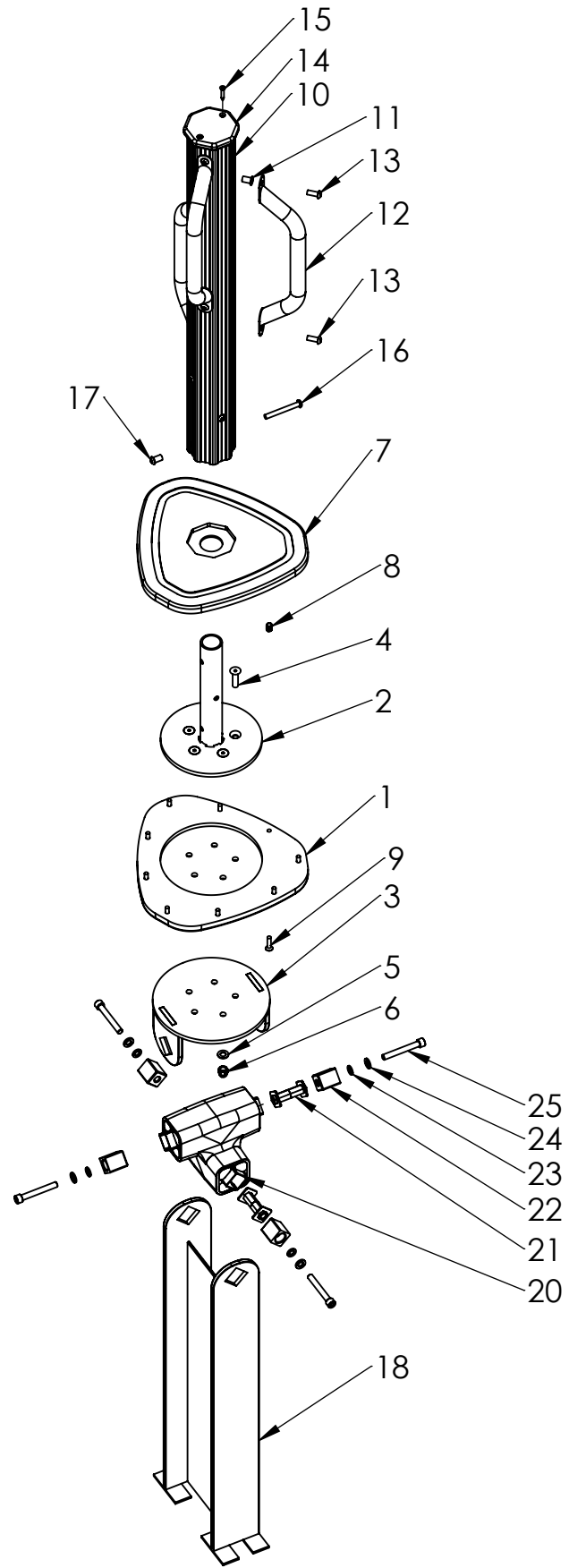

UNLESS OTHERWISE SPECIFIED:
 DIMENSIONS ARE IN MILLIMETERS
 WEIGHT ARE IN KILOGRAMM

	NAME	SIGNATURE	DATE	REVISION
DRAWN	M.Kalamees		08/04/2024	
APPV'D				

PART NUMBER / DWG NO.: **OCT003**

DESCRIPTION:
Shaker



MATERIAL:		A4
WEIGHT:	SCALE: 1:14	SHEET 4 OF 6

	ITEM NO.	PART NUMBER	QTY.
A	1	spinning base, plate 1	1
	2	spinner fixing plate	1
	3	fastening plate	1
	4	bolt M12x40 DIN 7991	5
	5	washer M12	5
	6	domed cap nut M12 DIN1587	5
B	7	spinning base, plate 2	1
	8	furniture nut M8	9
	9	bolt M8x30 DIN7991	9
	10	post L1000	1
	11	rivet nut M10	6
	12	OCT handle	3
	13	bolt M10x25 ISO7380	6
	14	upper plastic cap	1
C	15	wood screw 6x40	2
	16	bolt M10x85 ISO7380	3
	17	pin torx nut M10x20	3
	18	ground fixing	1
	19	torsion spring AK50	1
	20	Square pipe 40x40x2	2
	21	Inner nut M12	2
	22	Square cone	4
	23	washer M12 DIN127	4
	24	washer M12 DIN126	4
D	25	bolt M12x90 DIN 912	4

E				

F	UNLESS OTHERWISE SPECIFIED: DIMENSIONS ARE IN MILLIMETERS WEIGHT ARE IN KILOGRAMM				PART NUMBER / DWG NO.:		OCT003	
		NAME	SIGNATURE	DATE	REVISION	DESCRIPTION: Shaker		
	DRAWN	M.Kalamees		08/04/2024				
	APPV'D							
	 Tiptiptap OÜ					MATERIAL:		A4
					WEIGHT:		SCALE: 1:14	SHEET 5 OF 6

ITEM NO.	PART NUMBER	QTY.	REMARK
1	Torsion spring AK50	1	
2	Inner nut M12	2	stainless steel, (AISI304)
3	Spring attachment	2	fastening plate/ground fixing
4	Square cone	4	stainless steel, (AISI304)
5	Square pipe 40x40x2	2	stainless steel, (AISI304)
6	Bolt M12x90 DIN912	4	stainless steel, (AISI304)
7	Washer M12 DIN127	4	
8	Washer M12 DIN126	4	

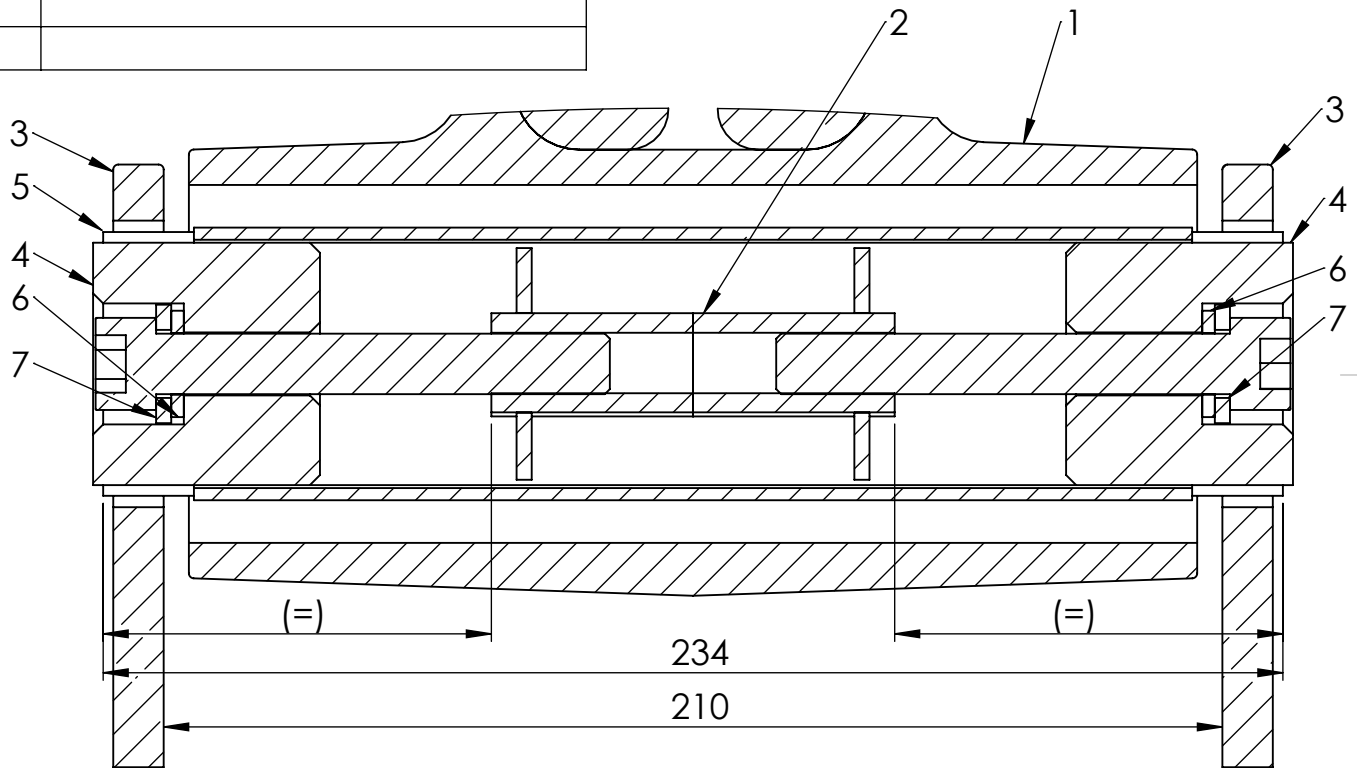

NB! When installing a spring with cones (4), the bolts (6) must be fastened equally so that the inner nut (2) remains in the center of the pipe (5).

UNLESS OTHERWISE SPECIFIED: DIMENSIONS ARE IN MILLIMETERS WEIGHT ARE IN KILOGRAMM				Product code: OCT003	
	NAME	SIGNATURE	DATE	DESCRIPTION: Attaching the spring	
DRAWN	M.Kalamees		08/04/2024		A4
 Tiptap OÜ				WEIGHT:	SCALE: 1:20
				SHEET 6 OF 6	