

A

B

C

D

E

F

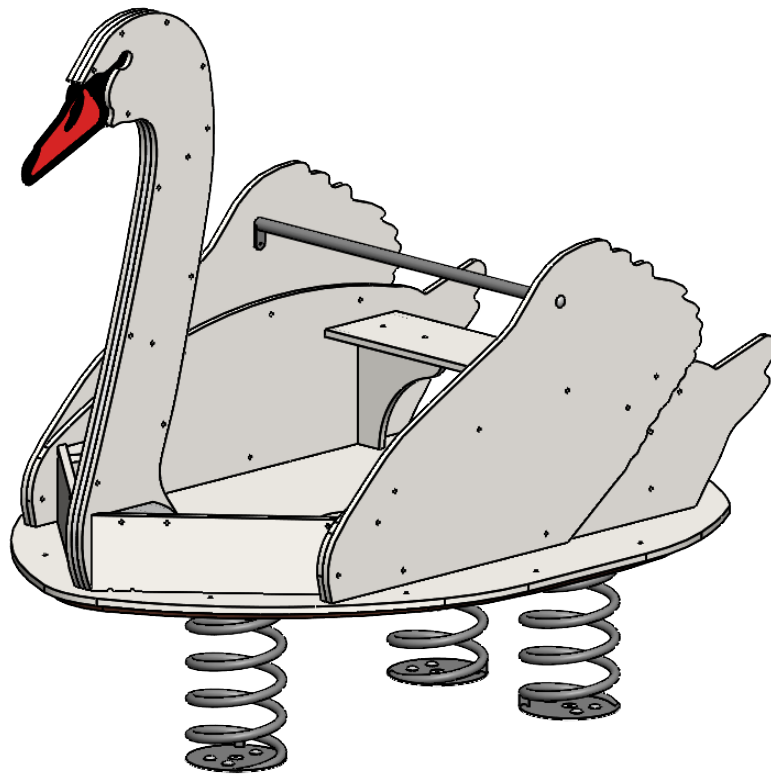

UNLESS OTHERWISE SPECIFIED:
 DIMENSIONS ARE IN MILLIMETERS
 WEIGHT ARE IN KILOGRAMM

PART NUMBER / DWG NO.:
VL53

	NAME	SIGNATURE	DATE	REVISION
DRAWN	E.Reispere		01.08.2024	
APPV'D				

DESCRIPTION:
Spring swing SWAN



MATERIAL:	wood, metal, plastic	A4
WEIGHT:		SCALE: 1:50
		SHEET 1 OF 18

safety area

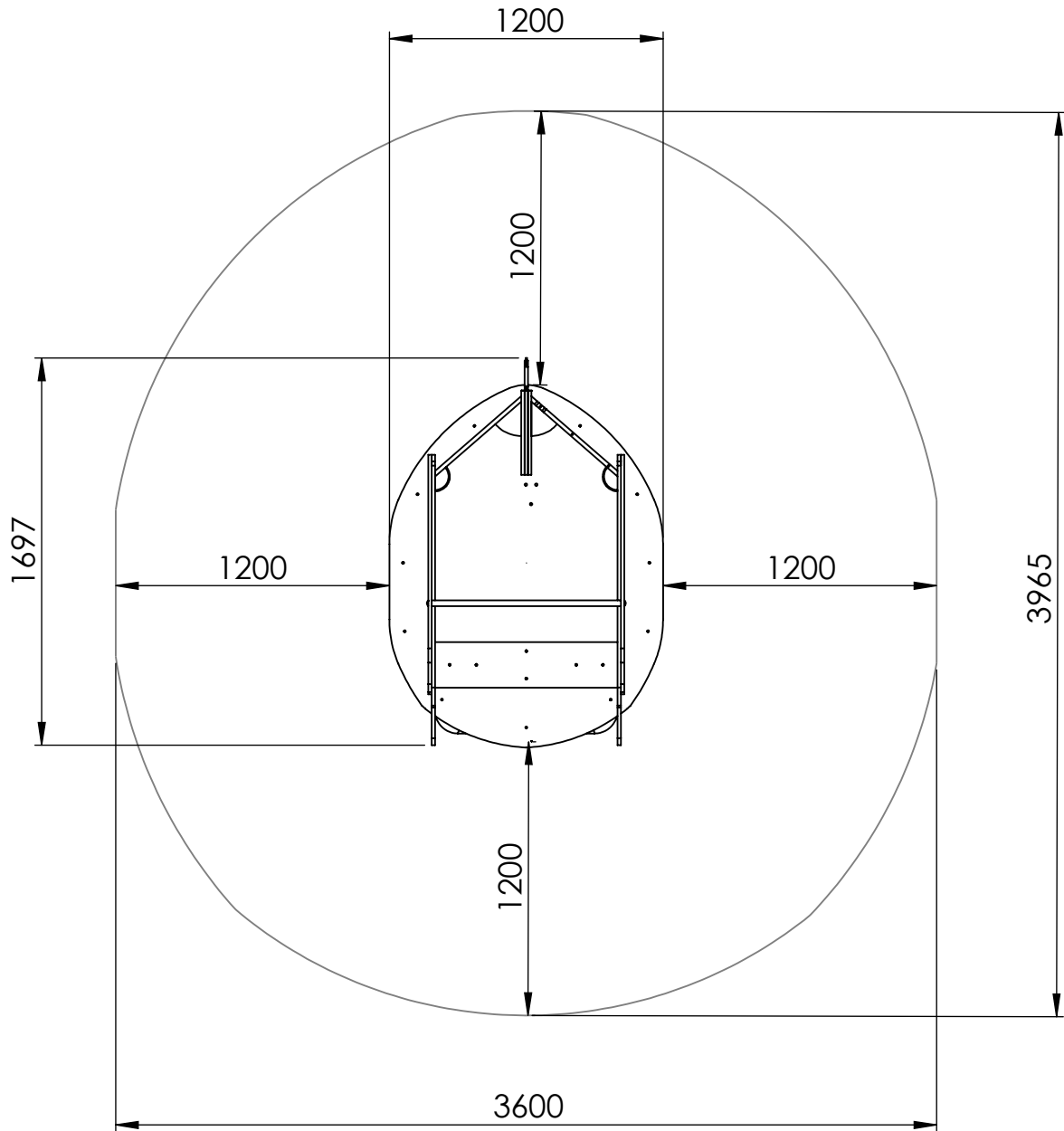

UNLESS OTHERWISE SPECIFIED:
DIMENSIONS ARE IN MILLIMETERS
WEIGHT ARE IN KILOGRAMM

PART NUMBER / DWG NO.:

VL53

	NAME	SIGNATURE	DATE	REVISION
DRAWN	E.Reispere		01.08.2024	
APPV'D				

DESCRIPTION:

Spring swing SWAN

MATERIAL:

wood, metal, plastic

A4

WEIGHT:

SCALE: 1:50

SHEET 2 OF 18



Tiptiptap ⁰⁰

foundation

A

B

C

D

E

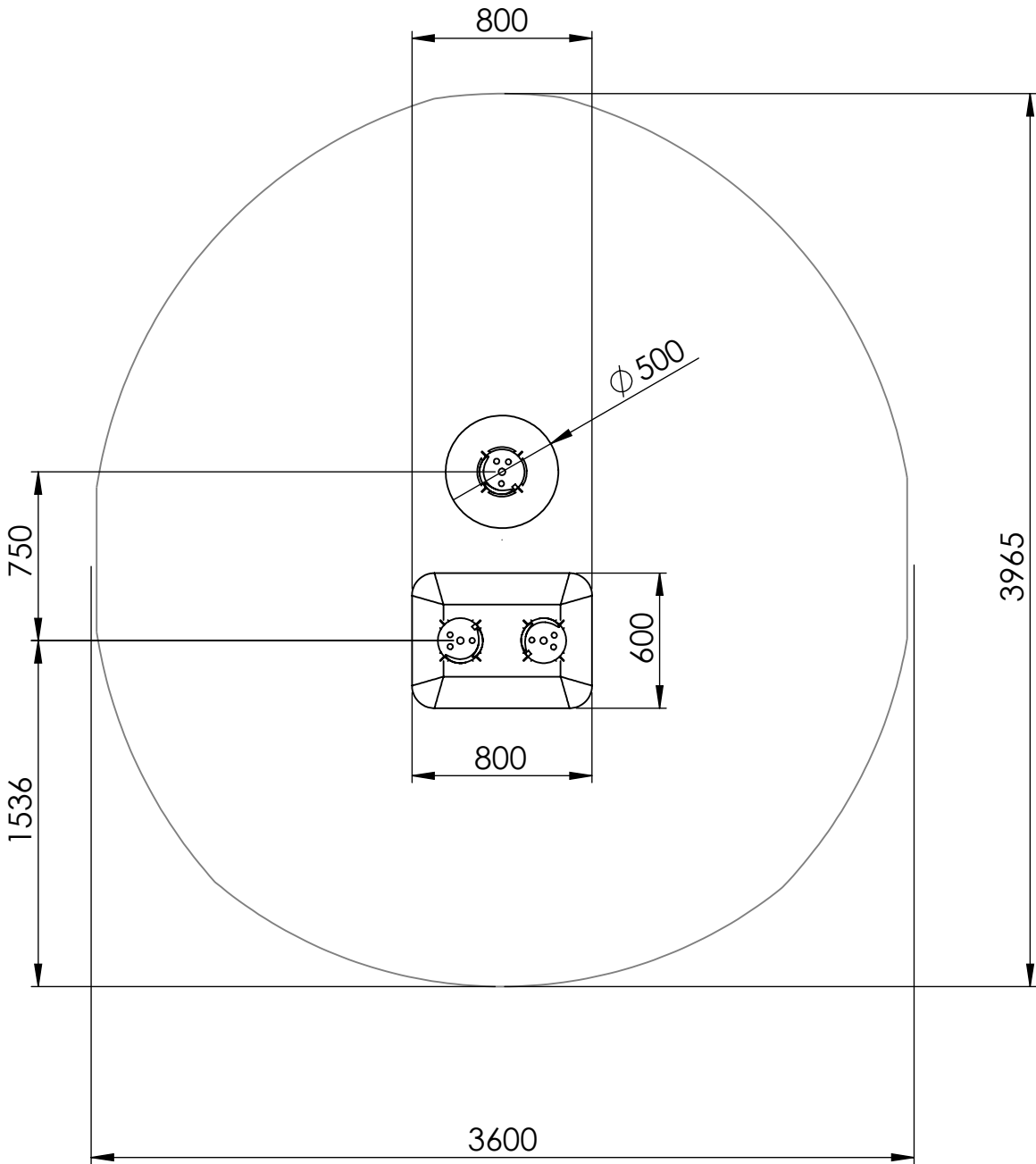

UNLESS OTHERWISE SPECIFIED:
 DIMENSIONS ARE IN MILLIMETERS
 WEIGHT ARE IN KILOGRAMM

PART NUMBER / DWG NO.:
VL53

	NAME	SIGNATURE	DATE	REVISION
DRAWN	E.Reispere		01.08.2024	
APPV'D				

DESCRIPTION:
Spring swing SWAN



MATERIAL:	wood, metal, plastic	A4
WEIGHT:		SCALE: 1:50
		SHEET 3 OF 18

dimensions

A

B

C

D

E

F

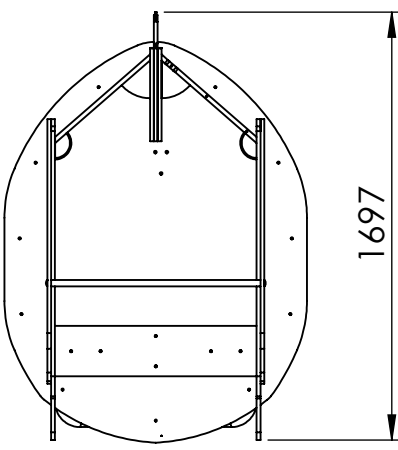
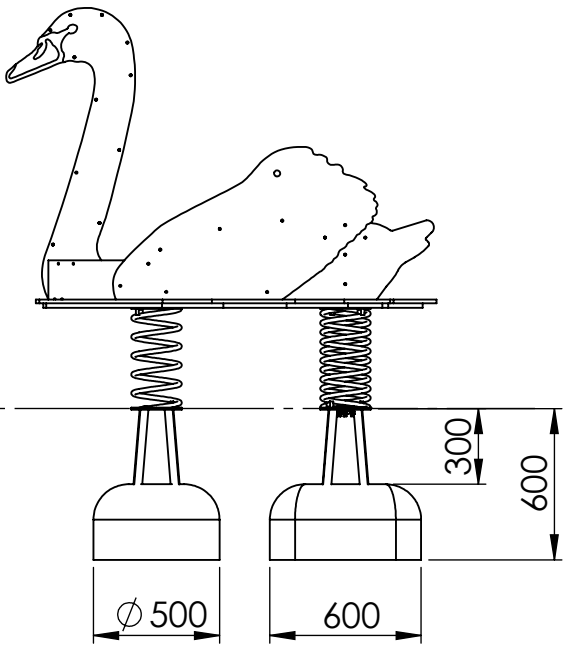
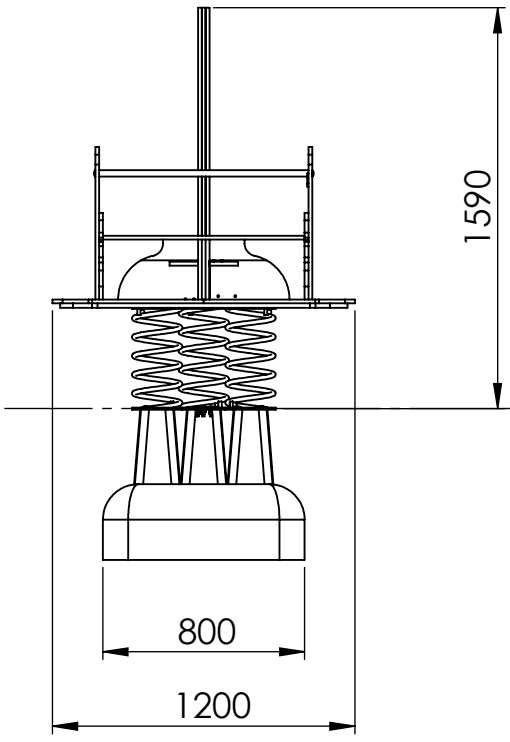

UNLESS OTHERWISE SPECIFIED:
 DIMENSIONS ARE IN MILLIMETERS
 WEIGHT ARE IN KILOGRAMM

PART NUMBER / DWG NO.:
VL53

	NAME	SIGNATURE	DATE	REVISION
DRAWN	E.Reispere		01.08.2024	
APPV'D				

DESCRIPTION:
Spring swing SWAN



MATERIAL:	wood, metal, plastic	A4
WEIGHT:	SCALE: 1:30	SHEET 4 OF 18

A

B

C

D

E

F

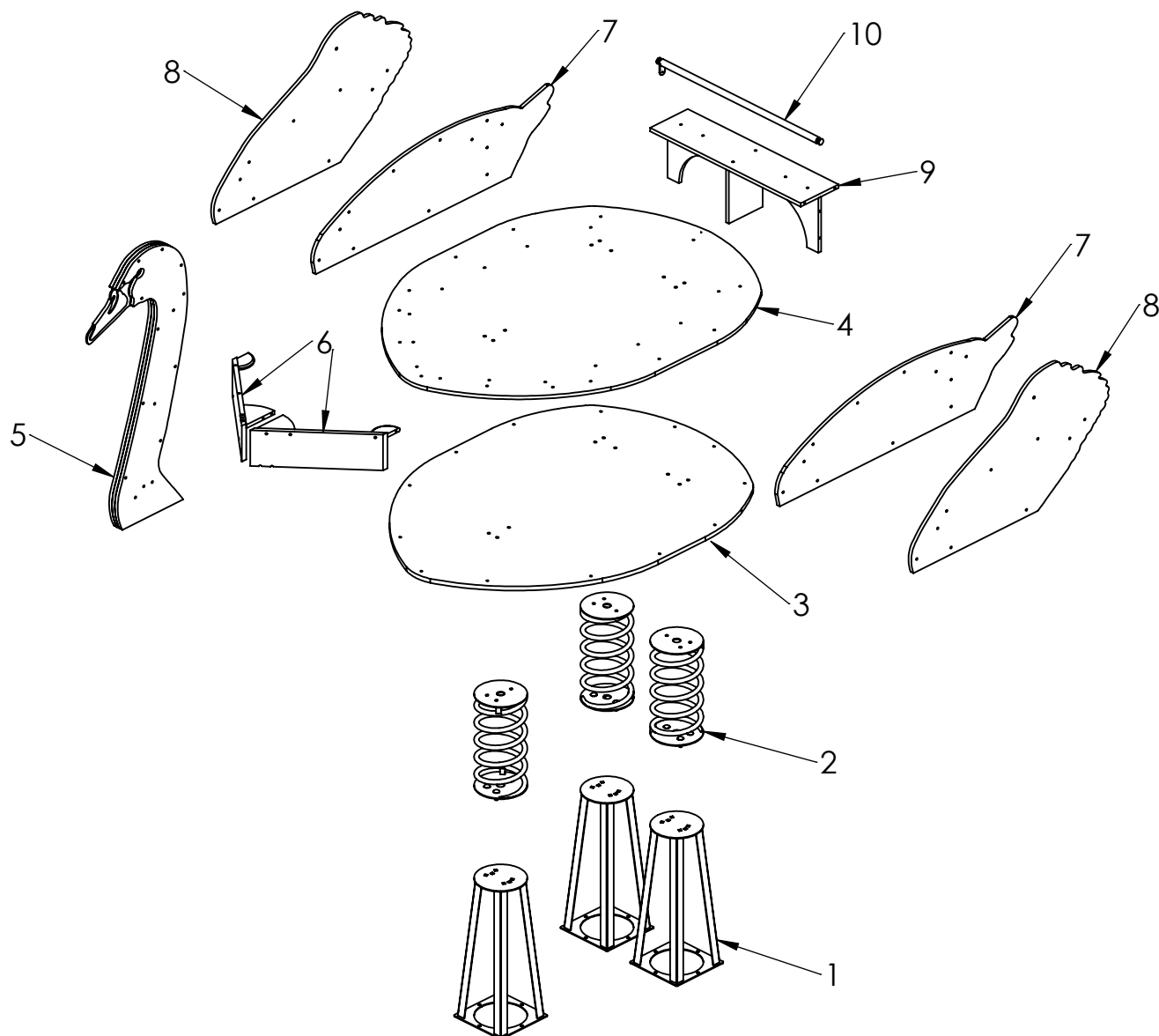

ITEM NO.	PART NUMBER
1	ground fixing
2	spring with spring disk
3	VL53 bottom support panel
4	VL53 bottom panel
5	VL53 head assembly 1
6	VL53 front support panel L
7	VL53 tail panel
8	VL53 side panel
9	VL53 seat panel
10	guardrail 830

UNLESS OTHERWISE SPECIFIED:
DIMENSIONS ARE IN MILLIMETERS
WEIGHT ARE IN KILOGRAMM

	NAME	SIGNATURE	DATE	REVISION
DRAWN	E.Reispere		01.08.2024	
APPV'D				

PART NUMBER / DWG NO.:

VL53

DESCRIPTION:

Spring swing SWAN

MATERIAL:

wood, metal, plastic

A4

WEIGHT:

SCALE: 1:25

SHEET 5 OF 18



Tiptap ⁰⁰

plast põhja alla versengid,
poldile M8 DIN7991

A

B

C

D

E

F

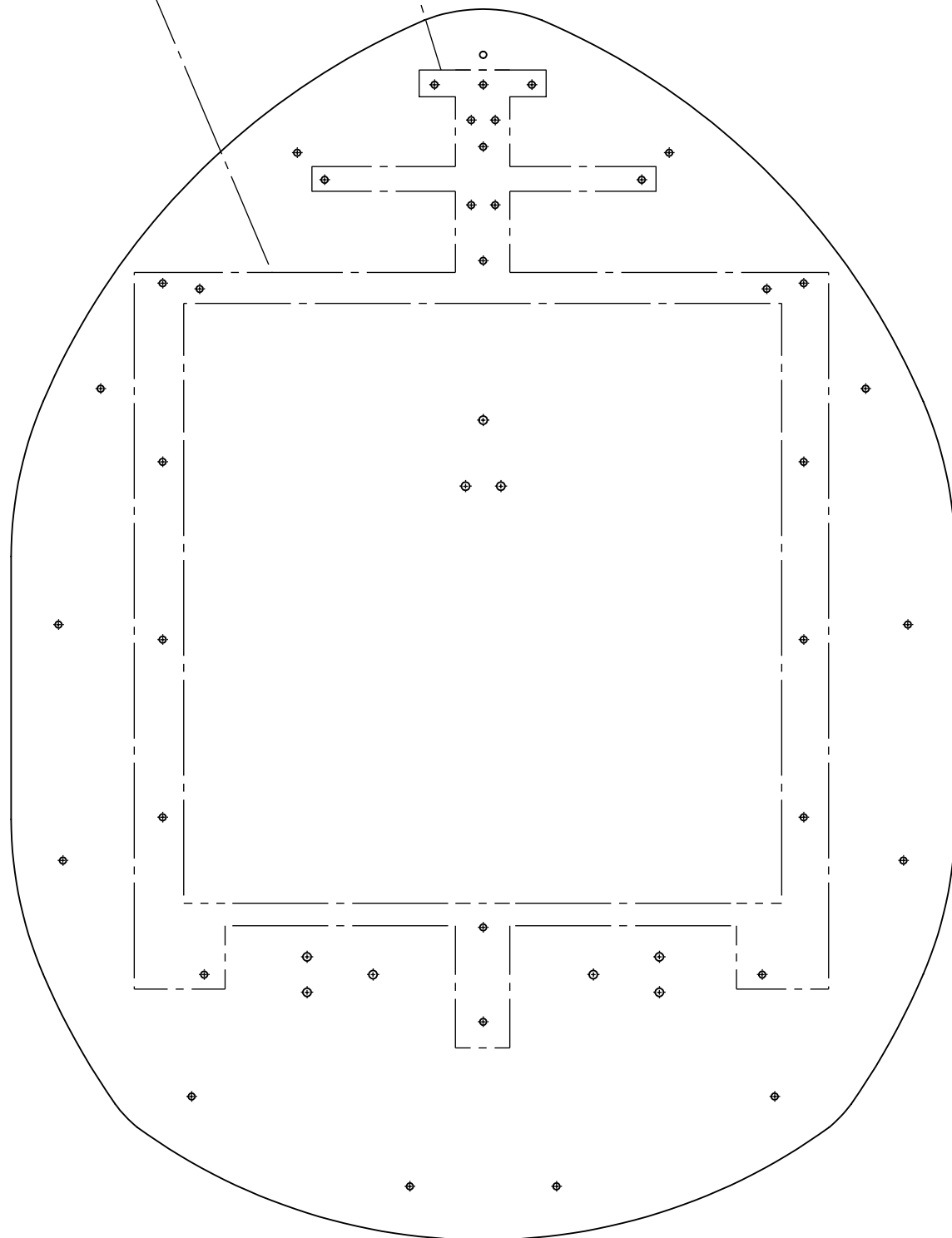

UNLESS OTHERWISE SPECIFIED:
DIMENSIONS ARE IN MILLIMETERS
WEIGHT ARE IN KILOGRAMM

PART NUMBER / DWG NO.:

VL53

	NAME	SIGNATURE	DATE	REVISION
DRAWN	E.Reispere		01.08.2024	
APPV'D				

DESCRIPTION:

Spring swing SWAN



Tiptiptap OÜ

MATERIAL:

wood, metal, plastic

A4

WEIGHT:

SCALE: 1:25

SHEET 6 OF 18

VL53 head support tube, add a bushing

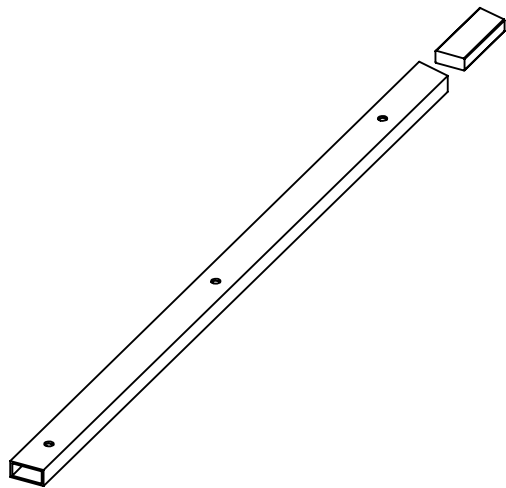
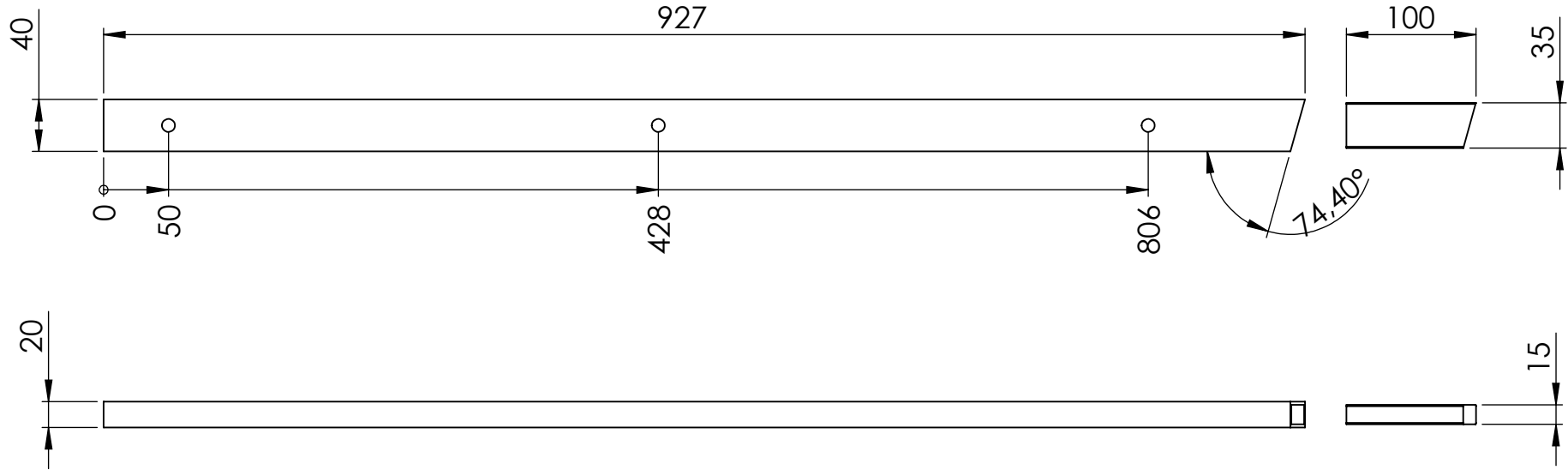

UNLESS OTHERWISE SPECIFIED:
DIMENSIONS ARE IN MILLIMETERS
WEIGHT ARE IN KILOGRAMM

	NAME	SIGNATURE	DATE	REVISION
DRAWN	E.Reispere		01.08.2024	
APPV'D				



PART NUMBER / DWG NO.: VL53

DESCRIPTION: Spring swing SWAN

MATERIAL: wood, metal, plastic

WEIGHT: SCALE: 1:20 SHEET 7 OF 18

A

B

C

D

E

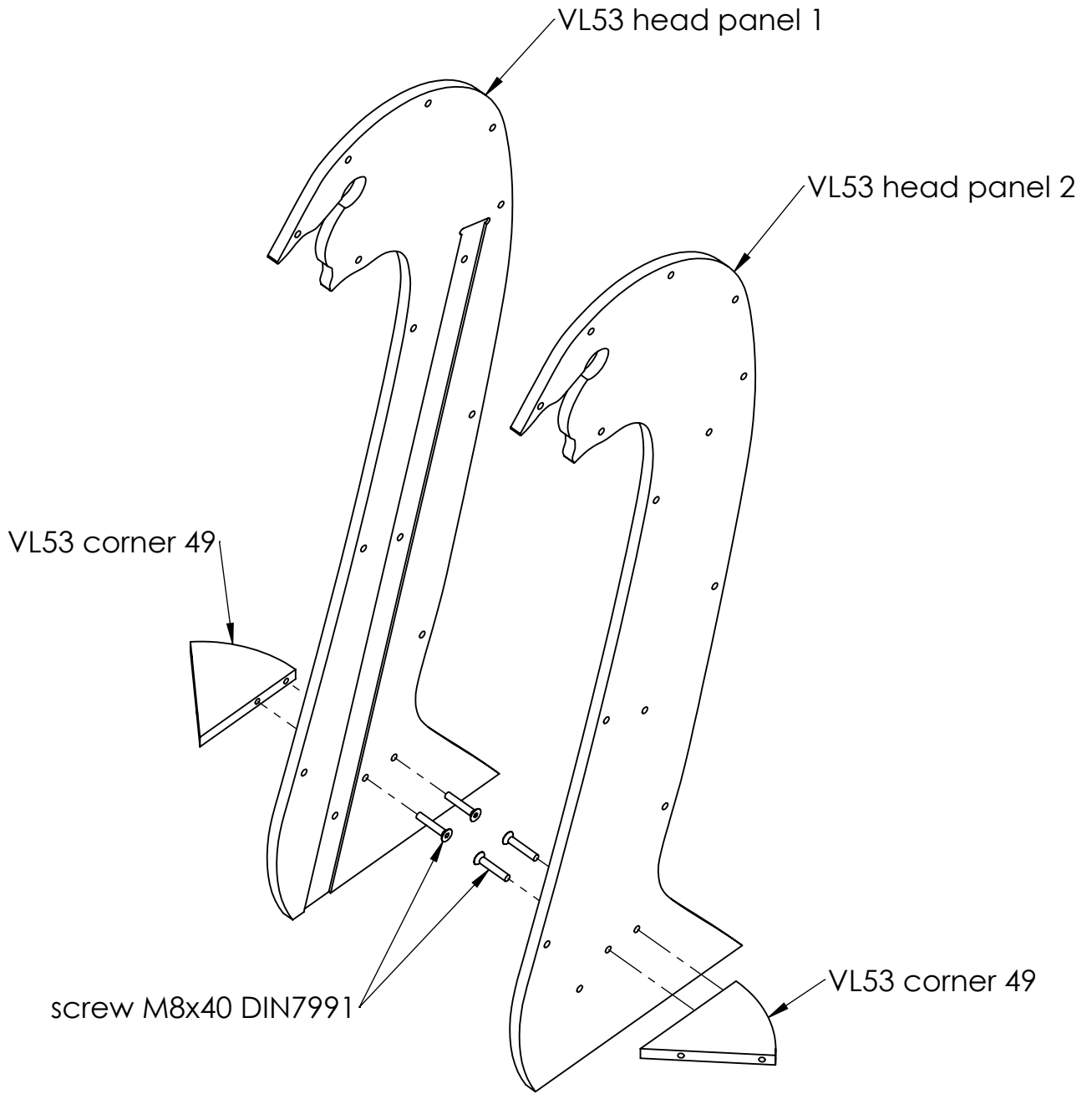

UNLESS OTHERWISE SPECIFIED:
 DIMENSIONS ARE IN MILLIMETERS
 WEIGHT ARE IN KILOGRAMM

PART NUMBER / DWG NO.:

VL53

	NAME	SIGNATURE	DATE	REVISION
DRAWN	E.Reispere		01.08.2024	
APPV'D				

DESCRIPTION:

Spring swing SWAN

F



Tiptap ⁰⁰

MATERIAL:

wood, metal, plastic

A4

WEIGHT:

SCALE: 1:25

SHEET 8 OF 18

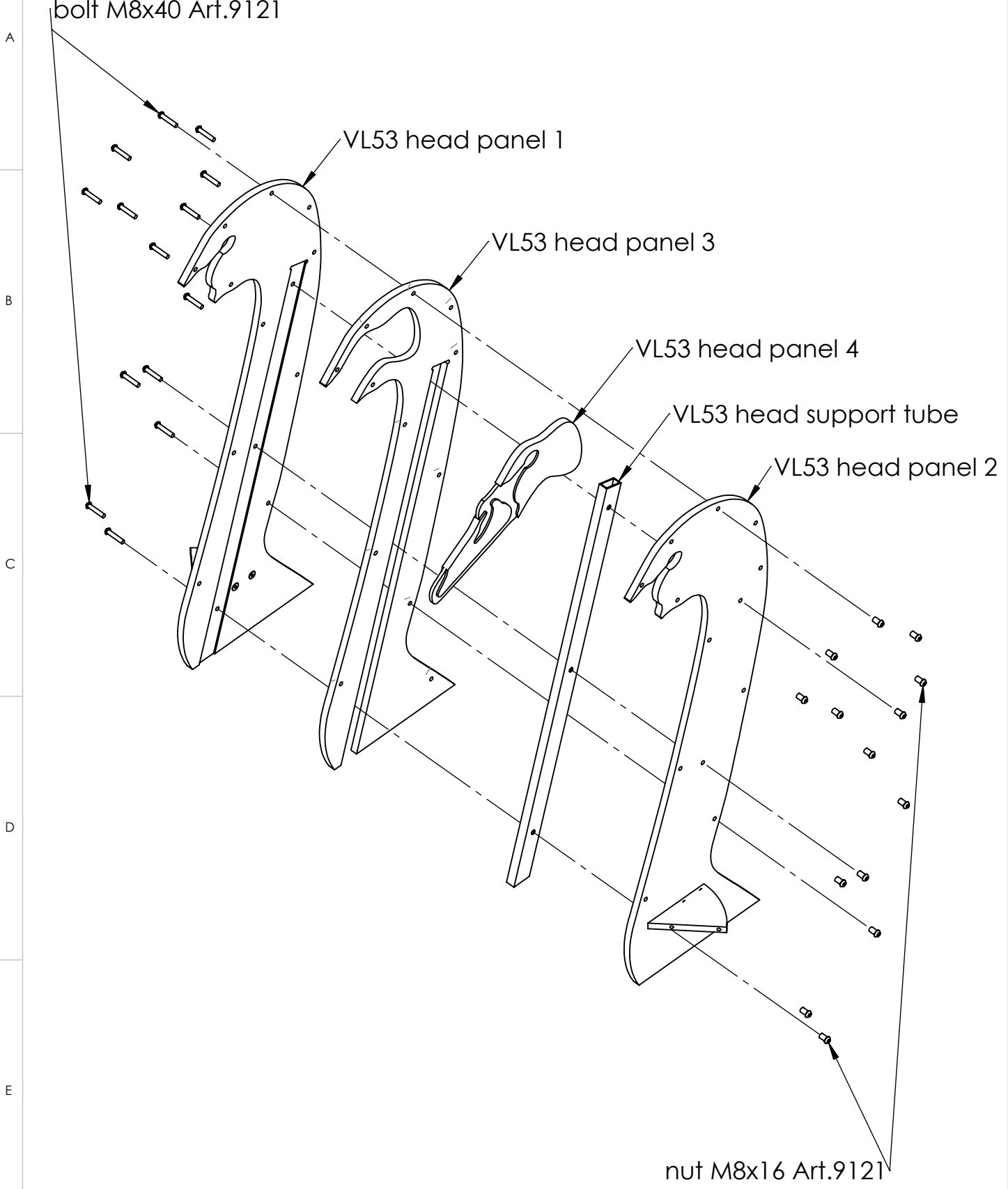

UNLESS OTHERWISE SPECIFIED:
 DIMENSIONS ARE IN MILLIMETERS
 WEIGHT ARE IN KILOGRAMM

PART NUMBER / DWG NO.:
VL53

	NAME	SIGNATURE	DATE	REVISION
DRAWN	E.Reispere		01.08.2024	
APPV'D				

DESCRIPTION:
Spring swing SWAN



MATERIAL:	wood, metal, plastic	A4
WEIGHT:	SCALE: 1:25	SHEET 9 OF 18

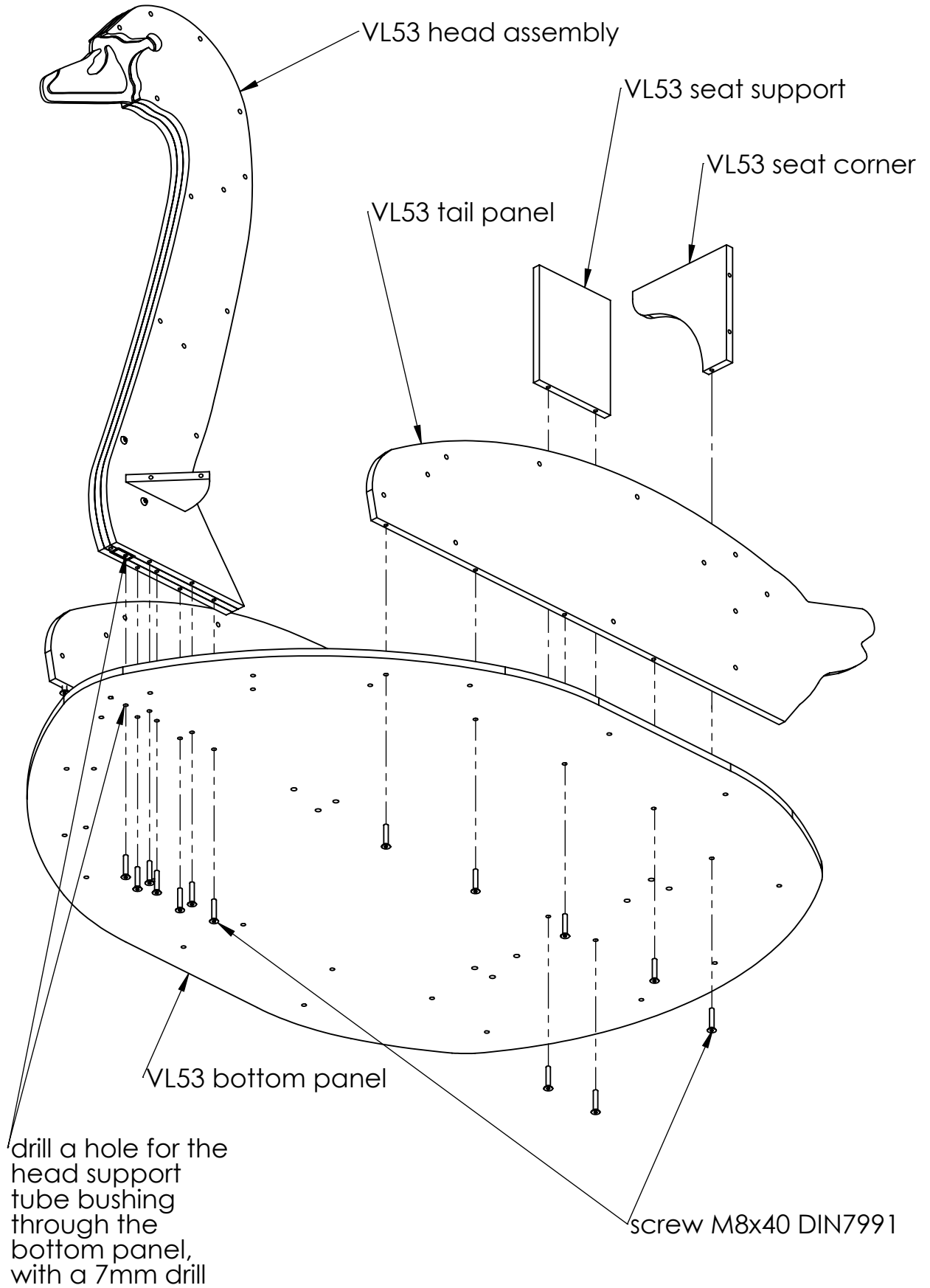

UNLESS OTHERWISE SPECIFIED:
DIMENSIONS ARE IN MILLIMETERS
WEIGHT ARE IN KILOGRAMM

PART NUMBER / DWG NO.:

VL53

	NAME	SIGNATURE	DATE	REVISION
DRAWN	E.Reispere		01.08.2024	
APPV'D				

DESCRIPTION:

Spring swing SWAN



Tiptiptap OÜ

MATERIAL:

wood, metal, plastic

A4

WEIGHT:

SCALE: 1:25

SHEET 10 OF 18

VL53 front support panels

A

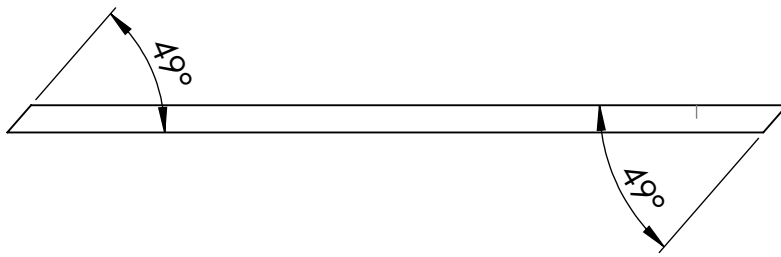

B

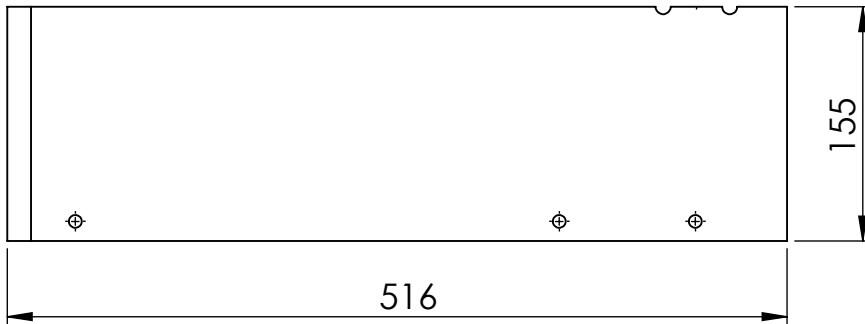

C

D

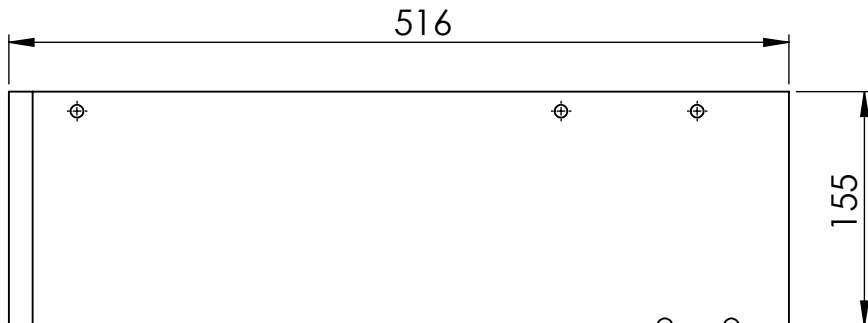

E

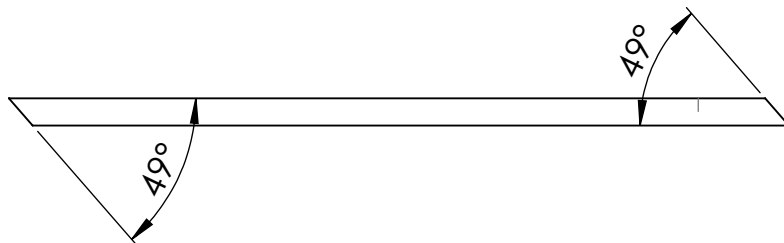

UNLESS OTHERWISE SPECIFIED:
 DIMENSIONS ARE IN MILLIMETERS
 WEIGHT ARE IN KILOGRAMM

PART NUMBER / DWG NO.:

VL53

	NAME	SIGNATURE	DATE	REVISION
DRAWN	E.Reispere		01.08.2024	
APPV'D				

DESCRIPTION:

Spring swing SWAN

F



Tiptiptap OÜ

MATERIAL:

wood, metal, plastic

A4

WEIGHT:

SCALE: 1:5

SHEET 11 OF 18

A

B

C

D

E

F

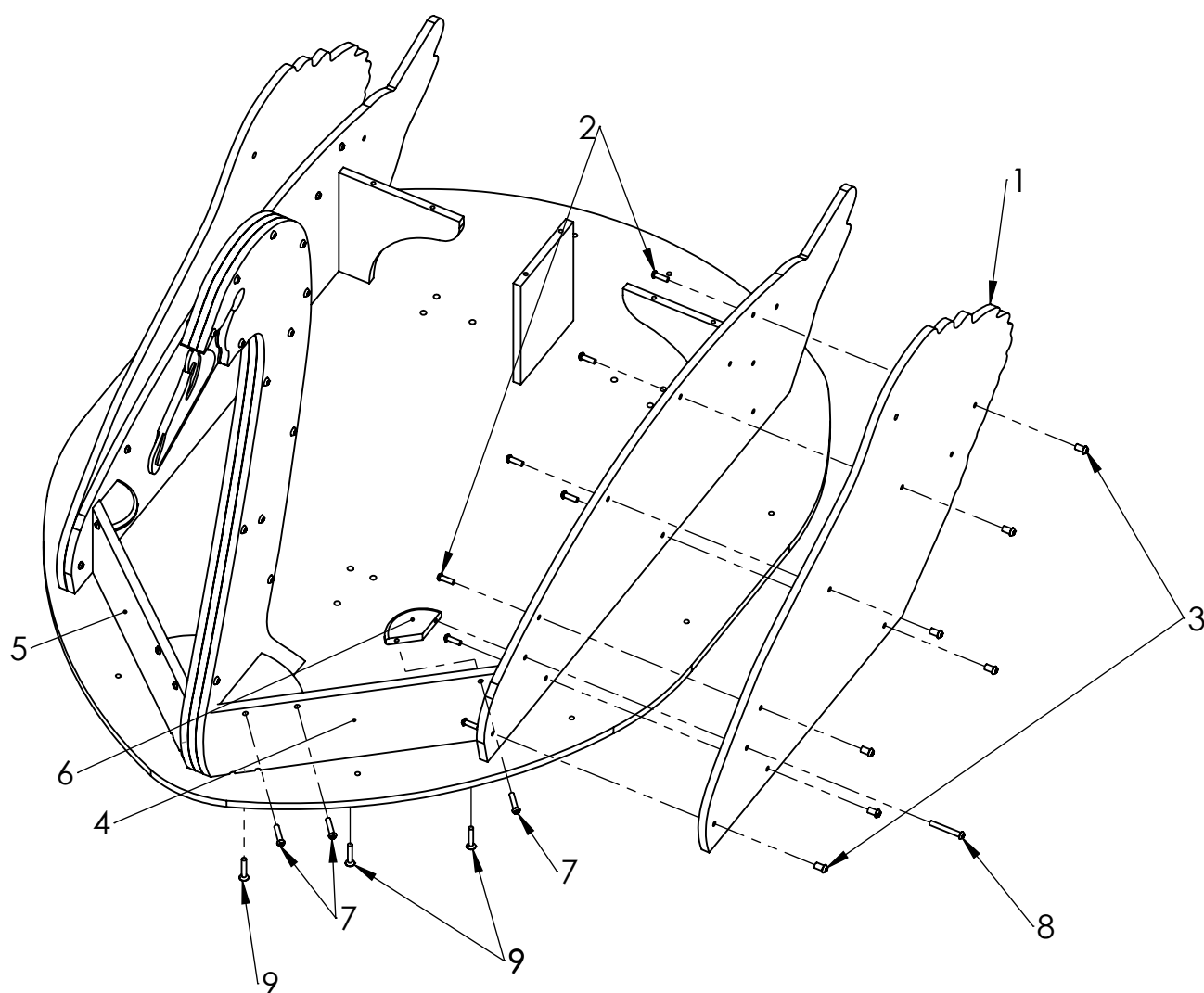

ITEM NO.	PART NUMBER
1	VL53 side panel
2	bolt M8x25 Art.9121
3	nut M18x16 Art. 9121
4	VL53 front support panel L
5	VL53 front support panel R
6	VL53 corner 131
7	bolt M8x40 Art.9121
8	bolt M8x60 Art.9121
9	screw M8x40 DIN7991

UNLESS OTHERWISE SPECIFIED:
DIMENSIONS ARE IN MILLIMETERS
WEIGHT ARE IN KILOGRAMM

PART NUMBER / DWG NO.:

VL53

	NAME	SIGNATURE	DATE	REVISION
DRAWN	E.Reispere		01.08.2024	
APPV'D				

DESCRIPTION:

Spring swing SWAN

Tiptiptap^{OO}

MATERIAL:

wood, metal, plastic

A4

WEIGHT:

SCALE: 1:5

SHEET 12 OF 18

A

B

C

D

E

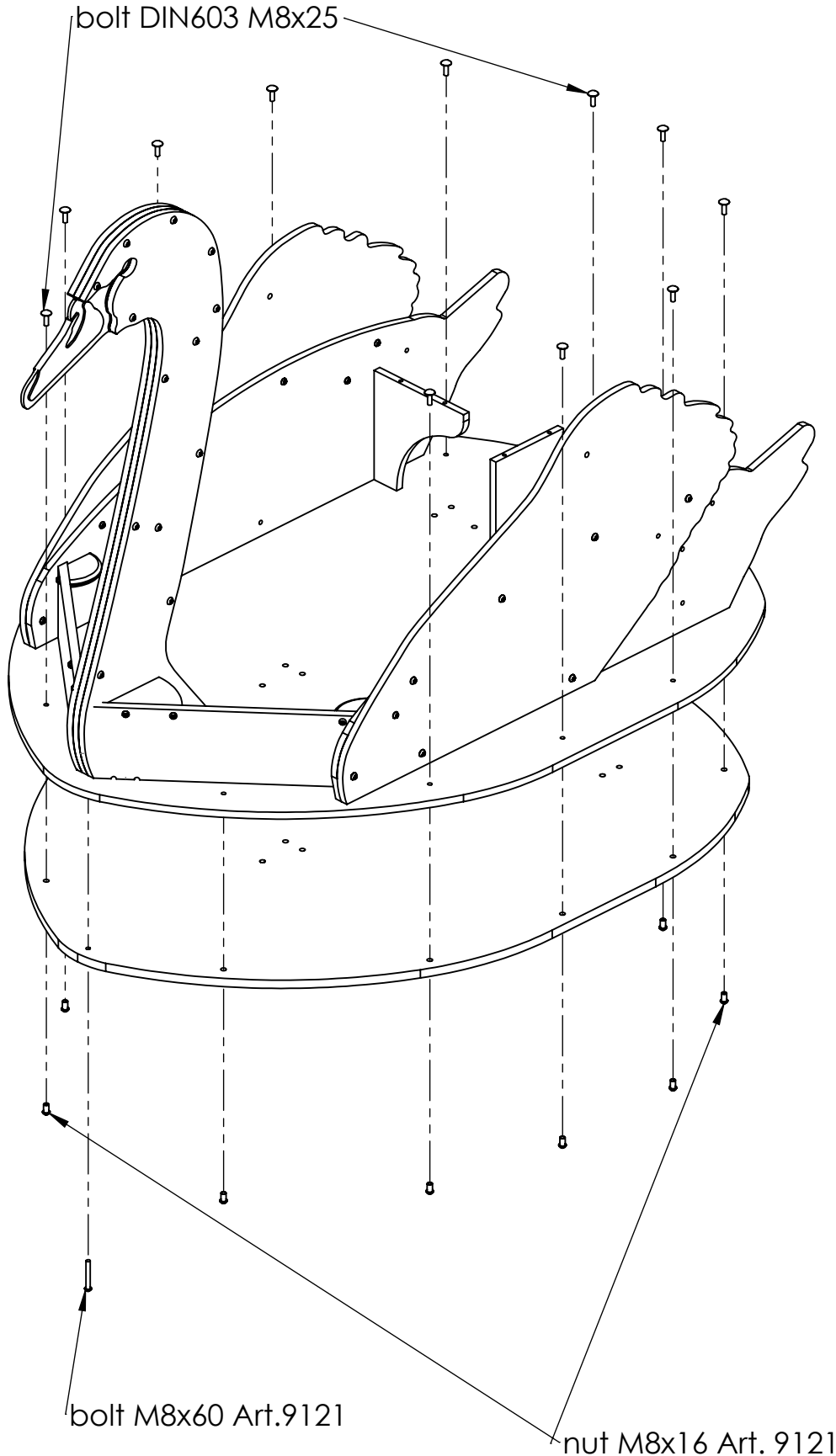

UNLESS OTHERWISE SPECIFIED:
 DIMENSIONS ARE IN MILLIMETERS
 WEIGHT ARE IN KILOGRAMM

PART NUMBER / DWG NO.:
VL53

	NAME	SIGNATURE	DATE	REVISION
DRAWN	E.Reispere		01.08.2024	
APPV'D				

DESCRIPTION:
Spring swing SWAN



MATERIAL:	wood, metal, plastic	A4
WEIGHT:		SCALE: 1:25
		SHEET 13 OF 18

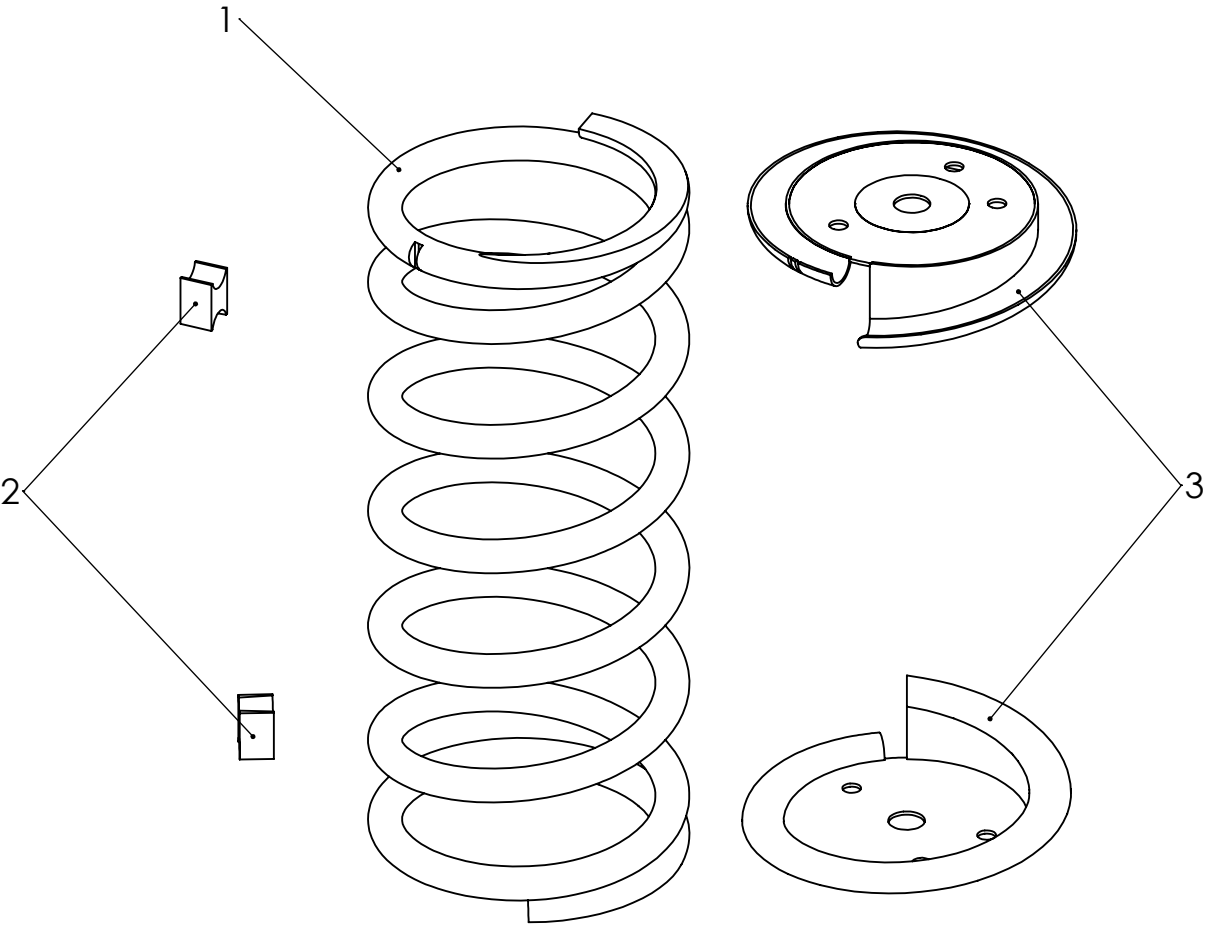

ITEM NO.	PART NUMBER	DESCRIPTION	QTY.
1	spring	painted steel	1
2	distance block	HP plastic	2
3	spring plate	painted steel	2

UNLESS OTHERWISE SPECIFIED:
DIMENSIONS ARE IN MILLIMETERS
WEIGHT ARE IN KILOGRAMM

PART NUMBER / DWG NO.:

VL53

	NAME	SIGNATURE	DATE	REVISION
DRAWN	E.Reispere		01.08.2024	
APPV'D				

DESCRIPTION:

Spring swing SWAN

MATERIAL:

wood, metal, plastic

A4

WEIGHT:

SCALE: 1:4

SHEET 14 OF 18



Tiptiptap ^{OO}

A

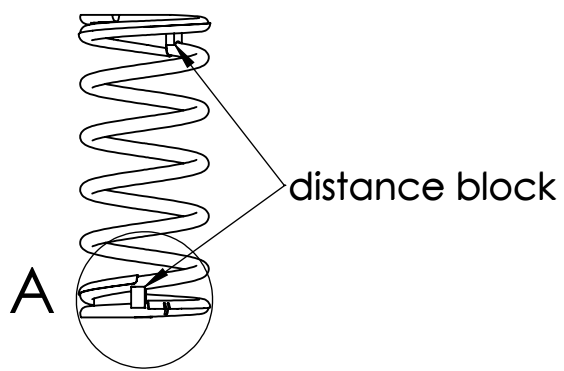

view 1

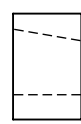
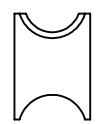
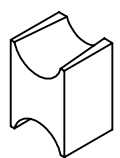

view 2



B

View A

C

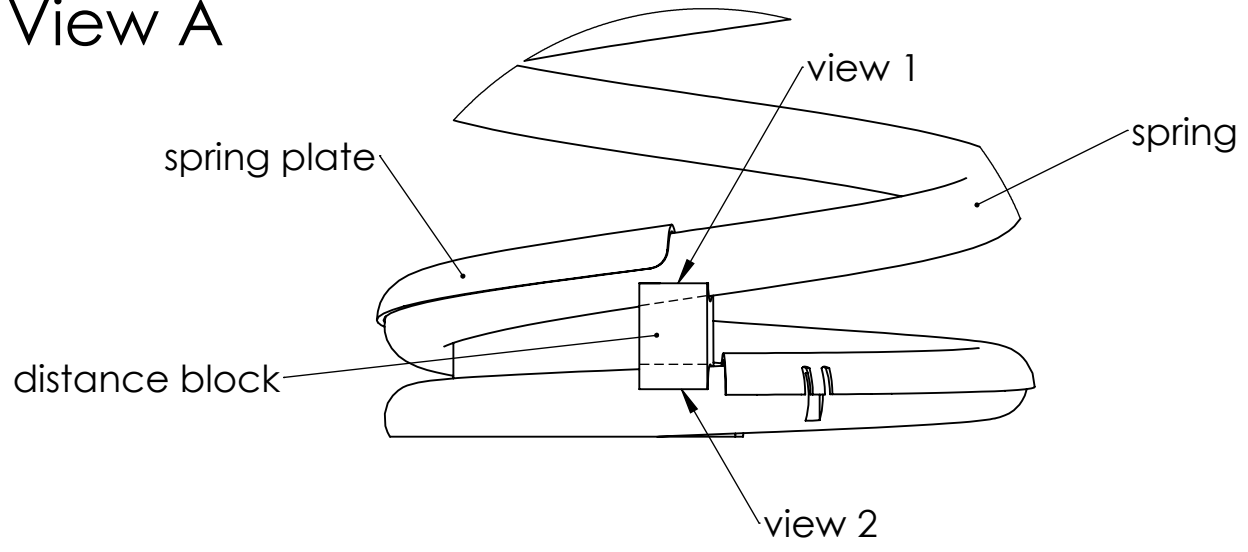

D

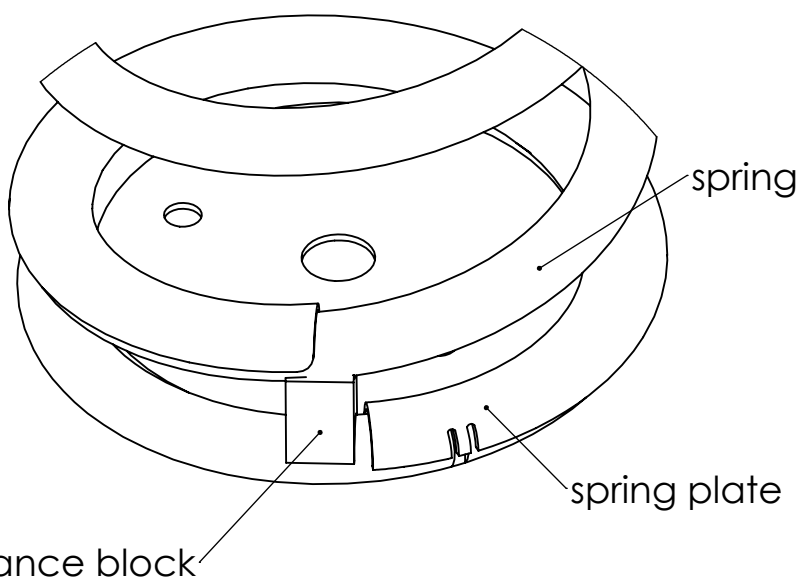

E

F

UNLESS OTHERWISE SPECIFIED: DIMENSIONS ARE IN MILLIMETERS WEIGHT ARE IN KILOGRAMM				
	NAME	SIGNATURE	DATE	REVISION
DRAWN	E.Reispere		01.08.2024	
APPV'D				

PART NUMBER / DWG NO.:	VL53
DESCRIPTION:	Spring swing SWAN



MATERIAL:	wood, metal, plastic	A4
WEIGHT:	SCALE: 1:4	SHEET 15 OF 18

A

B

C

D

E

F

guardrail 830
bolt M10x60 Art.9121

screw M8x40 DIN7991

VL53 seat panel

wood screw 4,8x13

bolt M10x60 Art.9121

bolt DIN603 M10x60
nut cover M12
washer M10 DIN9054
nut DIN985 M10
nut cover cap M12

UNLESS OTHERWISE SPECIFIED:
DIMENSIONS ARE IN MILLIMETERS
WEIGHT ARE IN KILOGRAMM

PART NUMBER / DWG NO.:

VL53

	NAME	SIGNATURE	DATE	REVISION
DRAWN	E.Reispere		01.08.2024	
APPV'D				

DESCRIPTION:

Spring swing SWAN



Tiptap OÜ

MATERIAL:

wood, metal, plastic

A4

WEIGHT:

SCALE: 1:25

SHEET 16 OF 18

A

B

C

D

E

F

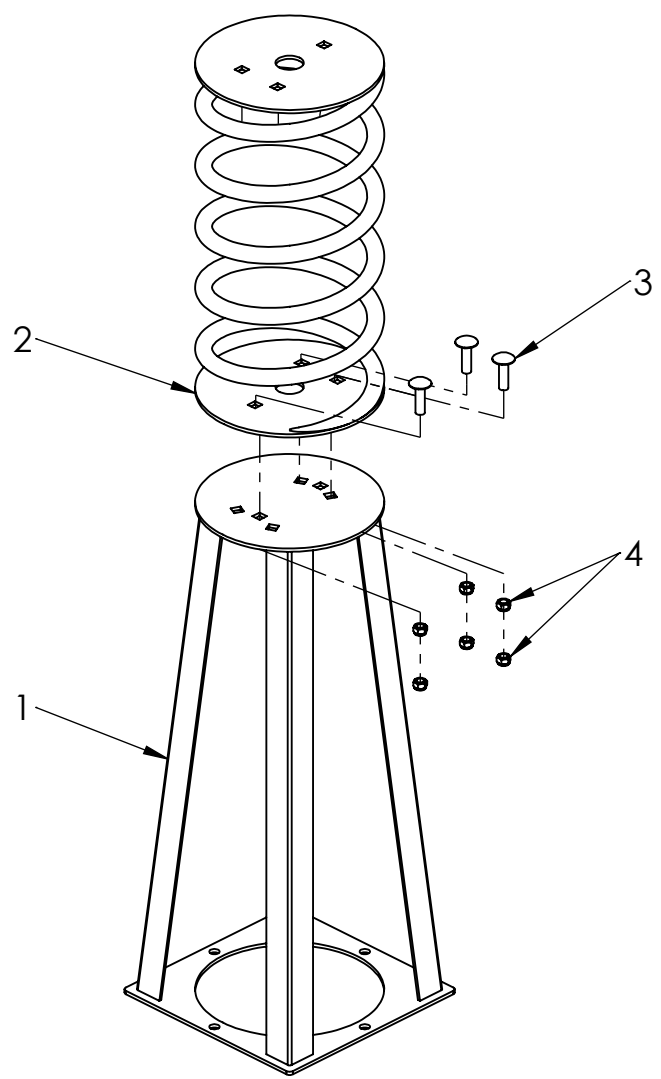

ITEM NO.	PART NUMBER
1	ground fixing
2	spring with spring disk
3	bolt DIN603 M10x35
4	nut DIN985 M10

UNLESS OTHERWISE SPECIFIED: DIMENSIONS ARE IN MILLIMETERS WEIGHT ARE IN KILOGRAMM				
	NAME	SIGNATURE	DATE	REVISION
DRAWN	E.Reispere		01.08.2024	
APPV'D				

PART NUMBER / DWG NO.:	VL53
DESCRIPTION:	Spring swing SWAN



MATERIAL:	wood, metal, plastic	A4
WEIGHT:		SCALE: 1:10
		SHEET 17 OF 18

A

B

C

D

E

F

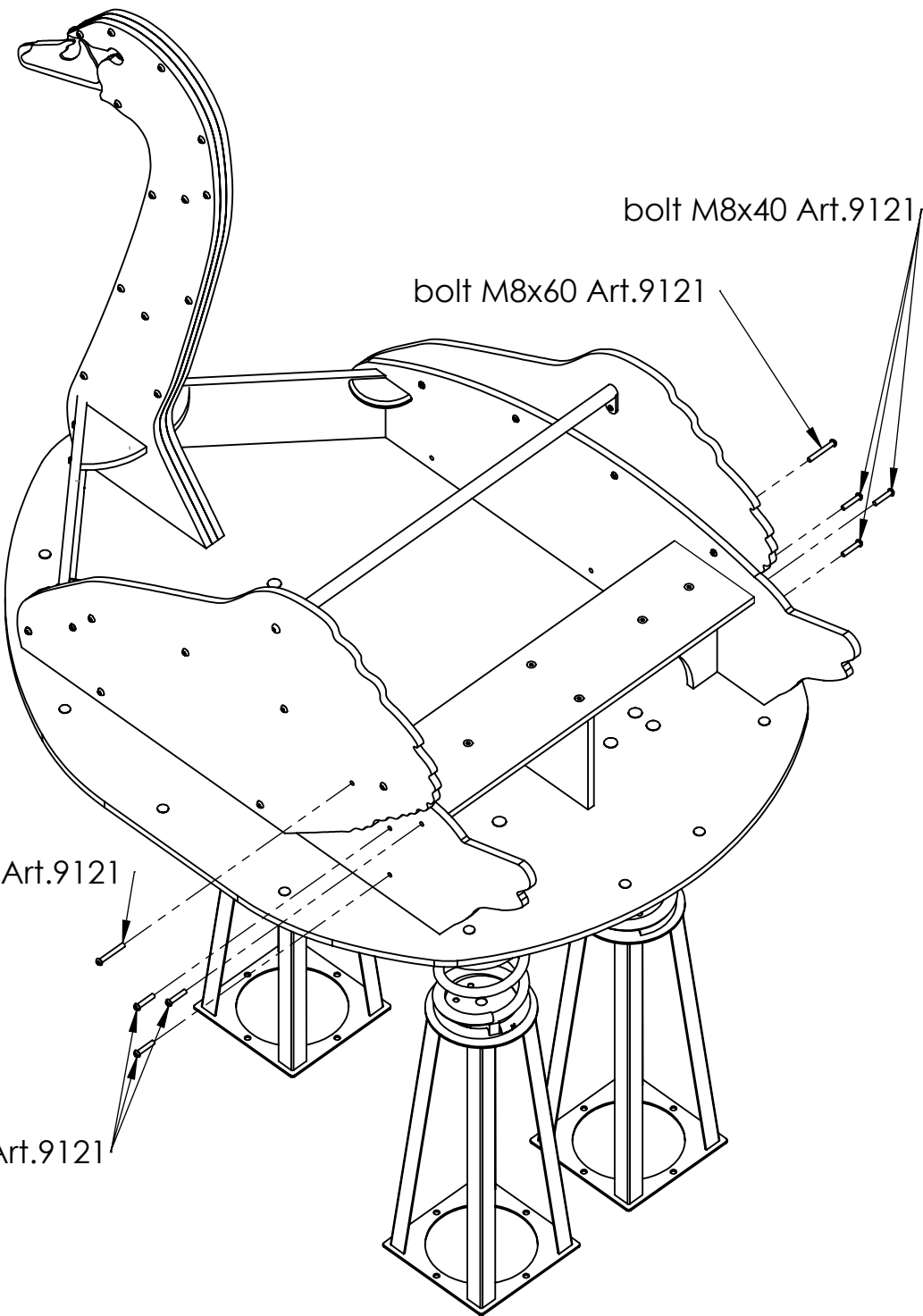

bolt M8x40 Art.9121

bolt M8x60 Art.9121

bolt M8x60 Art.9121

bolt M8x40 Art.9121

UNLESS OTHERWISE SPECIFIED:
 DIMENSIONS ARE IN MILLIMETERS
 WEIGHT ARE IN KILOGRAMM

PART NUMBER / DWG NO.:
VL53

	NAME	SIGNATURE	DATE	REVISION
DRAWN	E.Reispere		01.08.2024	
APPV'D				

DESCRIPTION:
Spring swing SWAN



MATERIAL: wood, metal, plastic

A4

WEIGHT: SCALE: 1:25 SHEET 18 OF 18